

ABOV SEMICONDUCTOR
8-BIT SINGLE-CHIP MICROCONTROLLERS

MC81F4x16

MC81F4216 D/B/U
MC81F4316 S/M/G/D/K/U
MC81F4416 K/Q

User's Manual (Ver. 1.42)



Version 1.42
Published by FAE Team
©2008 ~ ABOV Semiconductor Co., Ltd. All rights reserved.

Additional information of this manual may be served by ABOV Semiconductor offices in Korea or Distributors.

ABOV Semiconductor reserves the right to make changes to any information here in at any time without notice.

The information, diagrams and other data in this manual are correct and reliable; however, ABOV Semiconductor is in no way responsible for any violations of patents or other rights of the third party generated by the use of this manual.

REVISION HISTORY

VERSION 1.42 (April 24, 2012) This book

Add the chapter ' 7.10 POR Electrical CHARACTERISTICS'.

VERSION 1.41 (November 28, 2011) This book

Update 28SOP package diagram.

VERSION 1.40 (February 9, 2011) This book

Update 24QFN pin assignment and package diagram.

VERSION 1.39 (December 28, 2010) This book

Change '5.5v' to "VDD level" in DC Electrical Characteristics description(page 40/41).

Change '5.0v' to "External RC Condition" in DC Electrical Characteristics description(page 48).

Change '5.0v' to "Internal RC Condition" in DC Electrical Characteristics description(page 49).

VERSION 1.38 (September 9, 2010) This book

Update 28QFN pin assignment and package diagram.

VERSION 1.37 (December 23, 2009) This book

Update the chapter ' 26.3 Reset circuit'.

Add Reset pin information

VERSION 1.36 (December 15, 2009) This book

Update the chapter ' 26.3 Reset circuit'.

VERSION 1.35 (October 19, 2009) This book

Add a note about SCK port at R0CONM register description.

Change EVA.board picture. (the board's color is changed from blue to green)

VERSION 1.34 (September 30, 2009)

Correct the duty equation of PMW0/1.

Add more tools at "1.3 Development Tools".

VERSION 1.33 (September 18, 2009)

Add more descriptions at PWM function descriptions.

VERSION 1.32 (September 4, 2009)

Remove '1.83v' at "Feature"

VERSION 1.31 (August 24, 2009)

Update the "Typical Characteristics".

VERSION 1.3 (August 21, 2009)

Remove rising/falling time at LVR electrical characteristics.

Change '1.83v' to "POR level" in POR description.

The package diagram of 44 MQFP is fixed.

Add POR level at "DC CHARACTERISTICS".

Add ROM option read timing information.

Add "Typical Characteristics".

VERSION 1.22 (July 7, 2009)

"Figure 25-5 IIC Salve Receiving Timing Diagram" is modified.

"29.3 Hardware Conditions to Enter the ISP Mode" is updated.

Notes of R35 port control registers are updated.

VERSION 1.21 (June 29, 2009)

Add 'Watch Timer' at stop release source at "Peripheral Operation During Power Saving Mode" table in "Sleep vs Stop" chapter.

VERSION 1.2 (June 26, 2009)

Change the representative name from 'MC81F4416' to 'MC81F4x16'.

Remove 'WDT' at "Stop release" description. 'WDT' is not a release source of STOP mode.

Change "fxin" to "fbuz" at buzzer frequency calculation in "BUZZER" chapter

VERSION 1.1 (June 17, 2009)

Add rom writing endurance at features.

VERSION 1.0 (June 15, 2009)

Remove "preliminary".

Some errata are fixed. (I2C -> IIC, IICSDR->IICSCR)

Remove "R57, R56, R55, R54" in R5 port data register table.

Add "Buzzer frequency table".

VERSION 0.92 Preliminary (May 26, 2009)

Pin number errata is fixed on 20 PDIP/SOP PIN ASSIGNMENT diagram.

VERSION 0.91 Preliminary (April 28, 2009)

'4216S' is changed to '4316' for 24 SSOP at 'PIN ASSIGNMENT'.

Delete a note1 at '22.5 recommended circuit'

VERSION 0.9 Preliminary (April 16, 2009)

Fix the erratum at 'Ordering Information'. '4216S' is changed to '4316' for 24 SSOP.

Add a sub-chapter 'Changing the stabilizing time' at the chapter 'Power down operation'.

Add a note for R33/R34 ports after R3CONH description.

One of BIT's clock source '2048' is changed to '1024'.

VERSION 0.8 Preliminary (April 8, 2009)

Description of SIO procedure is updated.

Description of ISP chapter is updated.

Note for 20 pin package is added at pin assignment and power down mode.

VERSION 0.7 Preliminary (April 1, 2009)

Chapter '7.ELECTRICAL CHARACTERISTICS' is updated.

VERSION 0.6 Preliminary (March 19, 2009)

The SCLK pin for ISP is moved to R11 port.

Add 24/20 pin devices information.

VERSION 0.5 Preliminary (March 5, 2009)

The SCLK pin for ISP is moved to R14 port.

Note for ADC recommended circuit is changed.

Change 44MQFP package diagram.

VERSION 0.4 Preliminary (February 12, 2009)

Update the chapter '6. PORT STRUCTURE'.

Update the chapter '7. ELECTRICAL CHARACTERISTICS'.

Update the chapter '9. IN SYSTEM PROGRAMMING'.

VERSION 0.3 Preliminary (December 19, 2008)

Block diagrams of Timer 2/3 and PWM are corrected.

VERSION 0.2 Preliminary (November 17, 2008)

Some errata are corrected.

VERSION 0.1 Preliminary (November 10, 2008)

Change some bit and symbol names about interrupts.

VERSION 0.0 Preliminary (October 31, 2008)

TABLE OF CONTENTS

REVISION HISTORY	3
TABLE OF CONTENTS	6
1. OVERVIEW	10
1.1 Description	10
1.2 Features	10
1.3 Development Tools	12
1.4 Ordering Information	13
2. BLOCK DIAGRAM	14
3. PIN ASSIGNMENT	15
3.1 44 MQFP	15
3.2 42 SDIP	16
3.3 32 SDIP/SOP	16
3.4 28 SKDIP/SOP	17
3.5 28 QFN	17
3.6 24 SSOP	18
3.7 24 QFN	18
3.8 20 PDIP/SOP	19
3.9 Summary	20
4. PACKAGE DIAGRAM	22
4.1 44 MQFP - MC81F4416Q	22
4.2 42 SDIP - MC81F4416K	22
4.3 32 SDIP - MC81F4316K	23
4.4 32 SOP - MC81F4316D	23
4.5 28 SKDIP - MC81F4316G	24
4.6 28 SOP - MC81F4316M	25
4.7 28 QFN - MC81F4316U	29
4.8 24 SSOP - MC81F4316S	31
4.9 24 QFN - MC81F4216U	32
4.10 20 PDIP - MC81F4216B	33
4.11 20 SOP - MC81F4216D	33
5. PIN DESCRIPTION	34
6. PORT STRUCTURE	38
7. ELECTRICAL CHARACTERISTICS	42
7.1 Absolute Maximum Ratings	42
7.2 RECOMMENDED OPERATING CONDITION	42
7.3 A/D CONVERTER CHARACTERISTICS	43
7.4 DC CHARACTERISTICS	44
7.5 DC CHARACTERISTICS(continued)	45
7.6 Input/output Capacitance	45
7.7 Serial I/O Characteristics	46
7.8 Data Retention Voltage in Stop Mode	47
7.9 LVR (Low Voltage Reset) Electrical Characteristics	49
7.10 POR (Power on Reset) Electrical Characteristics	49
7.11 UART Timing Characteristics	49
7.12 IIC Timing Characteristics	51

7.13 Main clock Oscillator Characteristics	52
7.14 External RC Oscillation Characteristics	52
7.15 Internal RC Oscillation Characteristics	53
7.16 Sub clock Oscillator Characteristics	53
7.17 Main Oscillation Stabilization Time	53
7.18 Sub Oscillation Stabilization Time	54
7.19 Operating Voltage Range	55
7.20 Typical Characteristics	56
8. ROM OPTION	61
8.1 Rom Option	61
8.2 Read Timing	62
9. MEMORY ORGANIZATION	63
9.1 Registers	63
9.2 Program Memory	66
9.3 Data Memory	70
9.4 User Memory	70
9.5 Stack Area	70
9.6 Control Registers (SFR)	71
9.7 Addressing modes	76
10. I/O PORTS	83
10.1 R0 Port Registers	85
10.2 R1 Port Registers	90
10.3 R2 Port Registers	94
10.4 R3 Port Registers	97
10.5 R4 Port Registers	99
10.6 R5 Port	101
11. INTERRUPT CONTROLLER	102
11.1 Registers	103
11.2 Interrupt Sequence	108
11.3 BRK Interrupt	110
11.4 Shared Interrupt Vector	110
11.5 Multi Interrupt	111
11.6 Interrupt Vector & Priority Table	112
12. EXTERNAL INTERRUPTS	113
12.1 Registers	113
12.2 Procedure	116
13. CLOCK GENERATOR	117
13.1 Registers	118
14. OSCILLATION CIRCUITS	119
14.1 Main Oscillation Circuits	119
14.2 Sub Oscillation Circuits	120
14.3 PCB Layout	121
15. BASIC INTERVAL TIMER	122
15.1 Registers	123
16. WATCH DOG TIMER	125
16.1 Registers	126
17. WATCH TIMER	127
17.1 Registers	128

18. Timer 0/1	129
18.1 Registers.....	129
18.2 Timer 0 8-Bit Mode	133
18.3 Timer 1 8-Bit Mode	135
18.4 Timer 0 16-BIT Mode.....	137
19. Timer 2/3.....	141
19.1 Registers.....	141
19.2 Timer 2 8-Bit Mode	145
19.3 Timer 3 8-Bit Mode	147
19.4 Timer 2 16-Bit Mode	149
20. High Speed PWM.....	152
20.1 Registers.....	154
21. BUZZER.....	156
21.1 Registers.....	157
21.2 Frequency table	158
22. 12-BIT ADC.....	159
22.1 Registers.....	160
22.2 Procedure	161
22.3 Conversion Timing.....	161
22.4 Internal Reference Voltage.....	162
22.5 Recommended Circuit	162
23. SERIAL I/O INTERFACE	163
23.1 Registers.....	164
23.2 Procedure	165
24. UART.....	166
24.1 Registers.....	167
24.2 Modes and Procedures.....	169
24.3 Baud rate calculations	174
24.4 Multi-processor Communication	175
24.5 Interrupt.....	176
25. SLAVE IIC	177
25.1 Roles.....	177
25.2 Registers.....	177
25.3 Message format.....	180
25.4 Procedure	182
26. RESET	184
26.1 Reset Process	184
26.2 Reset Sources	185
26.3 Reset circuit.....	185
26.4 Watch Dog Timer Reset	186
26.5 Power On Reset	187
26.6 Low Voltage Reset.....	187
27. POWER DOWN OPERATION.....	188
27.1 Sleep Mode.....	188
27.2 Stop Mode.....	190
27.3 Sleep vs Stop.....	193
27.4 Changing the stabilizing time.....	194
27.5 Minimizing Current Consumption	194

28. EMULATOR	196
29. IN SYSTEM PROGRAMMING.....	199
29.1 Getting Started.....	199
29.2 Basic ISP S/W Information	200
29.3 Hardware Conditions to Enter the ISP Mode.....	202
29.4 Entering ISP mode at power on time.....	203
29.5 USB-SIO-ISP Board	204
30. INSTRUCTION SET.....	205
30.1 Terminology List	205
30.2 Instruction Map	206
30.3 Instruction Set.....	207

MC81F4x16

8 bit MCU with 12-bit A/D Converter

1. OVERVIEW

1.1 Description

MC81F4x16 is a CMOS 8 bit MCU which provides a 16K bytes FLASH-ROM and 512 bytes RAM. It has following major features,

12 bit ADC : It has 15 ch A/D Converter which can be used to measure minute electronic voltage and currents.

810 Core : Same with ABOV's 800 Core but twice faster. 800 Core use a divided system clock but 810 Core use a system clock directly

Power Consumption – Sub Active Mode: To decrease the power consumption, It can be operated with sub clock(32.768KHz).

1.2 Features

ROM (FLASH) : 16K Bytes
(Endurance: 100 cycle)

SRAM : 512 Bytes

Minimum Instruction Execution Time

166nsec (@12MHz 2 Cycle NOP Instruction)

Power down mode

IDLE, STOP, SLEEP mode

Sub-Active mode

(Operates at 32.768KHz sub clock)

General Purpose I/O (GPIO)

44-pin : 42 ports, 42-pin : 40 ports

32-pin : 30 ports, 28-pin : 26 ports

24-pin : 22 ports, 20-pin : 18 ports

SIO : 1ch

Uart : 1ch

IIC slave : 1ch

Timer/ Counter

8Bit × 4ch (or 16Bit x 2ch)

PWM

(8Bit x 2ch or 16Bit x 1ch) + 10Bit × 3ch

Buzzer : 1ch (244 ~ 250KHz @8MHz)

Watch Timer (WT) : 8Bit × 1ch

Basic Interval Timer (BIT) : 8Bit × 1ch

Watch Dog Timer (WDT) : 8Bit × 1ch

12 Bit A/D Converter : 15 ch

Interrupt Sources : 27ch

External interrupts(EXT0~11) : 12ch

Timer0~3 Match/overflow : 8ch

WDT, BIT, WT : 3ch

SIO,UART(Tx/Rx), IIC : 4ch

Power On Reset (POR)

Reset release level (detect only rising)

Low Voltage Reset (LVR)

4 level detector (4.0V, 3.0V, 2.7V, 2.4V)

Operating Voltage & Frequency

2.2V – 5.5V : 1.0 - 4.2 MHz

2.7V – 5.5V : 1.0 - 8.0 MHz

4.0V – 5.5V : 1.0 – 12.0 MHz

Operating Temperature

- 40°C ~ 85°C

Oscillator Type

Crystal, Ceramic, RC

On-Chip RC-Oscillator (8/4/2/1MHz)

PKG Type

44MQFP, 42SDIP, 32SDIP/SOP,
28 SKDIP/SOP/QFN

24 SSOP

20 PDIP/SOP

1.3 Development Tools

The MC81F4x16 is supported by a full-featured macro assembler, C-Compiler, an in-circuit emulator CHOICE-Dr.[™], FLASH programmers and ISP tools. There are two different type of programmers such as single type and gang type. For more detail, Macro assembler operates under the MS-Windows 95 and up versioned Windows OS. And HMS800C compiler only operates under the MS-Windows 2000 and up versioned Windows OS.

Please contact sales part of ABOV semiconductor. And you can see more information at (<http://www.abov.co.kr>)



Figure 1-1 PGMplusUSB (Single Writer)



Figure 1-5 StandAlone Gang4 (for Mass Production)



Figure 1-2 SIO ISP (In System Programmer)



Figure 1-6 StandAlone Gang8 (for Mass Production)



Figure 1-3 StandAlone ISP
(VDD power is not supplied)



Figure 1-7 Choice-Dr (Emulator)



Figure 1-4 Ez-ISP
(VDD supplied Standalone type ISP)

1.4 Ordering Information

Device Name	FLASH ROM	RAM	Package
MC81F4216D	16K Bytes	512 Bytes	20_SOP
MC81F4216B			20_PDIP
MC81F4216U			24_QFN
MC81F4316S			24_SSOP
MC81F4316M			28_SOP
MC81F4316G			28_SKDIP
MC81F4316U			28_QFN
MC81F4316D			32_SOP
MC81F4316K			32_SDIP
MC81F4416K			42_SDIP
MC81F4416Q			44_MQFP

2. BLOCK DIAGRAM

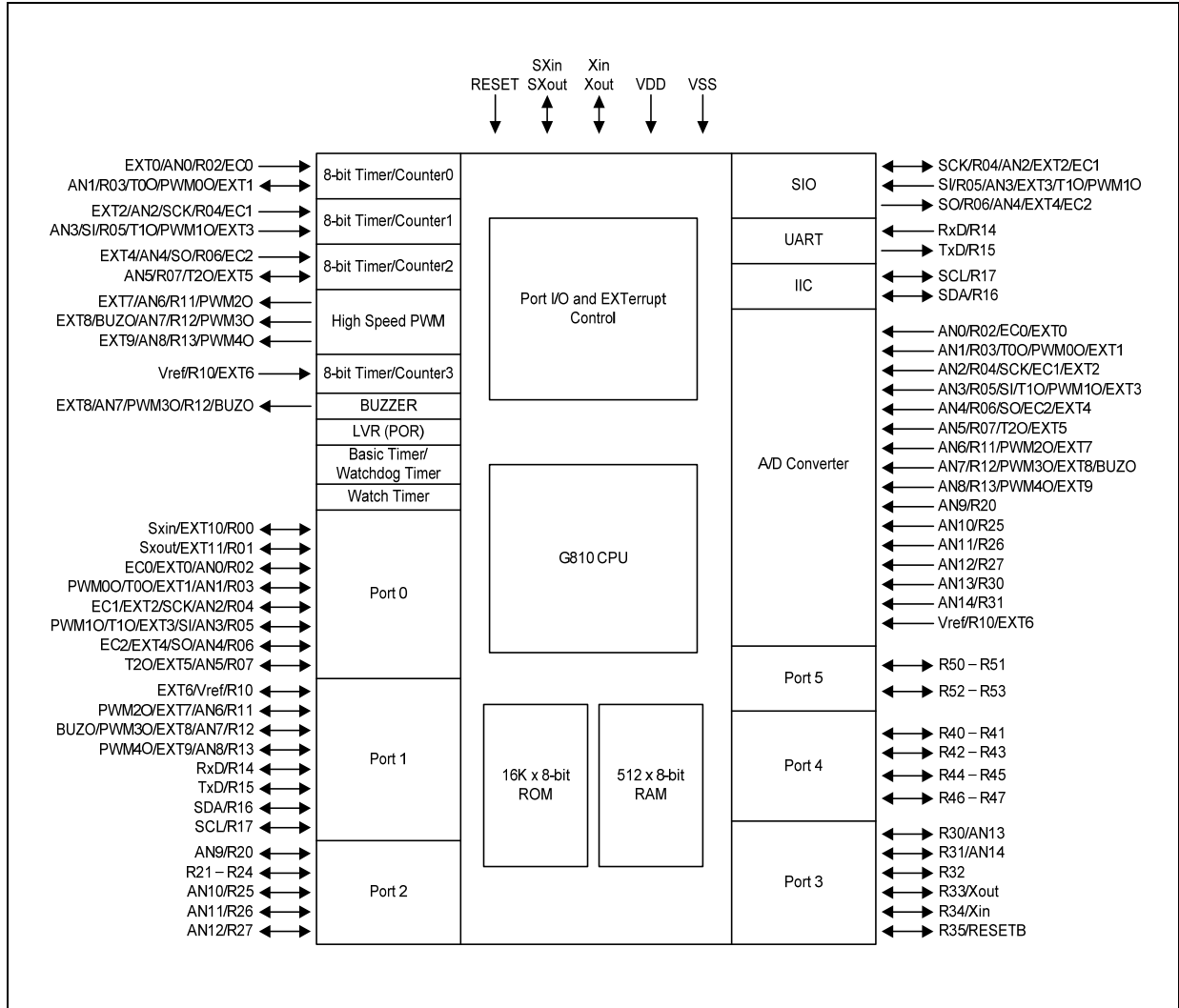
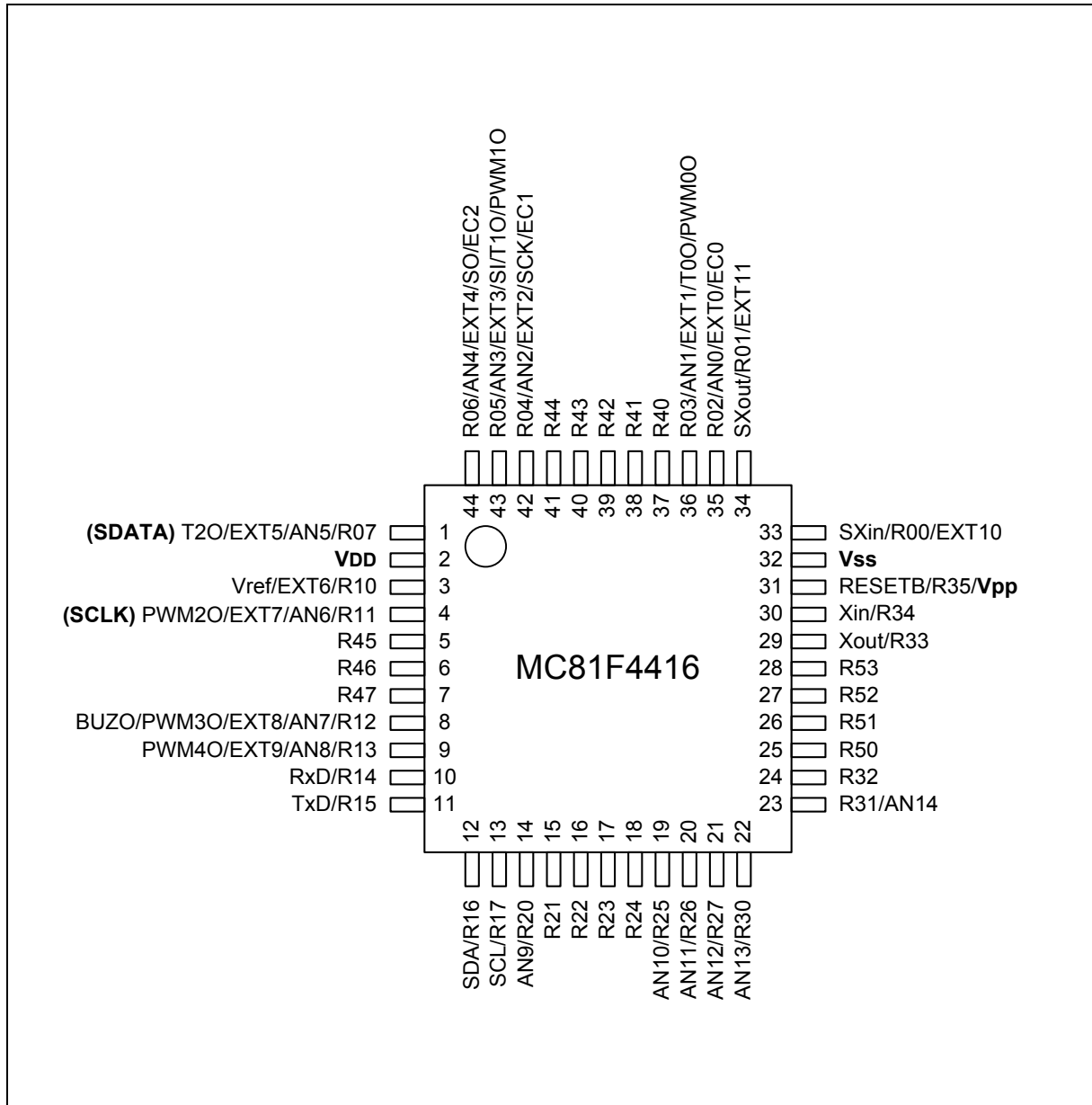

Figure 2-1 System Block Diagram

3. PIN ASSIGNMENT

3.1 44 MQFP



3.2 42 SDIP

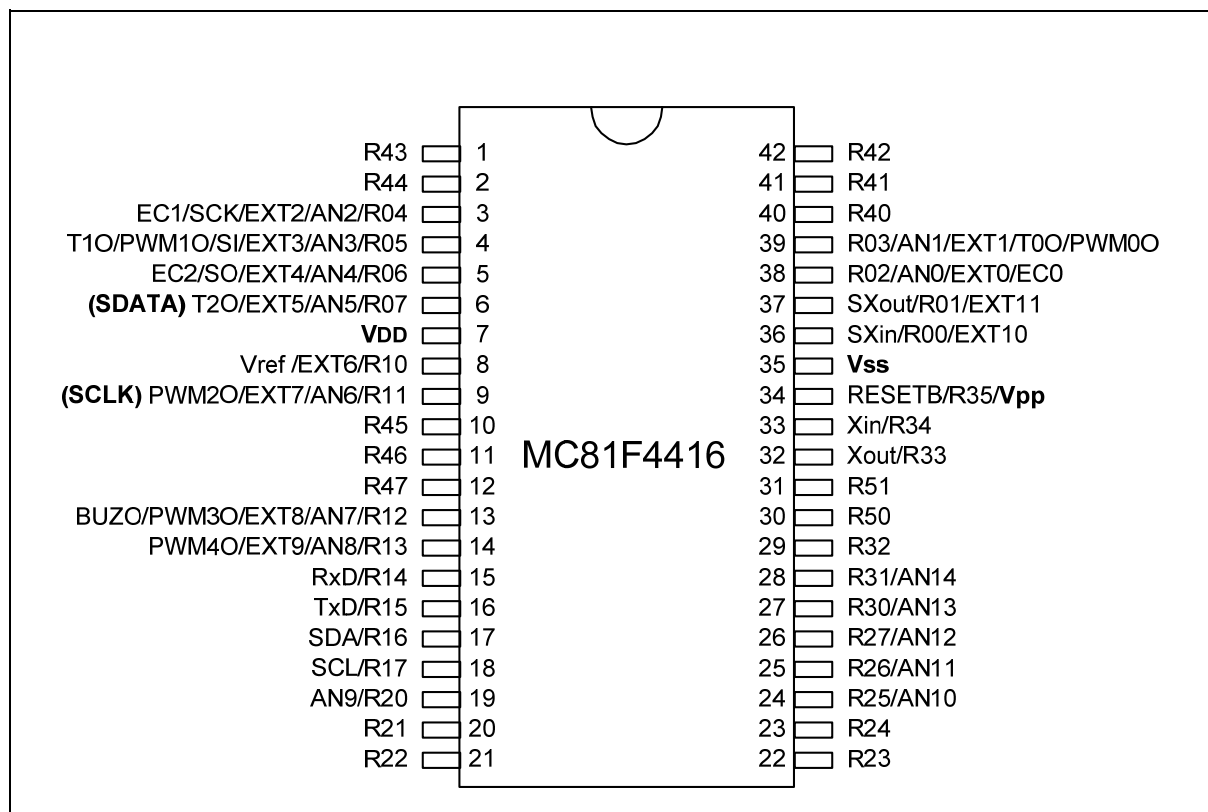

3.3 32 SDIP/SOP

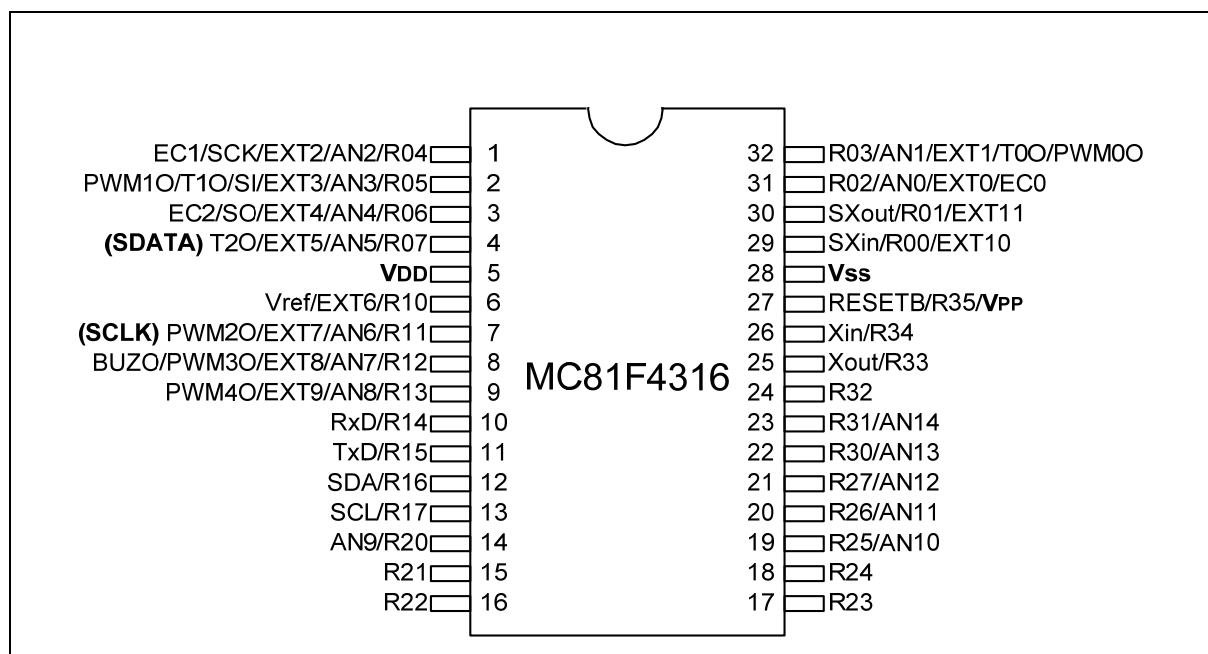

3.4 28 SKDIP/SOP

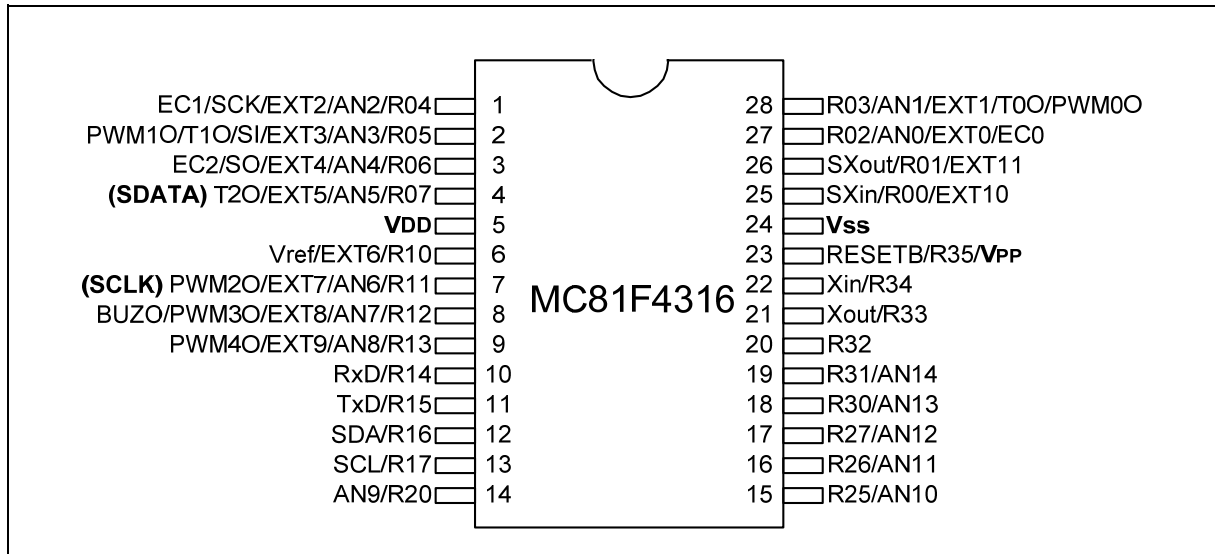

3.5 28 QFN

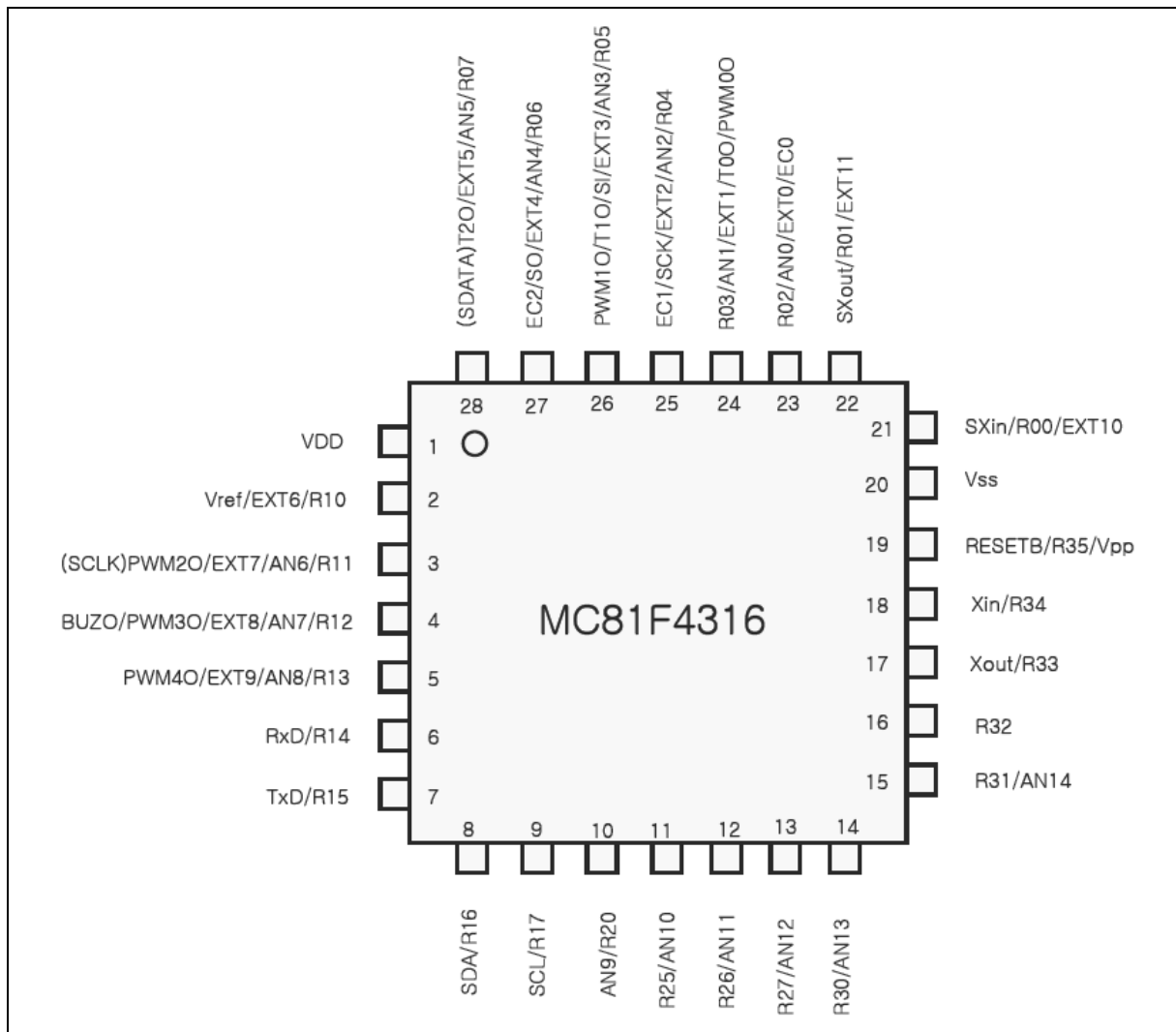

3.6 24 SSOP

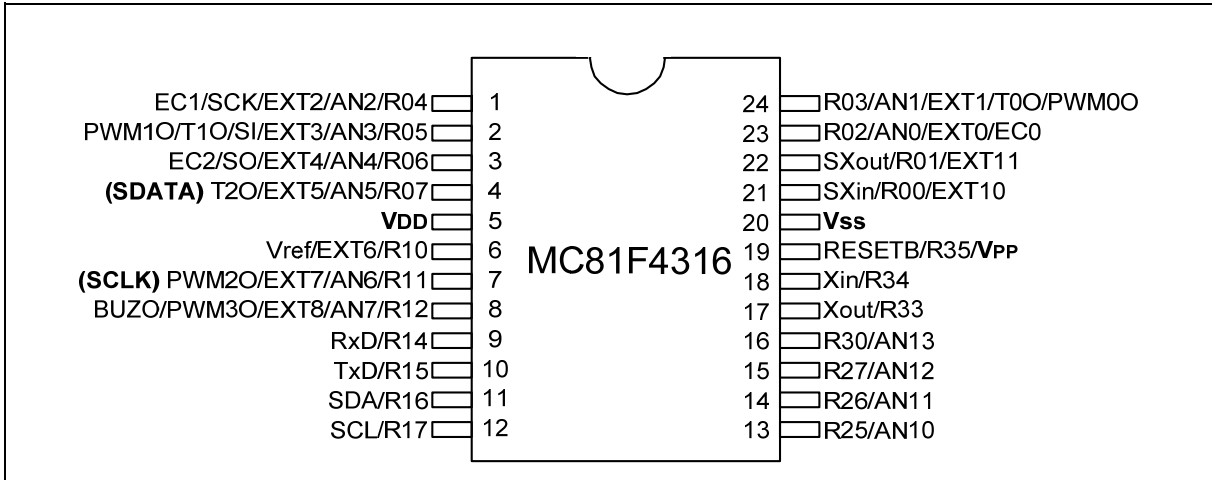

3.7 24 QFN

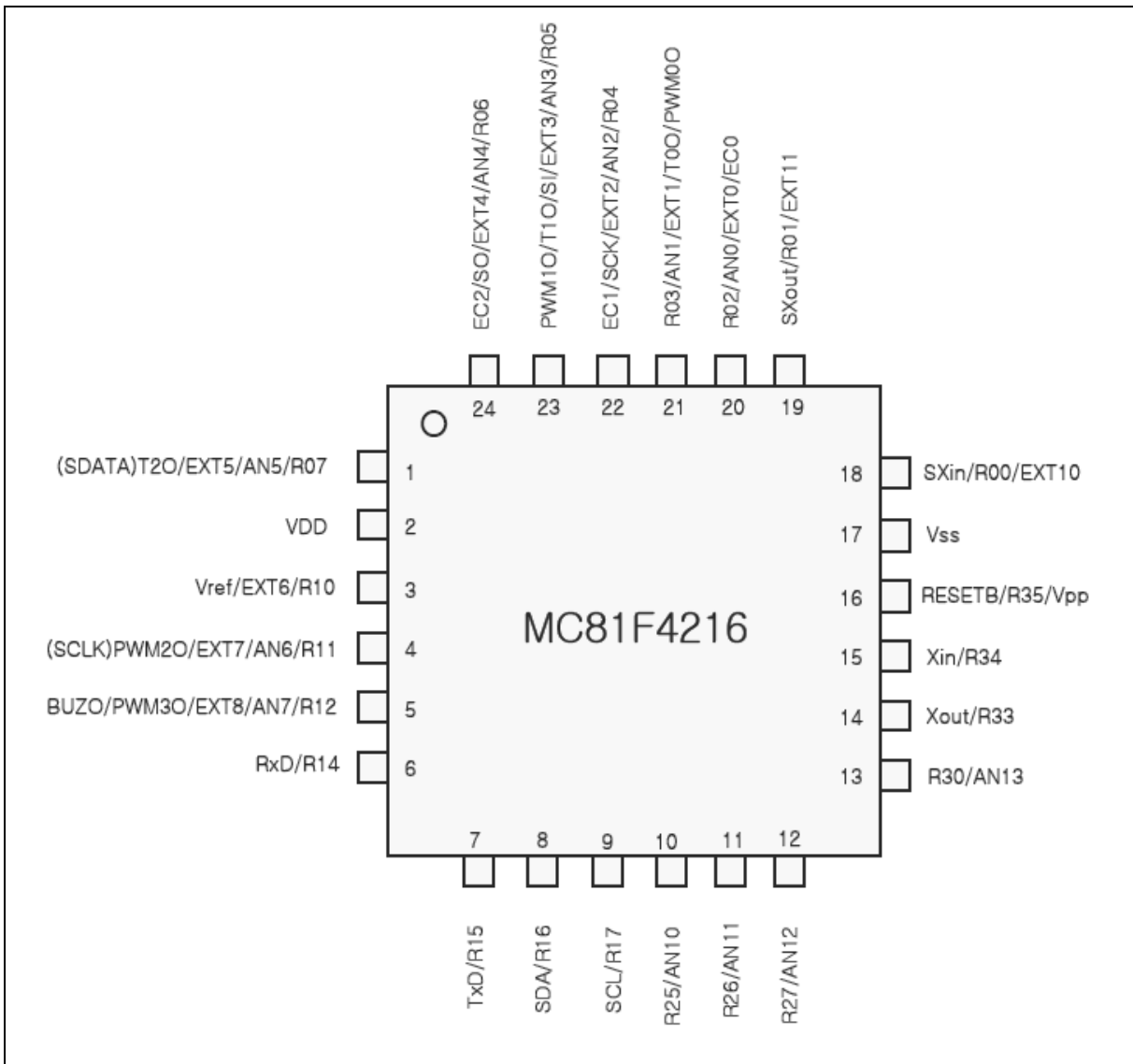

3.8 20 PDIP/SOP

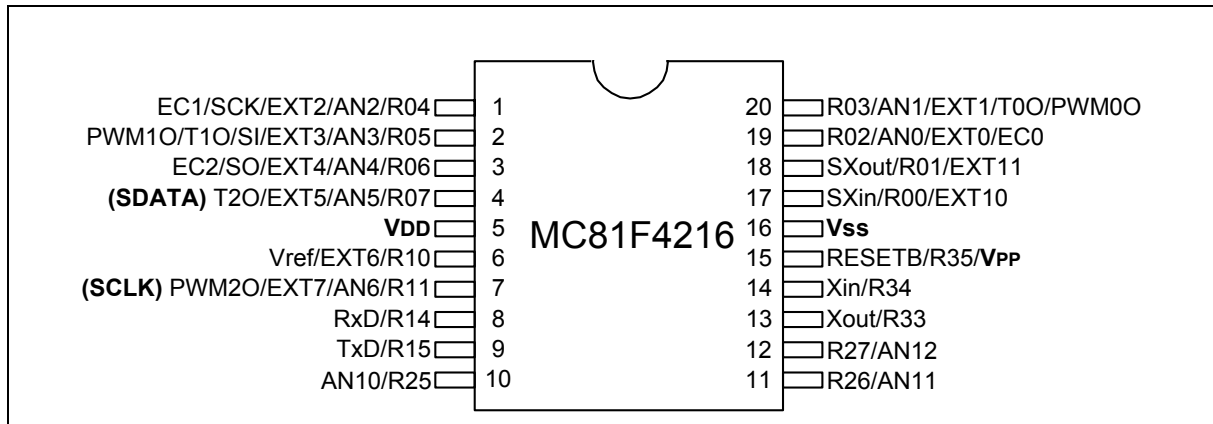

***Note**
*** You must set R12 port as an low OUTPUT mode even it is not exist in 20pin package.**
 *
 In fact, R12 port is exist in side of the package and it's reset status is input mode. If it is in input mode it course current leakage when the MCU falls in stop/sleep mode. So you must set it as an output mode before fall in stop/sleep.
 It is recommendable to set R12 port as an low OUTPUT mode at initial time.

3.9 Summary

I/O	Alternative functions	Pin number								Pin status at RESET
		44 (MQFP)	42 (SDIP)	32 (SDIP /SOP)	28 (QFN)	28 (SKDIP /SOP)	24 (SSOP)	24 (QFN)	20 (SOP)	
R00	EXT10/SXin	33	36	29	21	25	21	18	17	input
R01	EXT11/SXout	34	37	30	22	26	22	19	18	input
R02	AN0/EXT0/EC0/	35	38	31	23	27	23	20	19	input
R03	AN1/EXT1/T0O/PWM0O	36	39	32	24	28	24	21	20	input
R04	AN2/EXT2/EC1/SCK	42	3	1	25	1	1	22	1	input
R05	AN3/EXT3/SI/T1O/PWM1O	43	4	2	26	2	2	23	2	input
R06	AN4/EXT4/EC2/SO	44	5	3	27	3	3	24	3	input
R07	AN5/EXT5/T2O	1	6	4	28	4	4	1	4	input
R10	Vref/EXT6	3	8	6	2	6	6	3	6	input
R11	AN6/EXT7/PWM2O	4	9	7	3	7	7	4	7	input
R12	AN7/EXT8/PWM3O/BUZO	8	13	8	4	8	8	5	x	input
R13	AN8/EXT9/PWM4O	9	14	9	5	9	x	x	x	Open-drain output
R14	RxD	10	15	10	6	10	9	6	8	Open-drain output
R15	TxD	11	16	11	7	11	10	7	9	Open-drain output
R16	SDA	12	17	12	8	12	11	8	x	Open-drain output
R17	SCL	13	18	13	9	13	12	9	x	Open-drain output
R20	AN9	14	19	14	10	14	x	x	x	Open-drain output
R21	-	15	20	15	x	x	x	x	x	Open-drain output
R22	-	16	21	16	x	x	x	x	x	Open-drain output
R23	-	17	22	17	x	x	x	x	x	Open-drain output
R24	-	18	23	18	x	x	x	x	x	Open-drain output
R25	AN10	19	24	19	11	15	13	10	10	Open-drain output
R26	AN11	20	25	20	12	16	14	11	11	Open-drain output
R27	AN12	21	26	21	13	17	15	12	12	Open-drain output
R30	AN13	22	27	22	14	18	16	13	x	Open-drain output
R31	AN14	23	28	23	15	19	x	x	x	Open-drain output
R32	-	24	29	24	16	20	x	x	x	Open-drain output
R33	Xout	29	32	25	17	21	17	14	13	input
R34	Xin	30	33	26	18	22	18	15	14	input
R35	RESETB	31	34	27	19	23	19	16	15	input

I/O	Alternative functions	Pin number								Pin status at RESET
		44 (MQFP)	42 (SDI P)	32 (SDI P/SOP)	28 (QFN)	28 (SKDIP /SOP)	24 (SSOP)	24 (QFN)	20 (SOP)	
R40	-	37	40	x	x	x	x	x	x	Open-drain output
R41	-	38	41	x	x	x	x	x	x	Open-drain output
R42	-	39	42	x	x	x	x	x	x	Open-drain output
R43	-	40	1	x	x	x	x	x	x	Open-drain output
R44	-	41	2	x	x	x	x	x	x	Open-drain output
R45	-	5	10	x	x	x	x	x	x	Open-drain output
R46	-	6	11	x	x	x	x	x	x	Open-drain output
R47	-	7	12	x	x	x	x	x	x	Open-drain output
R50	-	25	30	x	x	x	x	x	x	Open-drain output
R51	-	26	31	x	x	x	x	x	x	Open-drain output
R52	-	27	x	x	x	x	x	x	x	Open-drain output
R53	-	28	x	x	x	x	x	x	x	Open-drain output
VDD	-	2	7	5	1	5	5	2	5	-
VSS	-	32	35	28	20	24	20	17	16	-

Note :

Some pins are initialized by open-drain output mode, when the device is reset. Because the pins are hidden in 16 pin package and it is stable that hidden pins are in open-drain-output mode.

The reset status of MC81F4x16 is designed under consideration of 16 pin package of MC81F4204. Because MC81F4204 is a reduced version of MC81F4x16. (So the Eva.board(emulator) is shared)

4. PACKAGE DIAGRAM

4.1 44 MQFP - MC81F4416Q

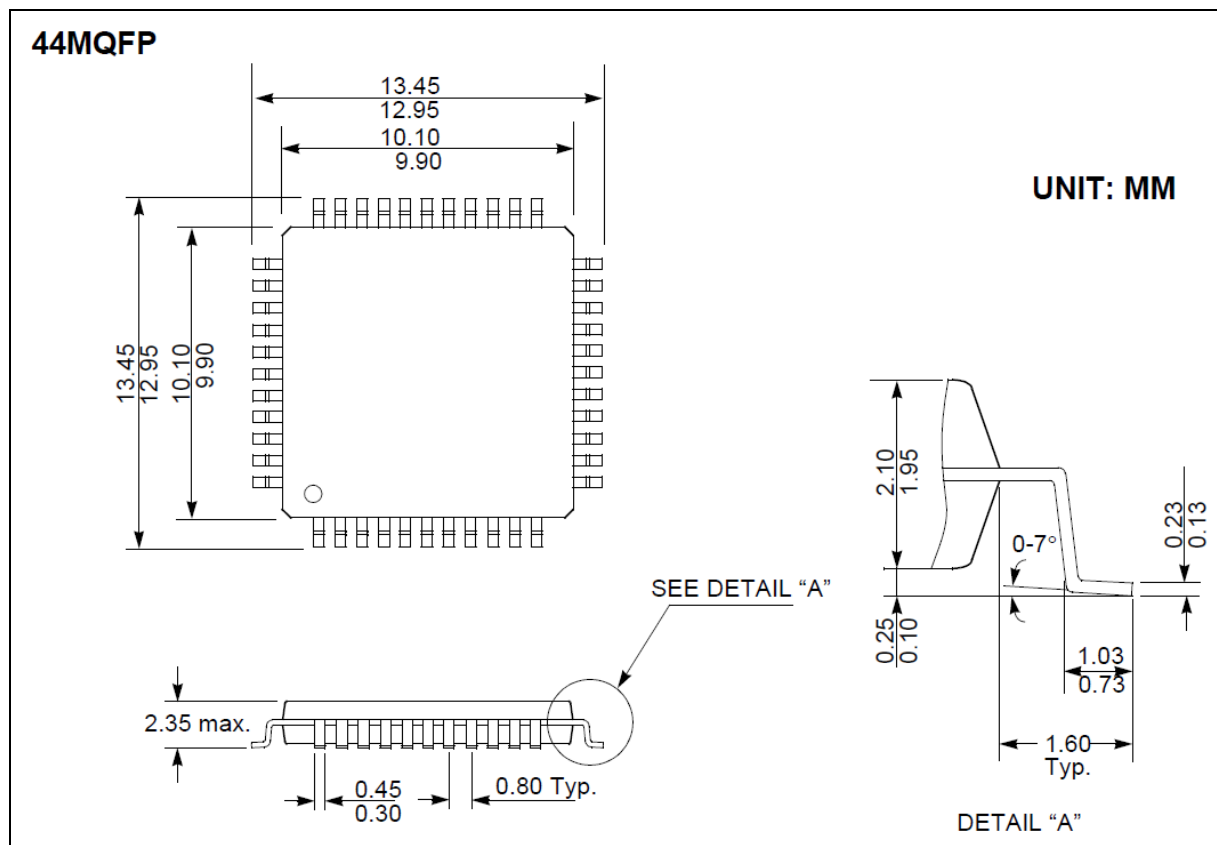

4.2 42 SDIP - MC81F4416K

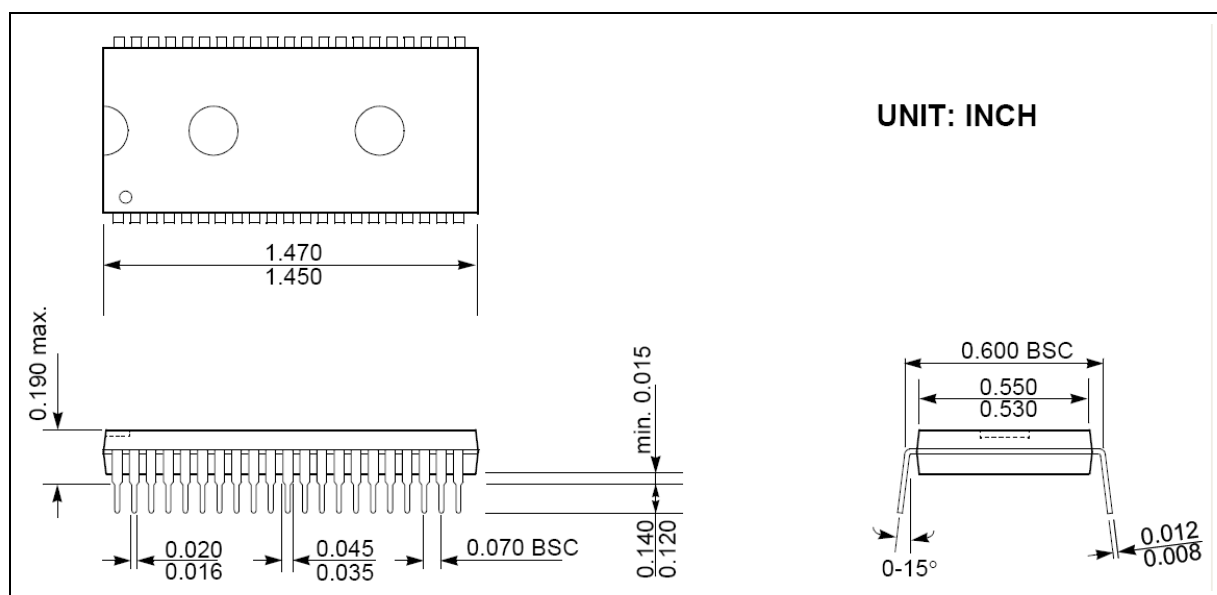

4.3 32 SDIP - MC81F4316K

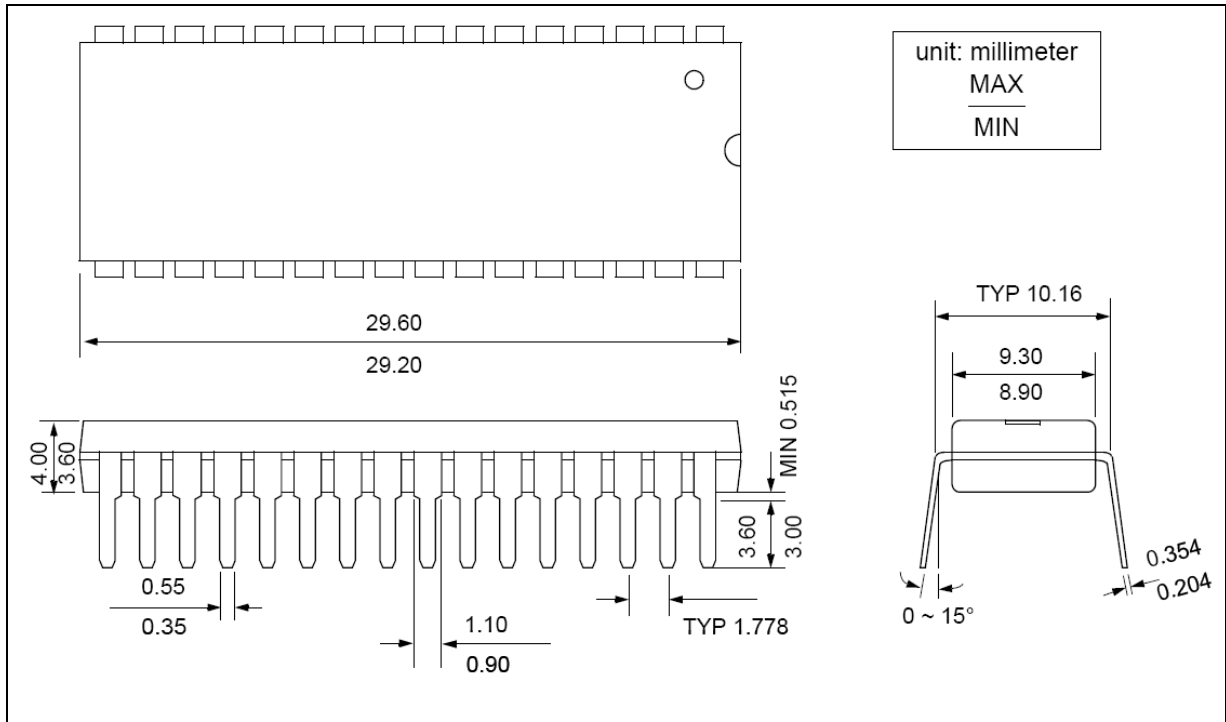

4.4 32 SOP - MC81F4316D

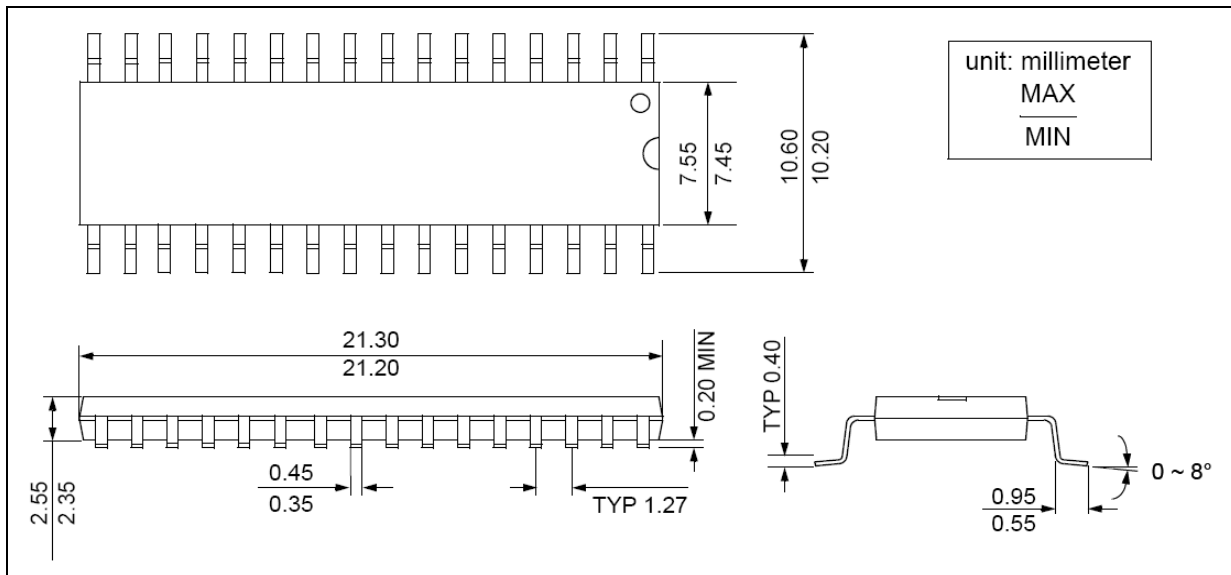

4.5 28 SKDIP - MC81F4316G

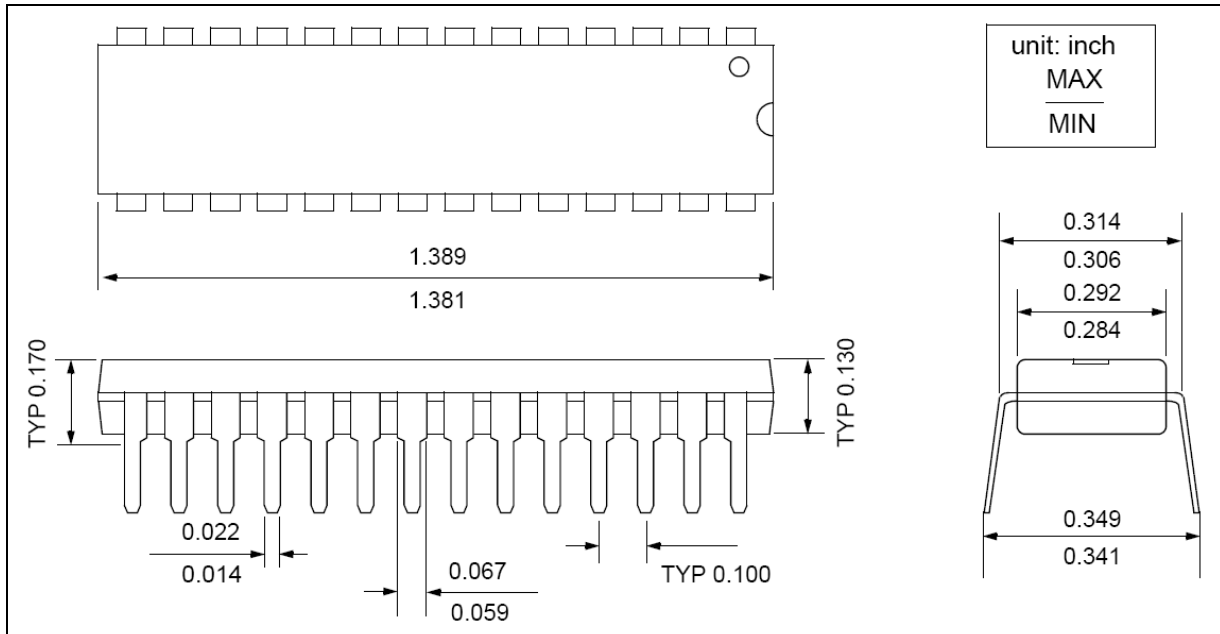

4.6 28 SOP - MC81F4316M

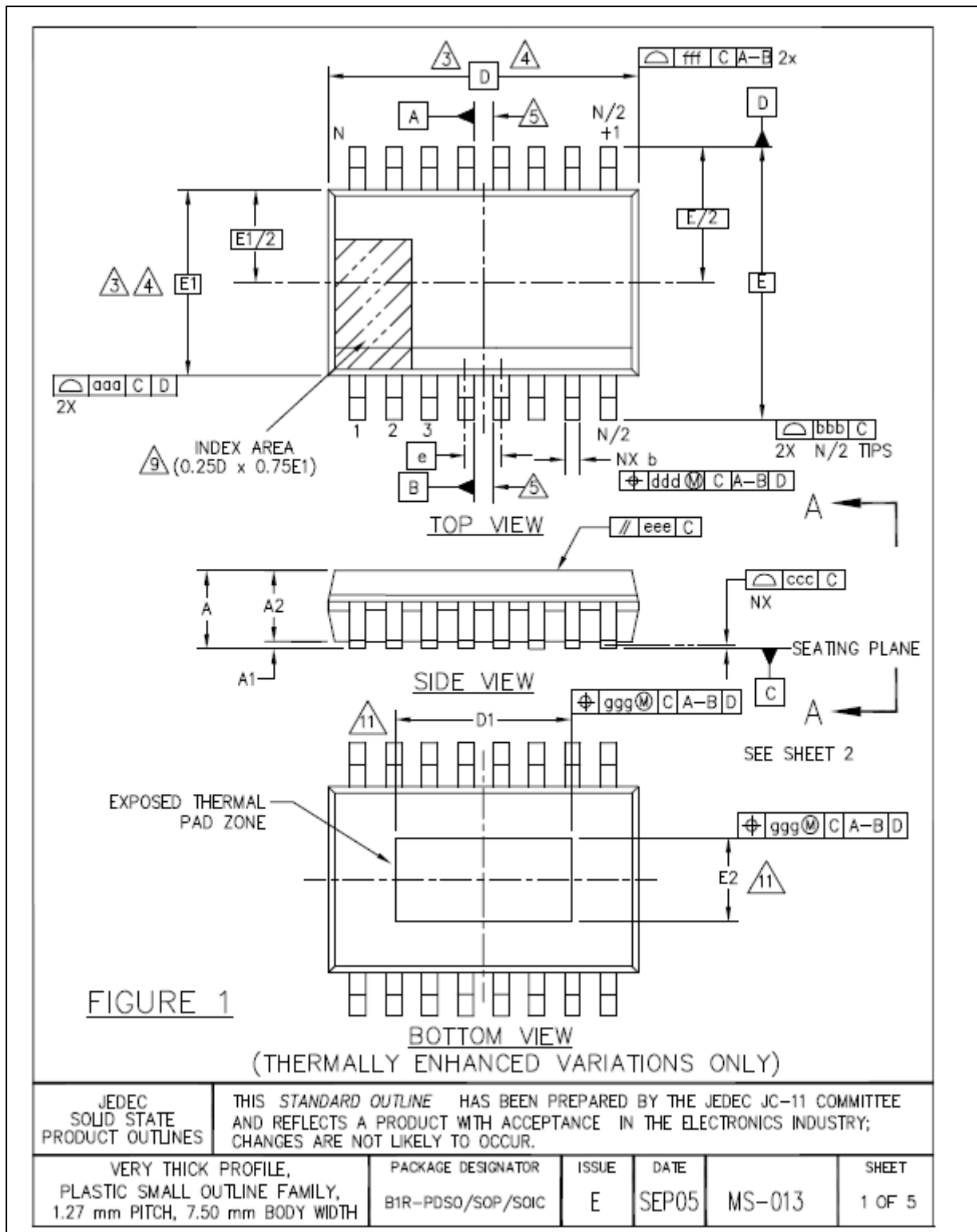

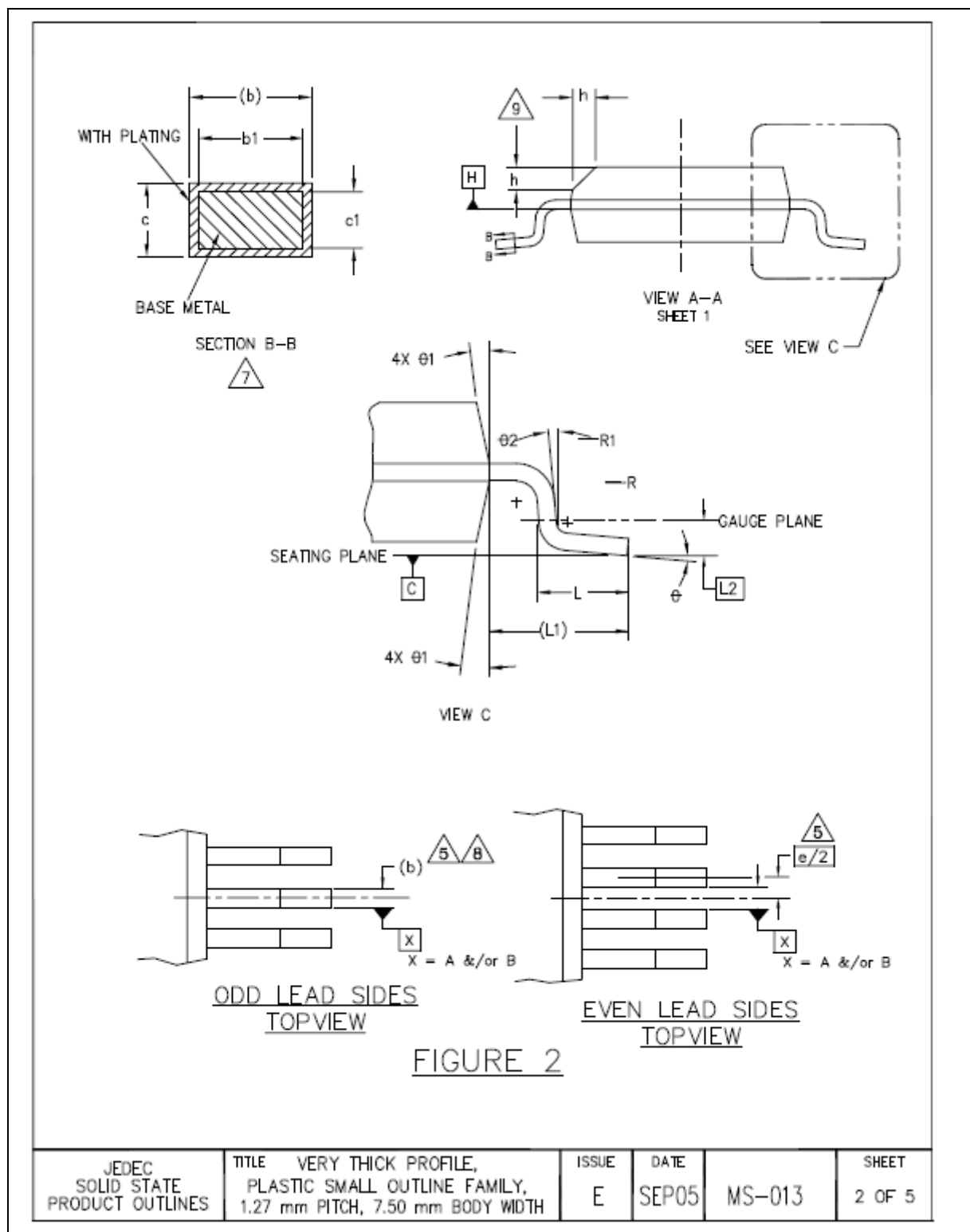

SYMBOL	COMMON DIMENSIONS			NOTE
	MIN	NOM	MAX	
A2	2.05	--	--	
b	0.31	--	0.51	7,8
b1	0.27	--	0.48	7,8
c	0.20	--	0.33	7
c1	0.20	--	0.30	7
E	10.30 BSC			
E1	7.50 BSC			3,4
e	1.27 BSC			
L	0.40	--	1.27	
L1	1.40 REF			
L2	0.25 BSC			
R	0.07	--	--	
R1	0.07	--	--	
h	0.25	--	0.75	9
ϕ	0"	--	8"	
ϕ1	5"	--	15"	
ϕ2	0"	--	--	
NOTE	1,2			
REF	11-720S			
ISSUE	E			

SYMBOL	TOLERANCES OF FORM AND POSITION	NOTE
aaa	0.10	
bbb	0.33	
ccc	0.10	
ddd	0.25	
eee	0.10	
fff	0.20	
ggg	0.15	
NOTE	1,2	
REF	11-720S	
ISSUE	E	

VARIATION TABLES

STANDARD

VARIATION SYMBOL	AA	AB	AC	AD	AE	AF	NOTE
A	MIN	----					
	NOM	----					
	MAX	2.65					
A1	MIN	0.10					10
	NOM	----					
	MAX	0.30					
D BSC	10.30	11.55	12.80	15.40	17.90	9.00	3,4
N	16	18	20	24	28	14	6
NOTE							
REF	11-720S						
ISSUE	E						

THERMAL

VARIATION SYMBOL	BA	BB	BC	BD	BE	BF	NOTE
A	MIN	----					
	NOM	----					
	MAX	2.50					
A1	MIN	0.00					10
	NOM	----					
	MAX	0.15					
D BSC	10.30	11.55	12.80	15.40	17.90	9.00	3,4
D1	MIN	3.00	3.00	3.00	3.00	3.00	11
	NOM	----	----	----	----	----	
	MAX	----	----	----	----	----	
E2	MIN	2.00	2.00	2.00	2.00	2.00	11
	NOM	----	----	----	----	----	
	MAX	----	----	----	----	----	
N	16	18	20	24	28	14	6
NOTE							
REF	11-720S						
ISSUE	E						

JEDEC
SOLID STATE
PRODUCT OUTLINES

TITLE VERY THICK PROFILE,
PLASTIC SMALL OUTLINE FAMILY,
1.27 mm PITCH, 7.50 mm BODY WIDTH

ISSUE
E

DATE
SEP05

MS-013

SHEET
3 OF 5

NOTES:

1. DIMENSIONING AND TOLERANCING PER ASME Y14.5M-1994.

2. DIMENSIONS IN MILLIMETERS (ANGLES IN DEGREES)



DIMENSION D DOES NOT INCLUDE MOLD FLASH, PROTRUSIONS OR GATE BURRS. MOLD FLASH, PROTRUSIONS OR GATE BURRS SHALL NOT EXCEED 0.15 mm PER END. DIMENSION E1 DOES NOT INCLUDE INTERLEAD FLASH OR PROTRUSION. INTERLEAD FLASH OR PROTRUSION SHALL NOT EXCEED 0.25 mm PER SIDE. D AND E1 DIMENSIONS ARE DETERMINED AT DATUM H



THE PACKAGE TOP MAY BE SMALLER THAN THE PACKAGE BOTTOM. DIMENSIONS D AND E1 ARE DETERMINED AT THE OUTERMOST EXTREMES OF THE PLASTIC BODY EXCLUSIVE OF MOLD FLASH, TIE BAR BURRS, GATE BURRS AND INTERLEAD FLASH, BUT INCLUDING ANY MISMATCH BETWEEN THE TOP AND BOTTOM OF THE PLASTIC BODY.



DATUMS A & B TO BE DETERMINED AT DATUM H.

6 "N" IS THE MAXIMUM NUMBER OF TERMINAL POSITIONS FOR THE SPECIFIED PACKAGE LENGTH.



THE DIMENSIONS APPLY TO THE FLAT SECTION OF THE LEAD BETWEEN 0.10 TO 0.25 mm FROM THE LEAD TIP.



DIMENSION 'b' DOES NOT INCLUDE DAMBAR PROTRUSION. ALLOWABLE DAMBAR PROTRUSION SHALL BE 0.10 mm TOTAL IN EXCESS OF THE "b" DIMENSION MAXIMUM MATERIAL CONDITION. THE DAMBAR MAY NOT BE LOCATED ON THE LOWER RADIUS OF THE FOOT.



THIS CHAMFER FEATURE IS OPTIONAL. IF IT IS NOT PRESENT, THEN A PIN 1 IDENTIFIER MUST BE LOCATED WITHIN THE INDEX AREA INDICATED



'A1' IS DEFINED AS THE VERTICAL DISTANCE FROM THE SEATING PLANE TO THE LOWEST POINT ON THE PACKAGE BODY EXCLUDING THE LID AND OR THERMAL ENHANCEMENT ON CAVITY DOWN PACKAGE CONFIGURATIONS.



'D1' AND 'E2' MINIMUM DIMENSIONS OF THERMALLY ENHANCED TYPES ARE VARIABLES DEPENDING ON DEVICE FUNCTION (DIE PADDLE SIZE). 'D1' AND 'E2' MAXIMUM DIMENSIONS CAN BE EQUAL TO 'D' AND 'E1' MAXIMUM DIMENSIONS. END USER SHOULD VERIFY ACTUAL SIZE OF EXPOSED THERMAL PAD FOR SPECIFIC DEVICE APPLICATION.

JEDEC SOLID STATE PRODUCT OUTLINES	TITLE VERY THICK PROFILE, PLASTIC SMALL OUTLINE FAMILY, 1.27 mm PITCH, 7.50 mm BODY WIDTH	ISSUE E	DATE SEP05	MS-013	SHEET 4 OF 5
--	---	------------	---------------	--------	-----------------

4.7 28 QFN - MC81F4316U

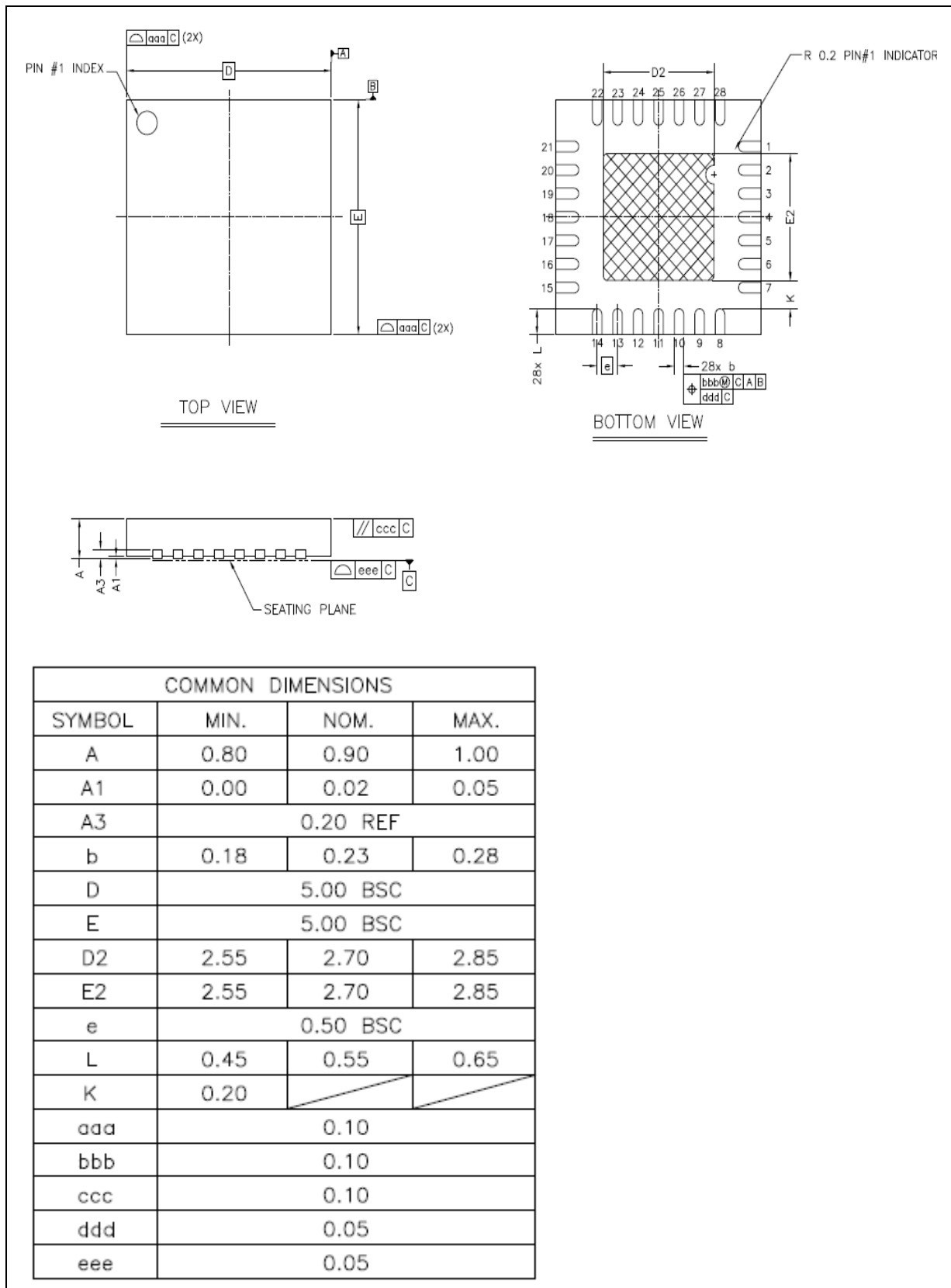

COMMON DIMENSIONS			
SYMBOL	MIN.	NOM.	MAX.
A	0.80	0.90	1.00
A1	0.00	0.02	0.05
A3	0.20 REF		
b	0.18	0.23	0.28
D	5.00 BSC		
E	5.00 BSC		
D2	2.55	2.70	2.85
E2	2.55	2.70	2.85
e	0.50 BSC		
L	0.45	0.55	0.65
K	0.20		
aaa	0.10		
bbb	0.10		
ccc	0.10		
ddd	0.05		
eee	0.05		

NOTES :

1. DRAWING CONFORM TO JEDEC REFERENCE MO-220.
2. DIMENSIONING AND TOLERANCING SCHEMES CONFORM TO ASEM Y14.5M-1994.
3. ALL DIMENSIONS ARE IN MILLIMETERS.
4.  HATCH AREA IS SOLDERABLE EXPOSED PAD.
5. MAXIMUM ALLOWABLE BURR IS 0.050mm IN ALL DIRECTIONS.

4.8 24 SSOP - MC81F4316S

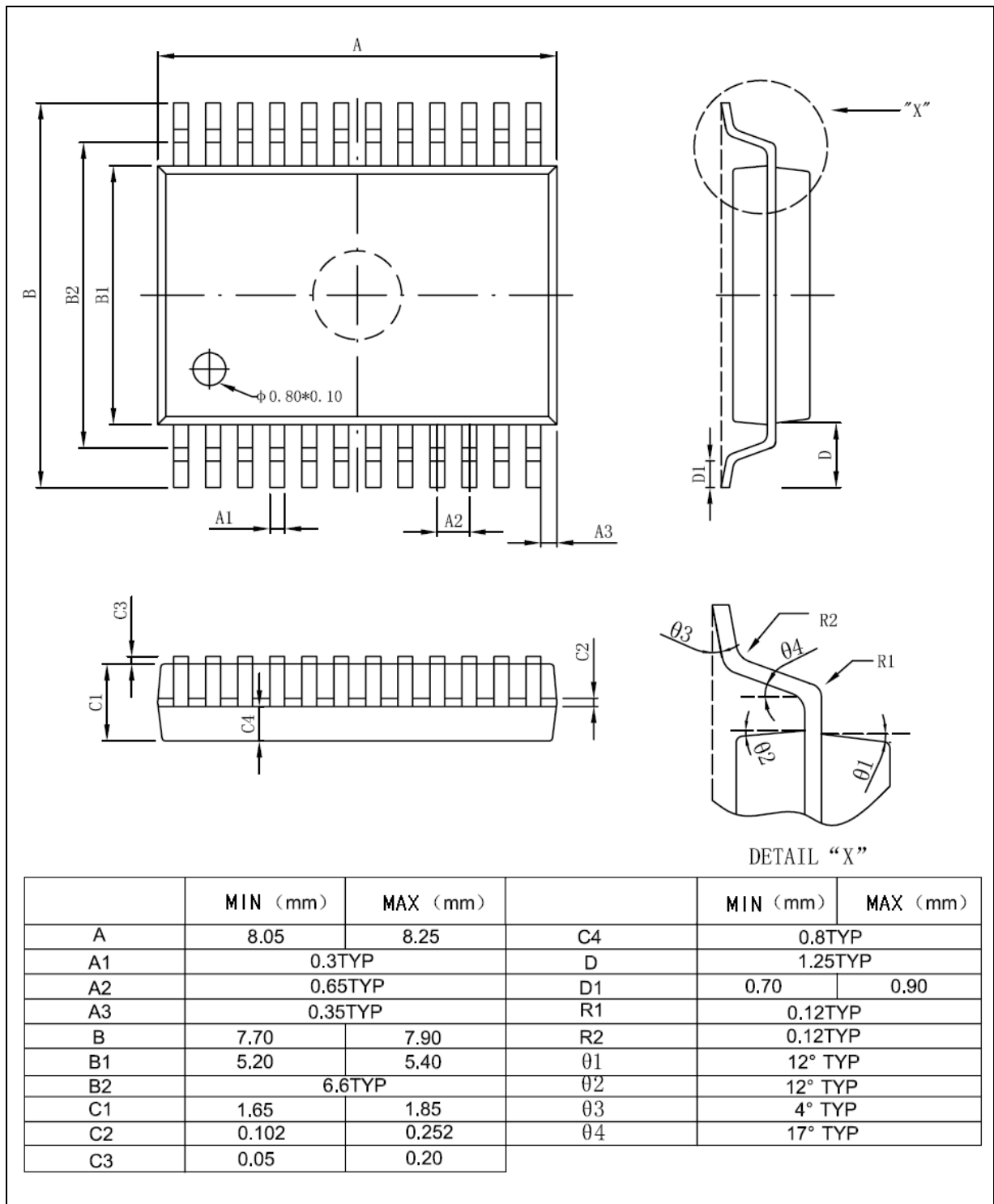

4.9 24 QFN - MC81F4216U

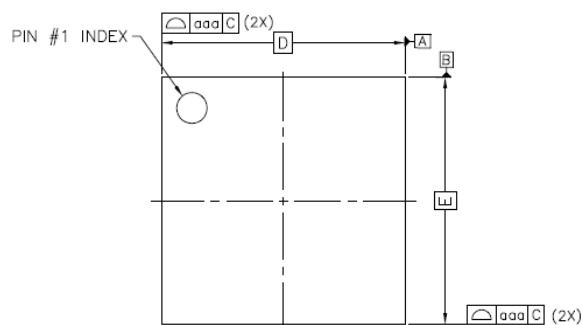

TOP VIEW

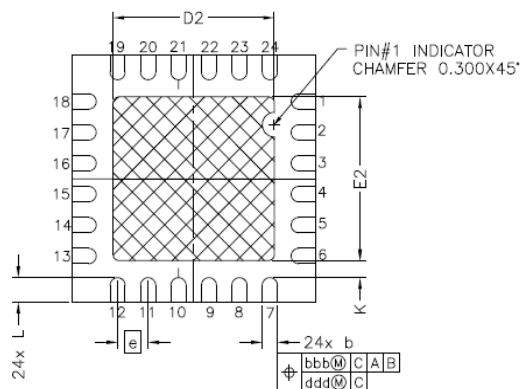

BOTTOM VIEW

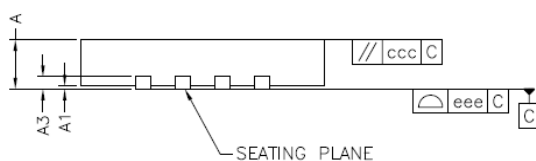

COMMON DIMENSIONS			
SYMBOL	MIN.	NOM.	MAX.
A	0.70	0.75	0.80
A1	0.00	0.02	0.05
A3	0.20 REF		
b	0.18	0.25	0.30
D	4.00 BSC		
E	4.00 BSC		
D2	2.50	2.65	2.80
E2	2.50	2.65	2.80
e	0.50 BSC		
L	0.35	0.40	0.45
K	0.20		
aaa	0.10		
bbb	0.10		
ccc	0.10		
ddd	0.05		
eee	0.08		

NOTES :

1. DRAWING CONFORM TO JEDEC REFERENCE MO-220.
2. DIMENSIONING AND TOLERANCING SCHEMES CONFORM TO ASEM Y14.5M-1994.
3. ALL DIMENSIONS ARE IN MILLIMETERS.
4. HATCH AREA IS SOLDERABLE EXPOSED PAD.

4.10 20 PDIP - MC81F4216B

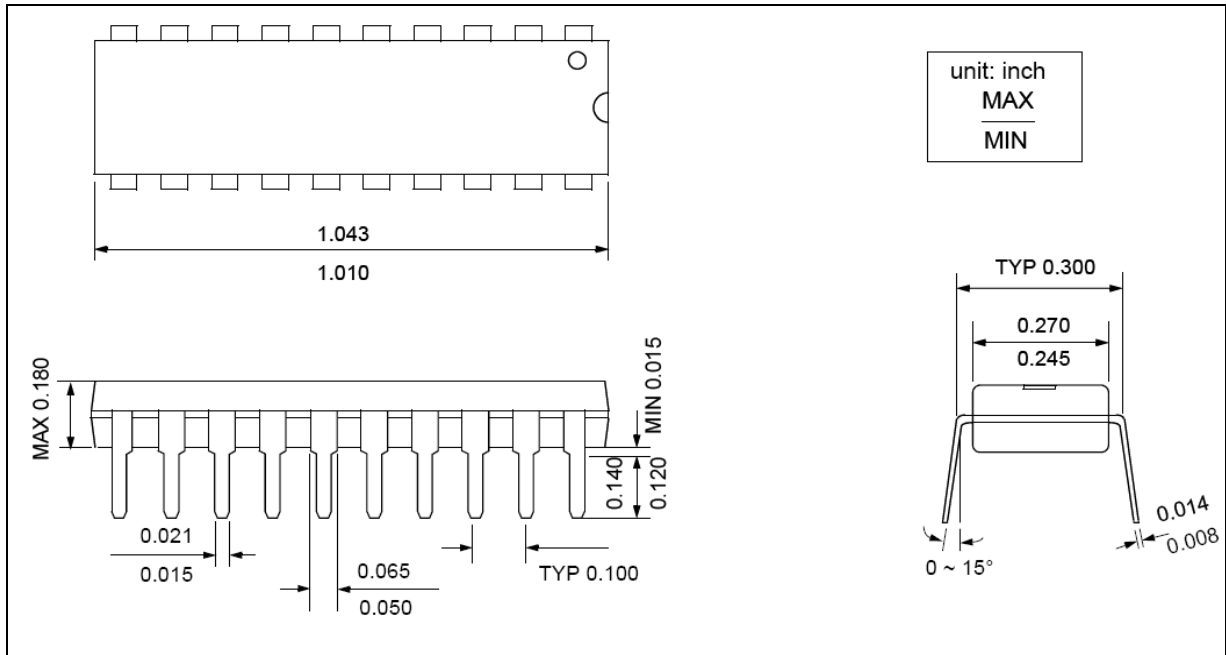

4.11 20 SOP - MC81F4216D

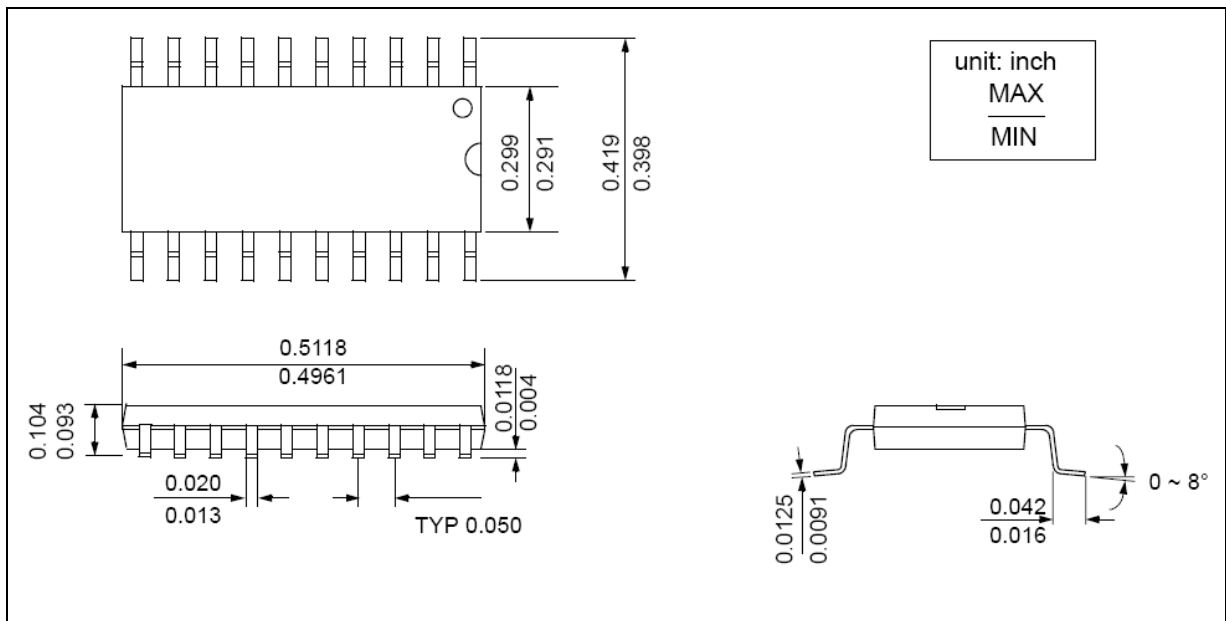

5. PIN DESCRIPTION

Pin Names	I/O	Function	Shared with
R00	I/O	This port is a 1-bit programmable I/O pin. Schmitt trigger input, Push-pull, or Open-drain output port. When used as an input port, a Pull-up resistor can be specified in 1-bit.	SXin/EXT10
R01			SXout/EXT11
R02			AN0/EC0/EXT0
R03			AN1/T00/ PWM00/EXT1
R04			AN2/EC1/SCK/ EXT2
R05			AN3/SI/EXT3/ T10/PWM10
R06			AN4/EC2/SO/ EXT4
R07			AN5/T20/EXT5
R10	I/O	This port is a 1-bit programmable I/O pin. Schmitt trigger input, Push-pull, or Open-drain output port. When used as an input port, a Pull-up resistor can be specified in 1-bit.	Vref/EXT6
R11			AN6/PWM20/ EXT7
R12			AN7/PWM30/ BUZO/EXT8
R13			AN8/PWM40/ EXT9
R14			RxD
R15			TxD
R16			SDA
R17			SCL
R20	I/O	This port is a 1-bit programmable I/O pin. Input, Push-pull, or Open-drain output port. When used as an input port, a Pull-up resistor can be specified in 1-bit.	AN9
R21			–
R22			–
R23			–
R24			–
R25			AN10
R26			AN11
R27			AN12
R30	I/O	This port is a 1-bit programmable I/O pin. Input, Push-pull, or Open-drain output port. When used as an input port, a Pull-up resistor can be specified in 1-bit.	AN13
R31			AN14
R32			–
R33			Xout
R34			Xin
R35			RESETB

Pin Names	I/O	Function	Shared with
R40	I/O	This port is a 1-bit programmable I/O pin. Input, Push-pull, or Open-drain output port. When used as an input port, a Pull-up resistor can be specified in 1-bit.	–
R41			–
R42			–
R43			–
R44			–
R45			–
R46			–
R47			–
R50	I/O	This port is a 1-bit programmable I/O pin. Input, Push-pull, or Open-drain output port. When used as an input port, a Pull-up resistor can be specified in 1-bit.	–
R51			–
R52			–
R53			–
EXT0	I/O	External interrupt input	R02/AN0/EC0
EXT1	I/O	External interrupt input/Timer 0 capture input	R03/AN1/T00/ PWM00
EXT2	I/O	External interrupt input	R04/AN2/SCK/ EC1
EXT3	I/O	External interrupt input/Timer 1 capture input	R05/AN3/SI/ T10/PWM10
EXT4	I/O	External interrupt input	R06/AN4/SO/ EC2
EXT5	I/O	External interrupt input/Timer 2 capture input	R07/AN5/T20
EXT6	I/O	External interrupt input/Timer 3 capture input	R10/Vref
EXT7	I/O	External interrupt input	R11/AN6/ PWM20
EXT8			R12/AN7/ PWM30/BUZO
EXT9			R13/AN8/ PWM40
EXT10			R00/SXin
EXT11			R01/SXout
T00	I/O	Timer 0 clock output	R03/AN1/EXT1/ PWM00
PWM00	I/O	PWM 0 clock output	R03/AN1/EXT1/ T00
EC0	I/O	Timer 0 event count input	R02/AN0/EXT0
T10	I/O	Timer 1 clock output	R05/AN3/EXT3/ SI/PWM10
PWM10	I/O	PWM 1 clock output	R05/AN3/EXT3/ SI/T10
EC1	I/O	Timer 1 event count input	R04/AN2/SCK/ EXT2

Pin Names	I/O	Function	Shared with
T2O	I/O	Timer 2 clock output	R07/AN5/EXT5
EC2	I/O	Timer 2 event count input	R06/AN4/SO/ EXT4
PWM2O	I/O	PWM 2 data output	R11/AN6/EXT7
PWM3O	I/O	PWM 3 data output	R12/AN7/EXT8/ BUZO
PWM4O	I/O	PWM 4 data output	R13/AN8/EXT9
BUZO	I/O	Buzzer signal output	R12/AN7/ PWM3O/EXT8
AN0	I/O	ADC input pins	R02/EXT0/EC0
AN1			R03/EXT1/T0O/ PWM0O
AN2			R04/EXT2/SCK /EC1
AN3			R05/EXT3/SI/ T1O/PWM1O
AN4			R06/EXT4/SO/ EC2
AN5			R07/EXT5/T2O
AN6			R11/EXT7/ PWM2O
AN7			R12/EXT8/ PWM3O/BUZO
AN8			R13/EXT9/ PWM4O
AN9			R20
AN10			R25
AN11			R26
AN12			R27
AN13			R30
AN14	R31		
RxD	I/O	UART data input	R14
TxD	I/O	UART data output	R15
SCL	I/O	IIC-bus clock input	R17
SDA	I/O	IIC-bus data input/output	R16
SCK	I/O	Serial clock input	R04/AN2/EC1/ EXT2
SI	I/O	Serial data input	R05/AN3/EXT3/ T1O/PWM1O
SO	I/O	Serial data output	R06/AN4/EC2/ EXT4

Pin Names	I/O	Function	Shared with
RESETB	I	System reset pin	R35
XIN	–	Main oscillator pins	R34
XOUT	–		R33
SXIN	–	Sub oscillator pins	R00/EXT10
SXOUT			R01/EXT11
VDD	–	Power input pins	–
VSS	–		–
VREF	–	A/D converter reference voltage	R10/EXT6

6. PORT STRUCTURE

[Schmitt trigger In] + [Out/Open-drain-out] + [Xin/Xout]

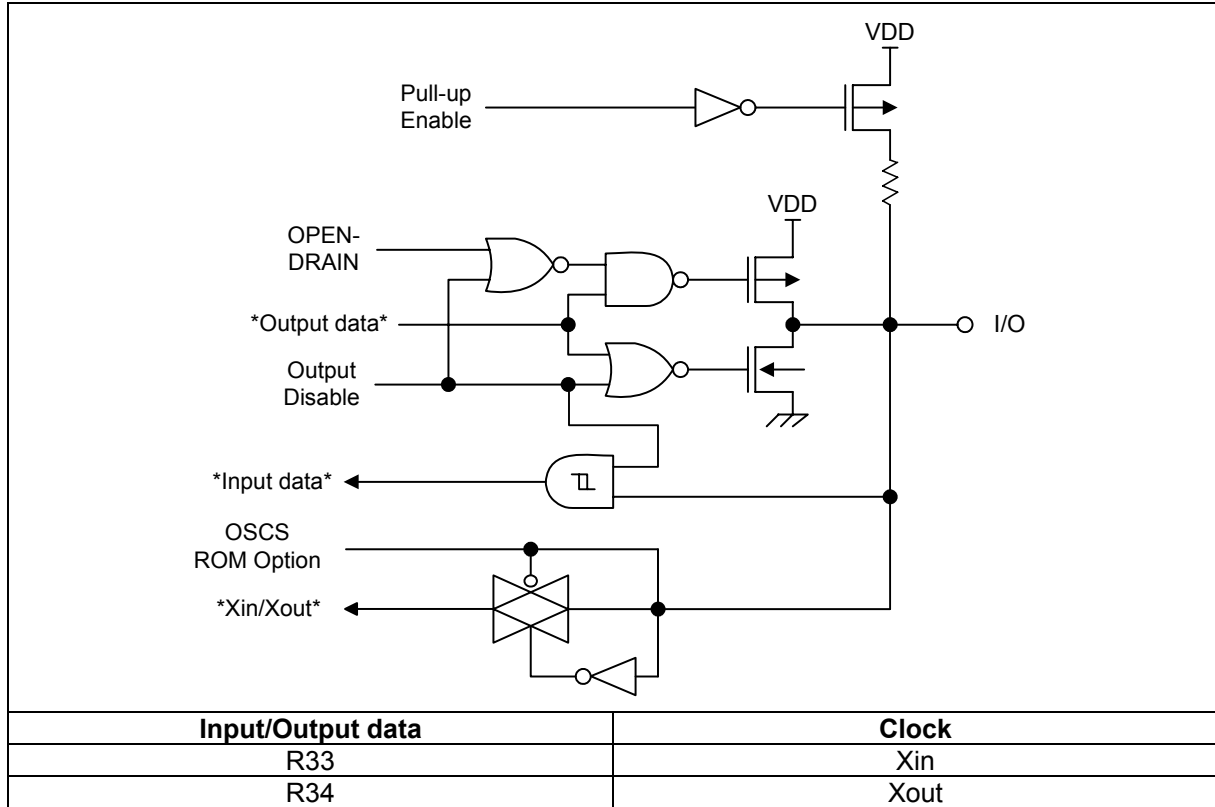

[Schmitt trigger In] + [Out/Open-drain-out] + [SXin/SXout]

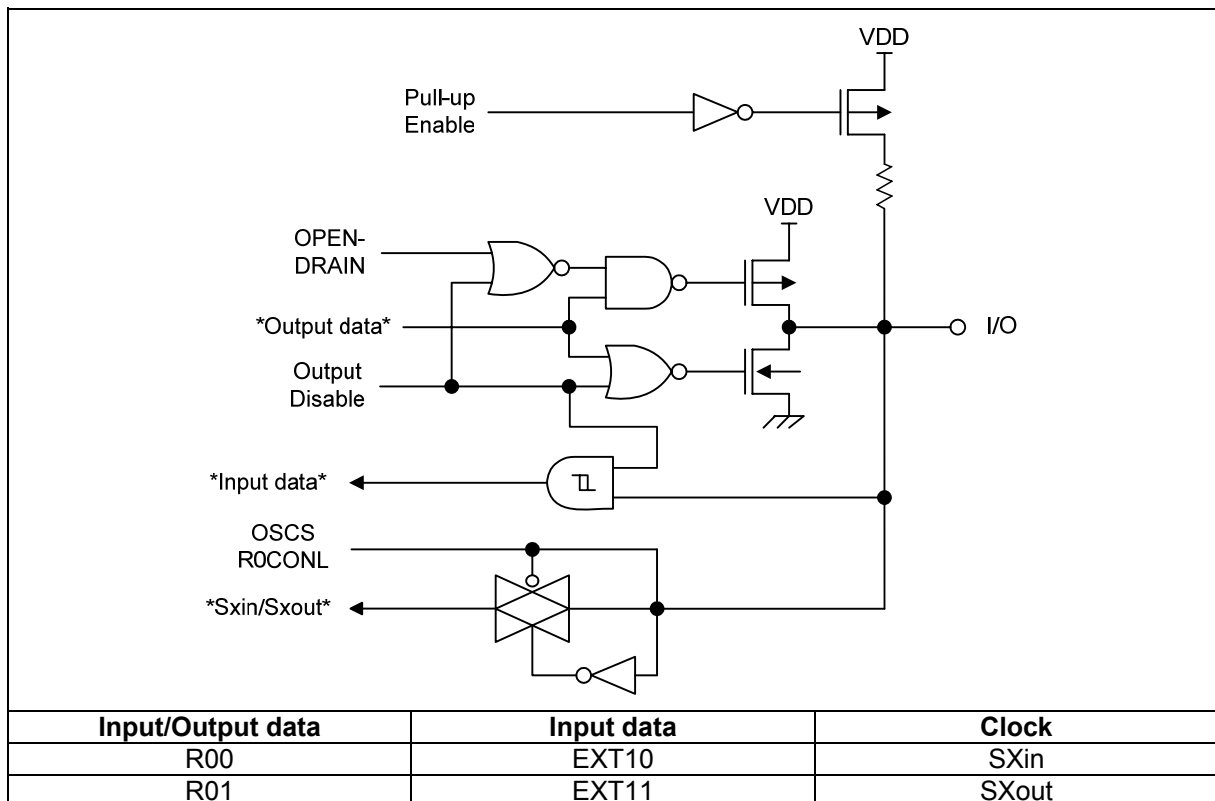

[Schmitt trigger In] + [Out / Open-drain-out] + [ADC]

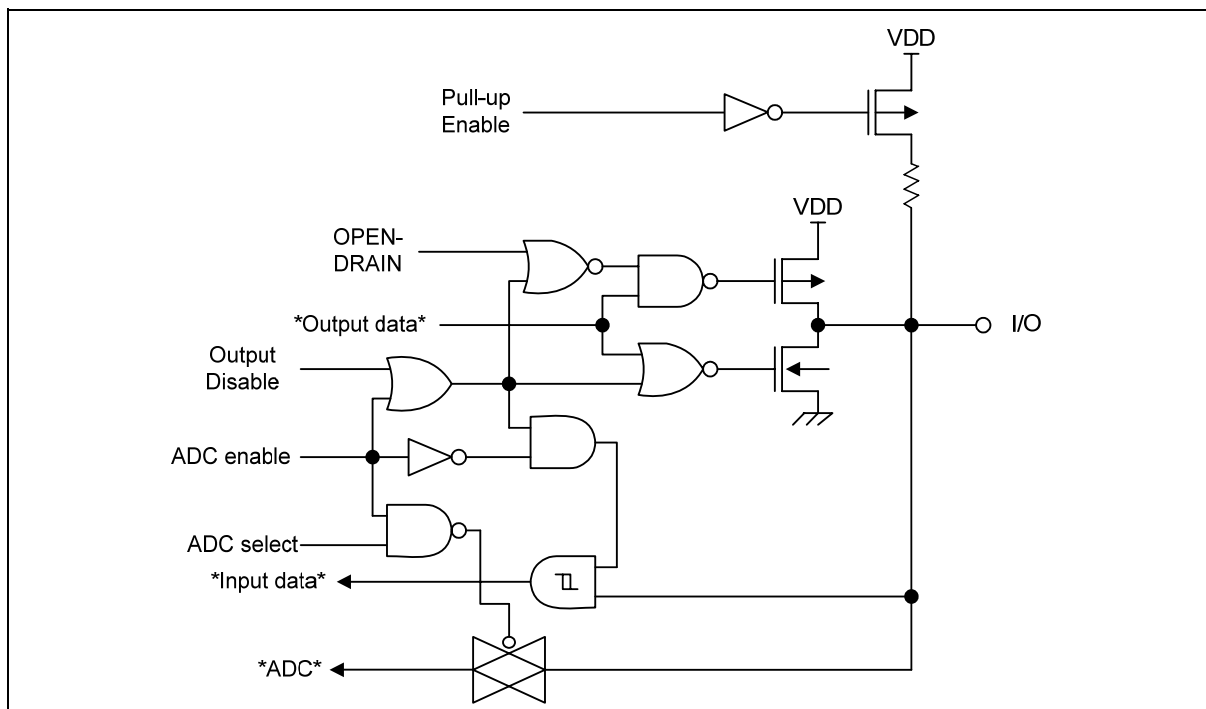

Input/Output data	Input data	Output data	ADC
R02	EXT0 / EC0	-	AN0
R03	EXT1	T00/PWM0O	AN1
R04	EXT2/SCK/EC1	SCK	AN2
R05	EXT3/SI	T10/PWM1O	AN3
R06	EXT4/EC2	SO	AN4
R07	EXT5	T20	AN5
R10	EXT6	-	Vref
R11	EXT7	PWM2O	AN6
R12	EXT8	PWM3O/BUZO	AN7
R13	EXT9	PWM4O	AN8

[Schmitt trigger In] + [Out / Open-drain-out]

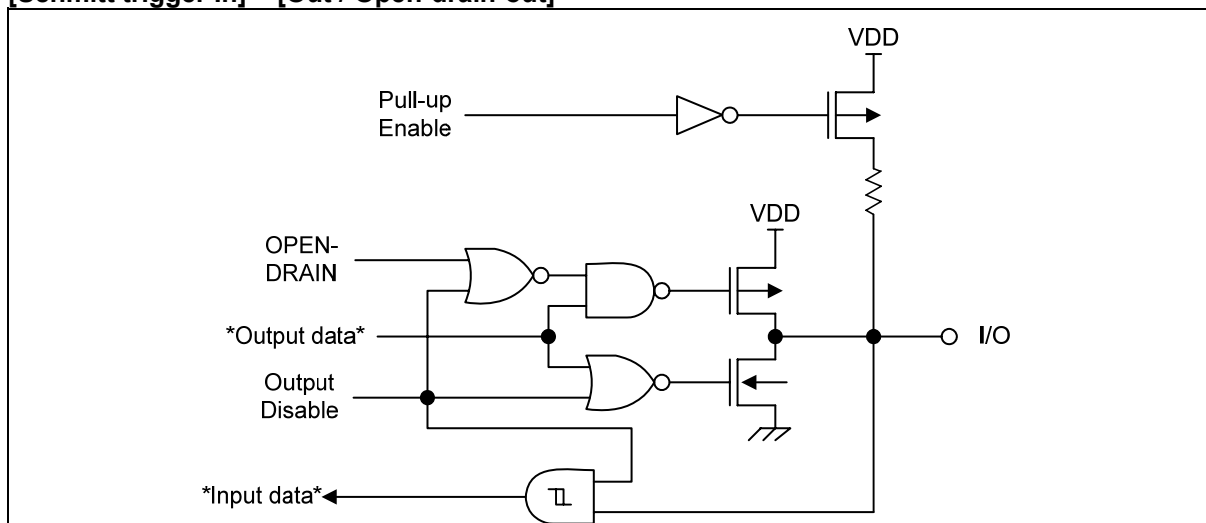

Input/Output data	Input data	Output data
R14	RxD	-
R15	-	TxD
R16	SDA	-
R17	-	SCL

[Input] + [Out / Open-drain-out] + [ADC]

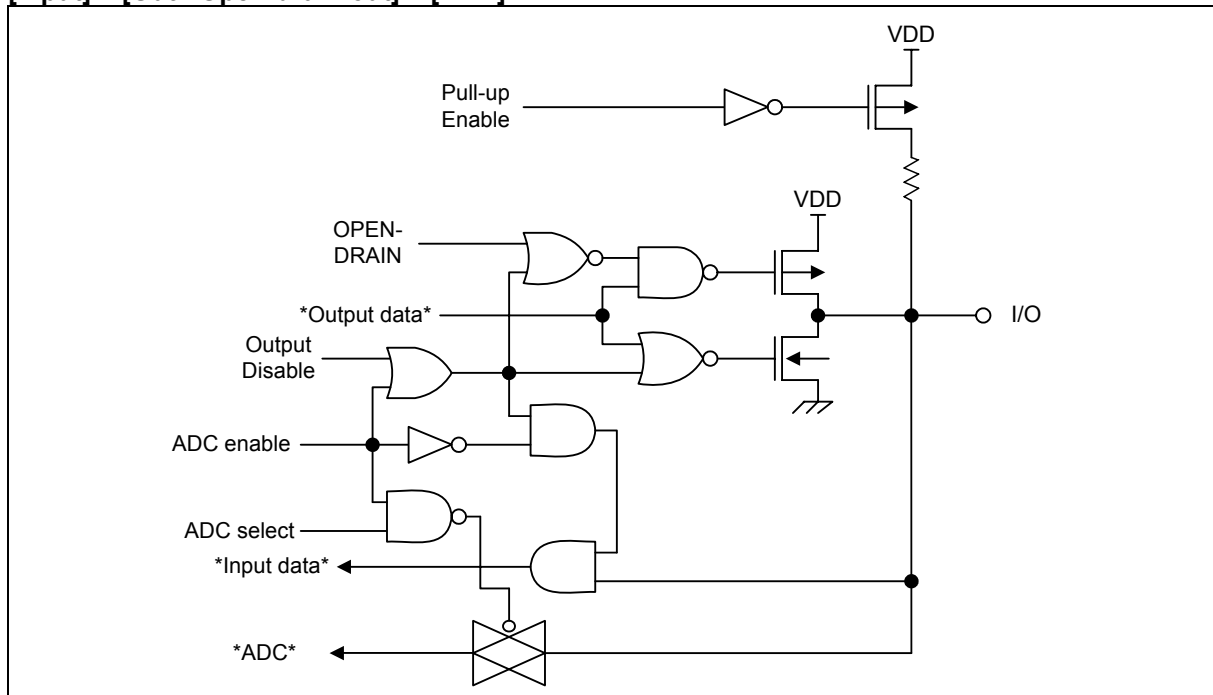

Input/Output data	Input data	Output data	ADC
R20	-	-	AN9
R25	-	-	AN10
R26	-	-	AN11
R27	-	-	AN12
R30	-	-	AN13
R31	-	-	AN14

[Input] + [Out/Open-drain out]

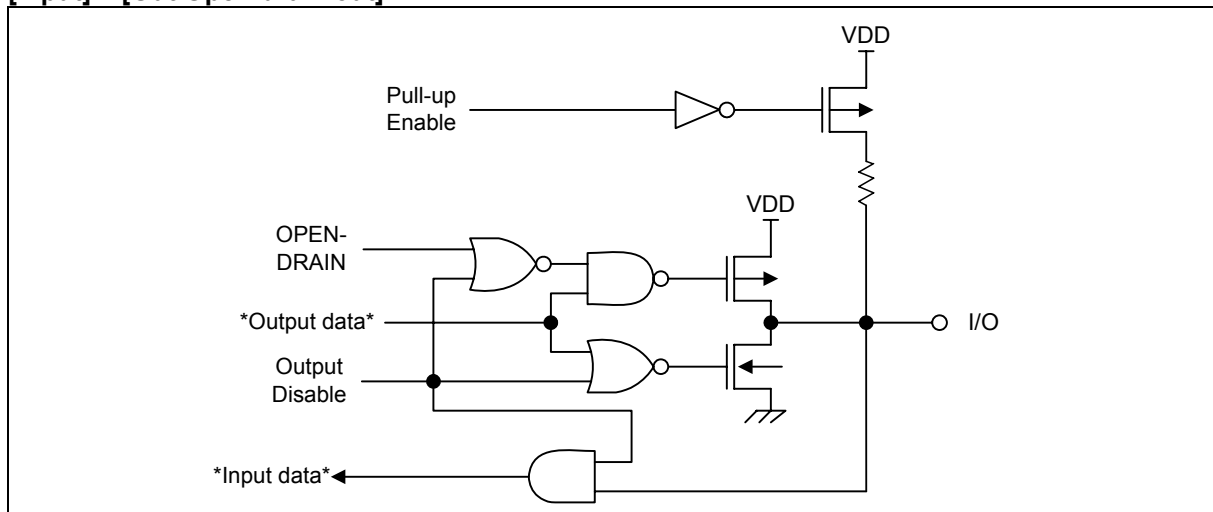

Input/Output data	Input/Output data	Input/Output data	Input/Output data
R21	R32	R40	R50
R22		R41	R51
R23		R42	R52
R24		R43	R53
		R44	
		R45	
		R46	
		R47	

[Schmitt trigger In] + [Open-drain-out] + [Reset]

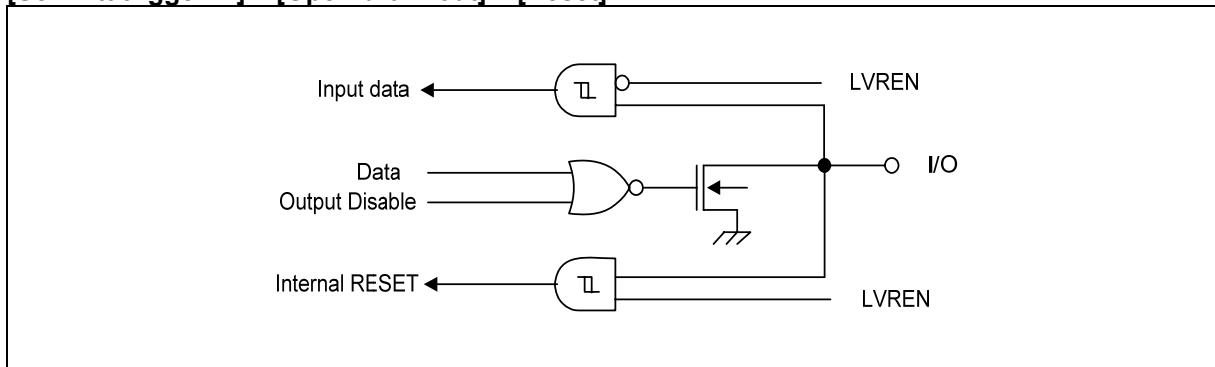

R35/RESETB

7. ELECTRICAL CHARACTERISTICS

7.1 Absolute Maximum Ratings

Parameter	Symbol	Ratings	Unit
Supply Voltage	VDD	-0.3 – +6.0	V
Normal Voltage Pin	VI	-0.3 – VDD+0.3	V
	VO	-0.3 – VDD+0.3	V
	IOH	-10	mA
	ΣIOH	-80	mA
	IOL	30	mA
	ΣIOL	160	mA
Total Power Dissipation	fXIN	600	mW
Storage Temperature	TSTG	-65 – +150	°C

NOTE: Stresses above those listed under “Absolute Maximum Ratings” may cause permanent damage to the device. This is a stress rating only and functional operation of the device at any other conditions above those indicated in the operational sections of this specification is not implied. Exposure to absolute maximum rating conditions for extended periods may affect device reliability.

7.2 RECOMMENDED OPERATING CONDITION

Parameter	Symbol	Conditions	Min	Typ	Max	Units
Operating Voltage	V _{DD}	f _{xin} = 1.0 – 4.2MHz	2.2	-	5.5	V
		f _{xin} = 1.0 – 8.0MHz	2.7	-	5.5	
		f _{xin} = 1.0 – 12.0MHz	4.0	-	5.5	
Operating Temperature	TOPR	V _{DD} = 2.2 – 5.5V	-40		85	°C

7.3 A/D CONVERTER CHARACTERISTICS

($T_A = -40\text{ }^\circ\text{C}$ to $+85\text{ }^\circ\text{C}$, $V_{ref} = 2.7\text{ V}$ to 5.5 V , $V_{SS}=0\text{V}$)

Parameter	Symbol	Conditions	Min	Typ	Max	Units
A/D converting Resolution	-	-	-	12	-	bits
Integral Linearity Error	ILE	Vref = 5.12V, V _{SS} = 0V, T _A = + 25 °C	-	-	± 3	LSB
Differential Linearity Error	DLE		-	-	± 2	
Offset Error of Top	EOT		-	±1	± 3	
Offset Error of Bottom	EOB		-	±1	± 3	
Overall Accuracy	-		-	±3	±5	
Conversion time	t _{CONV}	-	25	-	-	µs
Analog input voltage	V _{AIN}	-	V _{SS}	-	Vref	V
Analog Reference Voltage	A _{Vref}	-	2.7	-	5.5	V
Analog input current	I _{AIN}	VDD = Vref = 5V	-	-	10	µA
Analog block current	I _{AVDD}	VDD = Vref = 5V	-	1	3	mA
		VDD = Vref = 3V	-	0.5	1.5	
		VDD = Vref = 5V Power down mode	-	100	500	nA
BGR	-	VDD = 5v, T _A = + 25 °C	-	1.67	-	V
	-	VDD = 4v, T _A = + 25 °C	-	1.63	-	V
	-	VDD = 3v, T _A = + 25 °C	-	1.62	-	V

7.4 DC CHARACTERISTICS

($T_A = -40^\circ\text{C}$ to $+85^\circ\text{C}$, $V_{DD} = 2.2 - 5.5\text{V}$, $V_{SS}=0\text{V}$, $f_{XIN}=12\text{MHz}$)

Parameter	Symbol	Conditions	Min	Typ	Max	Units
Input High Voltage	VIH1	R0x, R1x, R33 – R35 $V_{DD} = 4.5\text{V} - 5.5\text{V}$	0.8VDD	–	VDD+0.3	V
	VIH2	All input pins except VIH1, VIH3, $V_{DD} = 4.5\text{V} - 5.5\text{V}$	0.7VDD	–	VDD+0.3	
	VIH3	Xin, Xout, SXin, SXout $V_{DD} = 4.5\text{V} - 5.5\text{V}$	0.8VDD	–	VDD+0.3	
Input Low Voltage	VIL1	R0x, R1x, R33 – R35 $V_{DD} = 4.5\text{V} - 5.5\text{V}$	– 0.3	–	0.2VDD	V
	VIL2	All input pins except VIH1, VIH3, $V_{DD} = 4.5\text{V} - 5.5\text{V}$	– 0.3	–	0.3VDD	
	VIL3	Xin, Xout, SXin, SXout $V_{DD} = 4.5\text{V} - 5.5\text{V}$	– 0.3	–	0.2VDD	
Output High Voltage	VOH1	All output ports except VOL2, $I_{OH} = -2\text{mA}$ $V_{DD} = 4.5\text{V} - 5.5\text{V}$	VDD–1.0	–	–	V
	VOH2	R4x, R5x $I_{OH} = -10\text{mA}$ $V_{DD} = 4.5\text{V} - 5.5\text{V}$	VDD–2.0	VDD–1.5	–	
Output Low Voltage	VOL1	All output ports except VOL2, $I_{OL}=15\text{mA}$ $V_{DD} = 4.5\text{V} - 5.5\text{V}$	–	–	2.0	V
	VOL2	R4x, R5x $I_{OL}=60\text{mA}$ $V_{DD} = 4.5\text{V} - 5.5\text{V}$	–	1.5	2.0	
Input high leakage current	IIH	R0x – R5x, $V_{in}=V_{DD}$	–	–	1	uA
Input low leakage current	IIL	R0x – R5x, $V_{in}=V_{SS}$	- 1	–	–	uA
Pull-up resistor	RPU	$V_I=0\text{V}$, $T_A=25^\circ\text{C}$, R0x – R5x except R35 $V_{DD}=5\text{V}$	25	50	100	k Ω
		$V_I=0\text{V}$, $T_A=25^\circ\text{C}$, R0x – R5x except R35 $V_{DD}=3\text{V}$	50	100	200	

7.5 DC CHARACTERISTICS(continued)

($T_A = -40\text{ }^{\circ}\text{C}$ to $+85\text{ }^{\circ}\text{C}$, $V_{DD} = 2.2 - 5.5\text{V}$, $V_{SS}=0\text{V}$, $f_{XIN}=12\text{MHz}$)

Parameter	Symbol	Conditions	Min	Typ	Max	Units
OSC feedback resistor	RX1	Xin=VDD, Xout=VSS TA=25 C, VDD=5V	350	700	1500	MΩ
	RX2	SXin=VDD, SXout=VSS TA=25 C, VDD=5V	1800	3600	5400	
Supply current	IDD1	Active mode, fx=12MHz, VDD=5V±10% Crystal oscillator	–	8.0	15.0	mA
		fx=8MHz, VDD=3V±10%	–	3.0	6.0	
	ISLEEP1	Sleep mode, fx=12MHz, VDD=5V±10% Crystal oscillator	–	2.0	4.0	mA
		fx=8MHz, VDD=3V±10%	–	1.0	2.0	
	IDD2	Active mode, fx=32.768kHz, VDD=3V±10% Crystal oscillator, TA=25°C	–	150.0	300.0	uA
	ISLEEP2	Sleep mode, fx=32.768kHz, VDD=3V±10% Crystal oscillator, TA=25°C	–	6.0	12.0	uA
	ISTOP	Stop mode VDD=5.5V, TA=25°C	–	0.5	5.0	uA
POR level			1.82		2.1	v

7.6 Input/output Capacitance

($T_A = -40\text{ }^{\circ}\text{C}$ to $+85\text{ }^{\circ}\text{C}$, $V_{DD} = 0\text{V}$)

Parameter	Symbol	Conditions	Min	Typ	Max	Units
Input Capacitance	CIN	f=1MHz Unmeasured pins are connected Vss	–	–	10	pF
Output Capacitance	COUT					
I/O Capacitance	CIO					

7.7 Serial I/O Characteristics

($T_A = -40\text{ }^\circ\text{C}$ to $+85\text{ }^\circ\text{C}$, $V_{DD} = 2.2\text{ V}$ to 5.5 V)

Parameter	Symbol	Conditions	Min	Typ	Max	Units
SCK cycle time	t_{KCY}	External SCK source	1,000			nS
		Internal SCK source	1,000			
SCK high, low width	t_{KH}, t_{KL}	External SCK source	500	-	-	nS
		Internal SCK source	$t_{KCY}/2-50$			
SI setup time to SCK high	t_{SIK}	External SCK source	250			nS
		Internal SCK source	250			
SI hold time to SCK High	t_{KSI}	External SCK source	400			nS
		Internal SCK source	400			
Output delay for SCK to SOUT	t_{KSO}	External SCK source	-	-	300	nS
		Internal SCK source			250	
Interrupt input, high, low width	t_{INTH}, t_{INTL}	All interrupt, $V_{DD} = 5\text{ V}$	200	-	-	nS
RESETB input low width	t_{RSL}	Input, $V_{DD} = 5\text{ V}$	10	-	-	uS

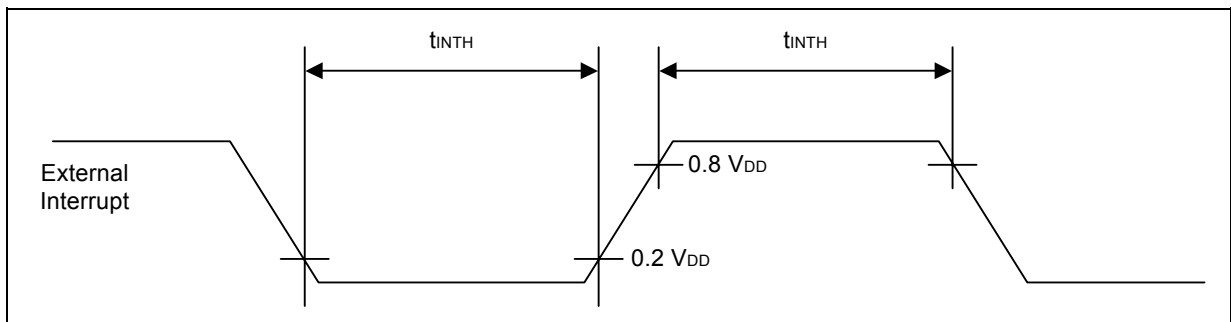

Figure 7-1 Input Timing for External Interrupts

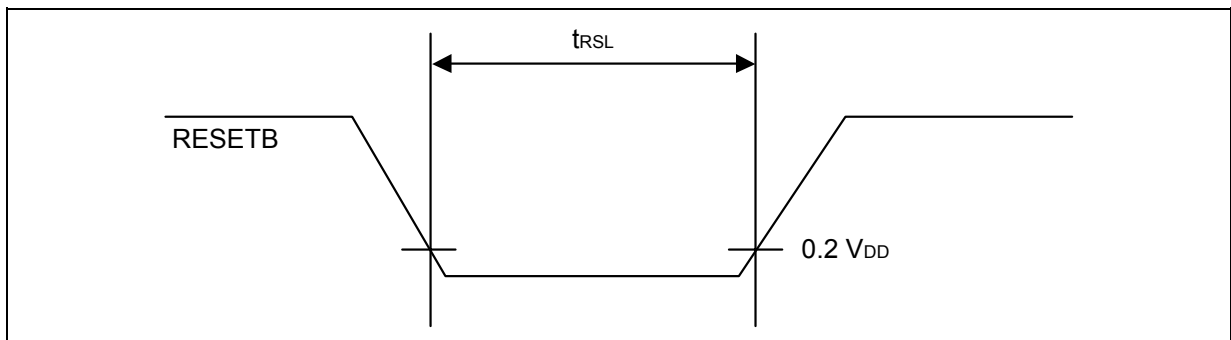

Figure 7-2 Input Timing for RESETB

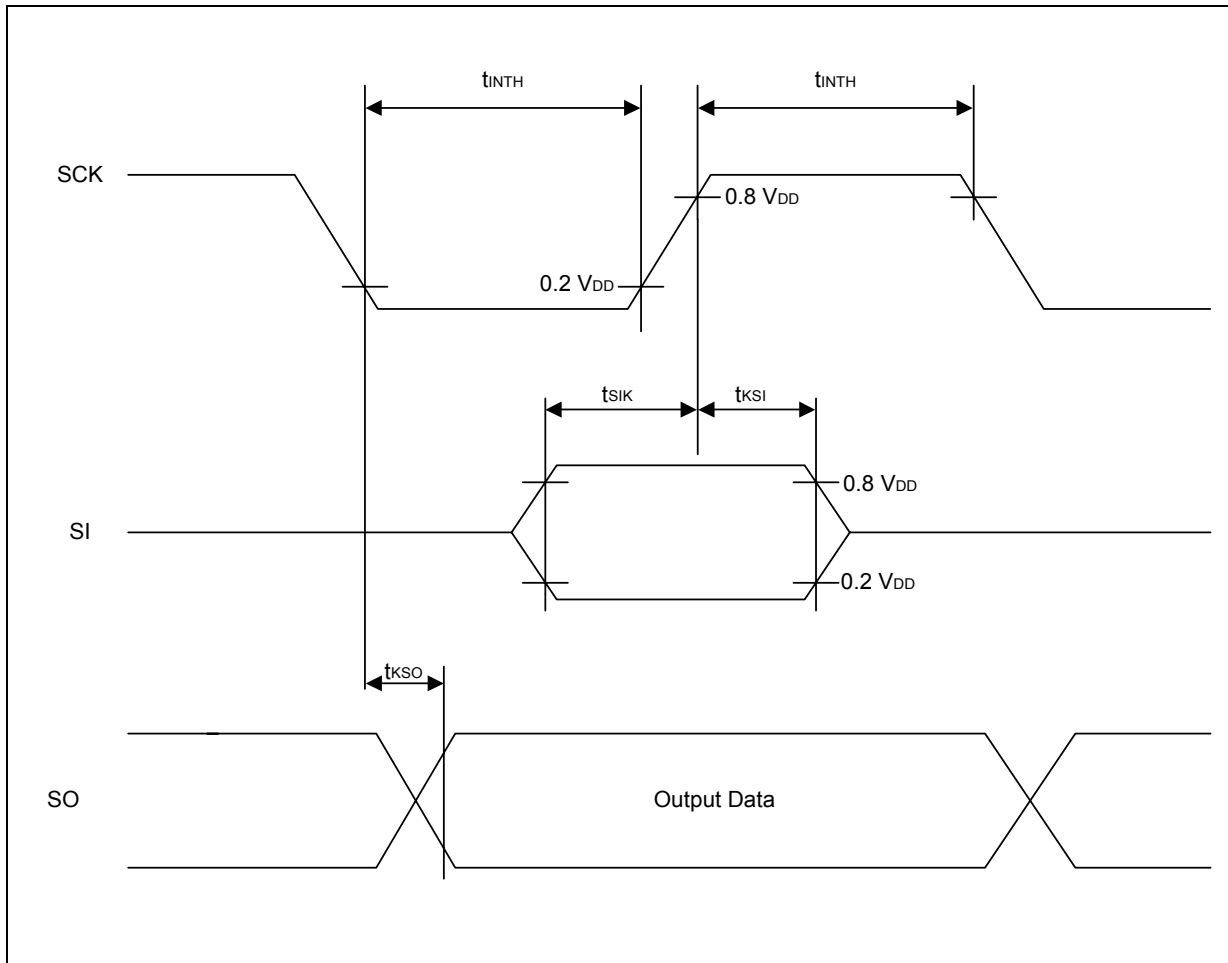

Figure 7-3 Serial Interface Data Transfer Timing

7.8 Data Retention Voltage in Stop Mode

($T_A = -40\text{ }^\circ\text{C}$ to $+85\text{ }^\circ\text{C}$, $V_{DD} = 2.2\text{ V}$ to 5.5 V)

Parameter	Symbol	Conditions	Min	Typ	Max	Units
Data retention supply voltage	VDDDR	–	2.2	–	5.5	V
Data retention supply current	IDDDR	$V_{DDDR} = 2.2\text{ V}$ ($T_A = 25\text{ }^\circ\text{C}$), Stop mode	–	–	1	μA

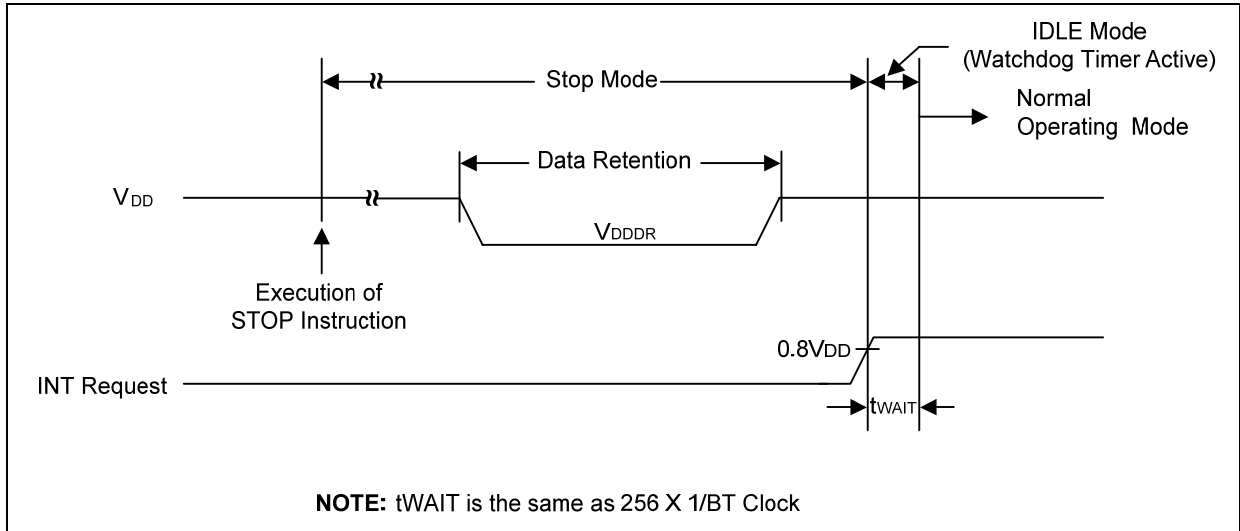

Figure 7-4 Stop Mode Release Timing When Initiated by an Interrupt

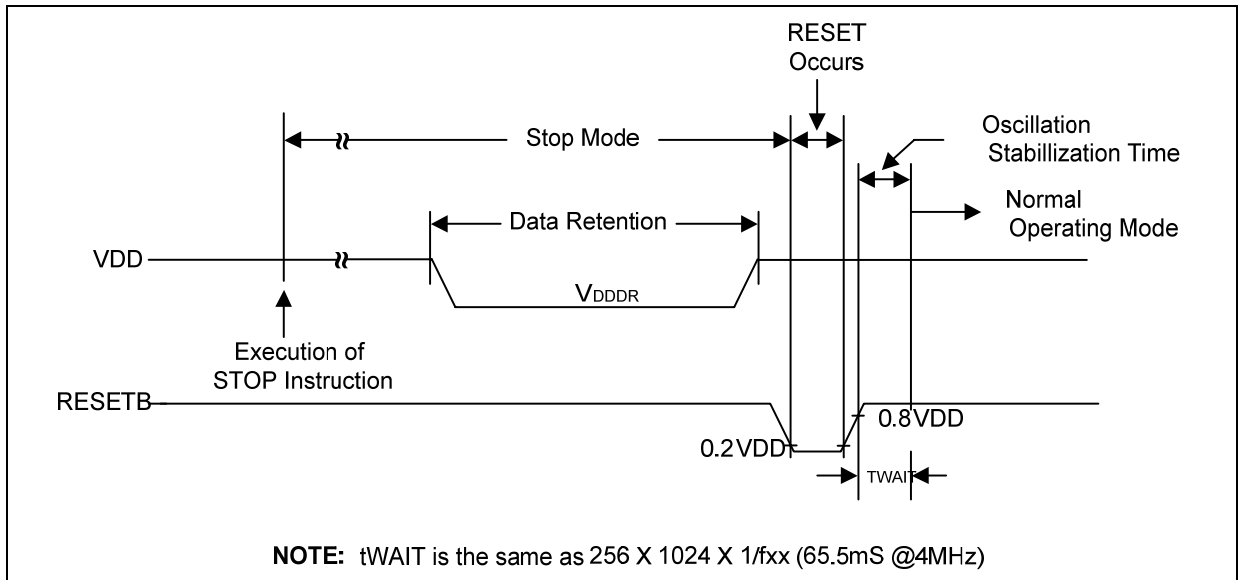

Figure 7-5 Stop Mode Release Timing When Initiated by RESETB

7.9 LVR (Low Voltage Reset) Electrical Characteristics

($T_A = -40\text{ }^\circ\text{C}$ to $+85\text{ }^\circ\text{C}$, $V_{DD} = 2.2\text{ V}$ to 5.5 V)

Parameter	Symbol	Conditions	Min	Typ	Max	Units
LVR voltage	VLVR	-	2.2	2.4	2.6	V
			2.5	2.7	2.9	
			2.7	3.0	3.3	
			3.6	4.0	4.4	
Hysteresis voltage of LVR	ΔV	-	-	10	100	mV
Current consumption	ILVR	$V_{DD} = 3\text{ V}$	-	45	80	μA

Note The current of LVR circuit is consumed when LVR is enabled by "ROM Option".
 $\cdot 2^{16}/f_x$ (= 6.55 ms at $f_x = 10\text{ MHz}$)

7.10 POR (Power on Reset) Electrical Characteristics

($T_A = -40\text{ }^\circ\text{C}$ to $+85\text{ }^\circ\text{C}$, $V_{DD} = 2.2\text{ V}$ to 5.5 V)

Parameter	Symbol	Conditions	Min	Typ	Max	Units
POR voltage	VPOR	-	1.4	1.7	2.0	V
VDD Voltage Rising Time	tR	-	0.05	-	16.7	V/mS
Current consumption	IPOR	$V_{DD} = 3\text{ V}$	-	45	80	μA

7.11 UART Timing Characteristics

($T_A = -40\text{ }^\circ\text{C}$ to $+85\text{ }^\circ\text{C}$, $V_{DD} = 2.2\text{ V}$ to 5.5 V)

Parameter	Symbol	Min	Typ	Max	Units
Serial port clock cycle time	t_{SCK}	1250	$t_{CPU} \times 16$	1650	nS
Output data setup to clock rising edge	t_{S1}	590	$t_{CPU} \times 13$	-	
Clock rising edge to input data valid	t_{S2}	-	-	590	
Output data hold after clock rising edge	t_{H1}	$t_{CPU} - 50$	t_{CPU}	-	
Input data hold after clock rising edge	t_{H2}	0	-	-	

Serial port clock High, Low level width	t_{HIGH}, t_{LOW}	470	$t_{CPU} \times 8$	970	
---	---------------------	-----	--------------------	-----	--

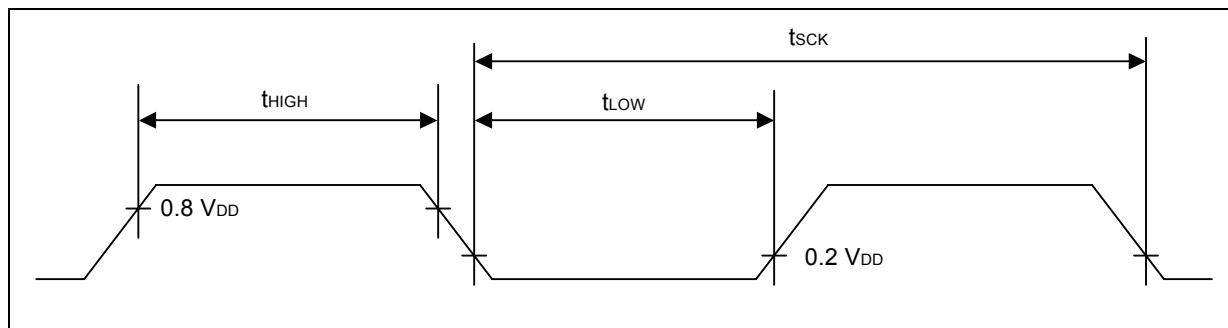

Figure 7-6 Waveform for UART Timing Characteristics

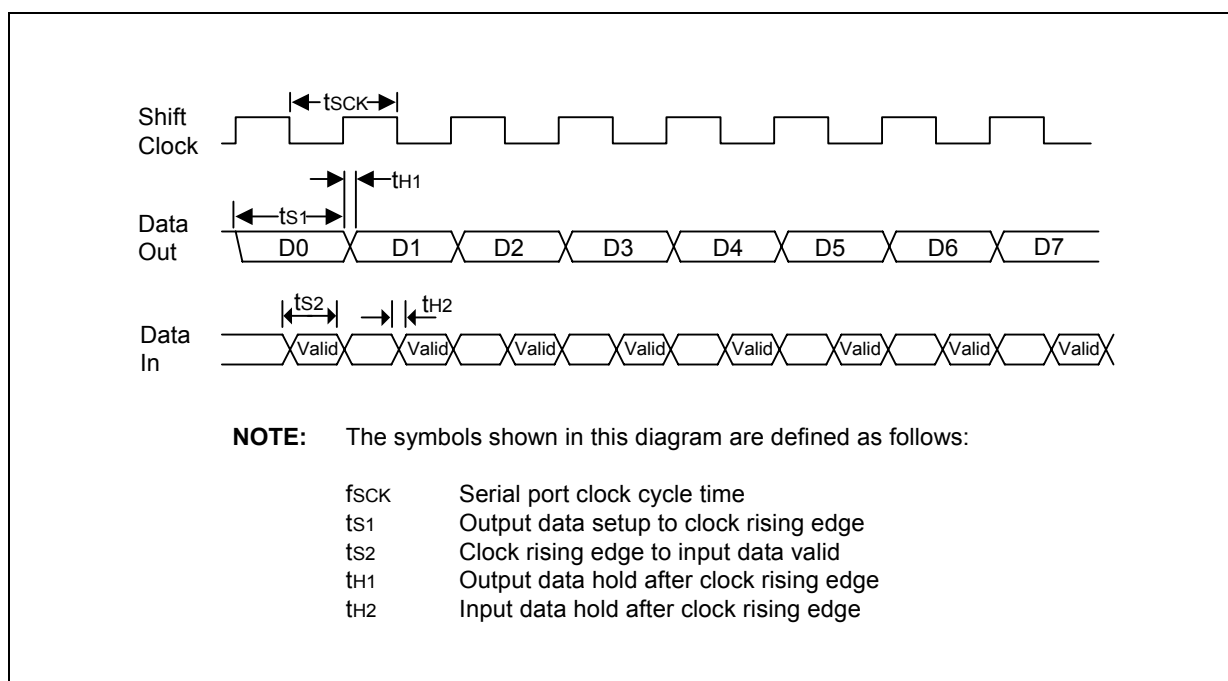

Figure 7-7 Timing Waveform for the UART Module

7.12 IIC Timing Characteristics

($T_A = -40\text{ }^\circ\text{C}$ to $+85\text{ }^\circ\text{C}$, $V_{DD} = 2.2\text{ V}$ to 5.5 V)

Parameter	Condition	Symbol	Min	Typ.	Max	Units
SCL clock frequency	–	t_{SCL}	–	–	100(std.) 400(fast)	kHz
SCL high level pulse width	SCL clock = 100kHz	$t_{SCLHIGH}$	4.0	–	–	us
SCL low level pulse width		t_{SCLLOW}	4.7	–	–	us
BUS free time		t_{BUF}	4.7	–	–	us
Start hold time		t_{START}	4.0	–	–	us
Stop setup time		t_{STOP}	4.0	–	–	us
Data hold time		t_{DAH}	0	–	–	us
Data setup time		t_{DAS}	0.25	–	–	us

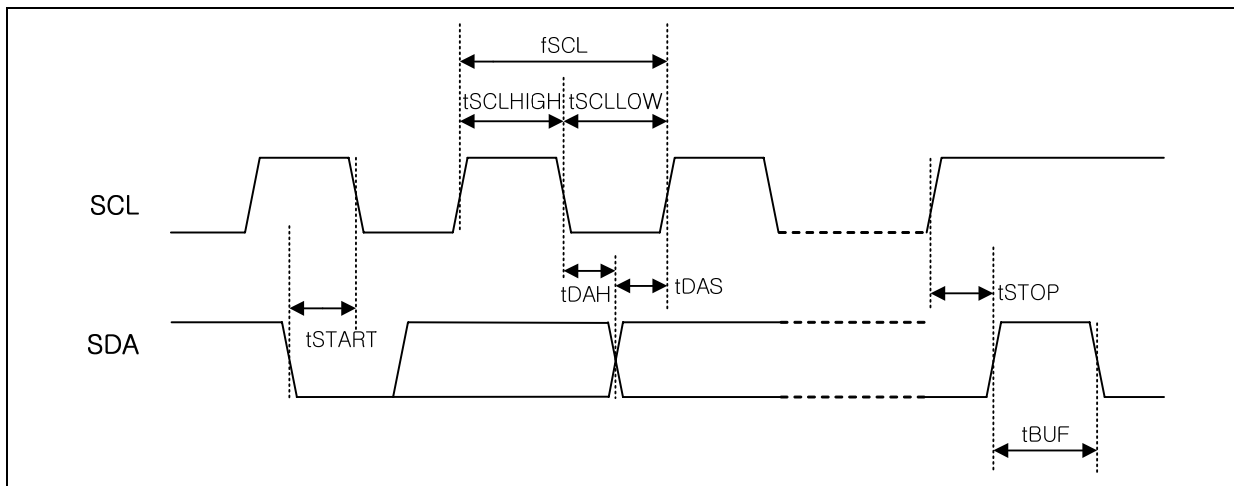

Figure 7-8 Waveform for IIC Timing Characteristics

7.13 Main clock Oscillator Characteristics

($T_A = -40^{\circ}\text{C}$ to $+85^{\circ}\text{C}$, $V_{DD} = 2.2\text{ V}$ to 5.5 V)

Oscillator	Parameter	Conditions	Min	Typ.	Max	Units
Crystal	Main oscillation frequency	2.2 V – 5.5 V	1.0	–	4.2	MHz
		2.7 V – 5.5 V	1.0	–	8.0	
		4.0 V – 5.5 V	1.0	–	12.0	
Ceramic Oscillator	Main oscillation frequency	2.2 V – 5.5 V	1.0	–	4.2	MHz
		2.7 V – 5.5 V	1.0	–	8.0	
		4.0 V – 5.5 V	1.0	–	12.0	
External Clock	X_{IN} input frequency	2.2 V – 5.5 V	1.0	–	4.2	MHz
		2.7 V – 5.5 V	1.0	–	8.0	
		4.0 V – 5.5 V	1.0	–	12.0	

7.14 External RC Oscillation Characteristics

($T_A = -40^{\circ}\text{C}$ to $+85^{\circ}\text{C}$, $V_{DD} = 2.2\text{ V}$ to 5.0 V)

Parameter	Symbol	Conditions	Min	Typ.	Max	Units
RC oscillator frequency Range ⁽¹⁾	f _{ERC}	$T_A = 25^{\circ}\text{C}$	1	–	8	MHz
Accuracy of RC Oscillation ⁽²⁾	ACCERC	$V_{DD} = 5.0\text{V}$, $T_A = 25^{\circ}\text{C}$	–6	–	+6	%
		$V_{DD} = 5.0\text{V}$, $T_A = -40^{\circ}\text{C}$ to $+85^{\circ}\text{C}$	–12	–	+12	
RC oscillator setup time ⁽³⁾	t _{SUERC}	$T_A = 25^{\circ}\text{C}$	–	–	10	mS

- Note:**
- The external resistor is connected between V_{DD} and X_{IN} pin and the 270pF capacitor is connected between X_{IN} and V_{SS} pin. (X_{OUT} pin can be used as a normal port). The frequency is adjusted by external resistor.
 - The min/max frequencies are within the range of RC OSC frequency (1MHz to 8MHz)
 - Data based on characterization results, not tested in production

7.15 Internal RC Oscillation Characteristics

($T_A = -40\text{ }^\circ\text{C}$ to $+85\text{ }^\circ\text{C}$, $V_{DD} = 2.2\text{ V}$ to 5.0 V)

Parameter	Symbol	Conditions	Min	Typ.	Max	Units
RC oscillator frequency (1)	fIRC	$V_{DD} = 5.0\text{V}$, $T_A = 25\text{ }^\circ\text{C}$	-4%	8.0	4%	MHz
		$V_{DD} = 5.0\text{V}$, $T_A = -40\text{ }^\circ\text{C}$ to $+85\text{ }^\circ\text{C}$	-20%	8.0	20%	
Clock duty ratio	TOD	–	40	50	60	%
RC oscillator setup time (2)	tSUIRC	$T_A = 25\text{ }^\circ\text{C}$	–	–	10	mS

- 1. Data based on characterization results, not tested in production
- 2. X_{IN} and X_{OUT} pins can be used as I/O ports.

7.16 Sub clock Oscillator Characteristics

($T_A = -40\text{ }^\circ\text{C}$ to $+85\text{ }^\circ\text{C}$, $V_{DD} = 2.2\text{ V}$ to 5.5 V)

Oscillator	Parameter	Conditions	Min	Typ.	Max	Units
Crystal	Sub oscillation frequency	2.2 V – 5.5 V	32	32.768	35	KHz
External Clock	SX _{IN} input frequency	2.2 V – 5.5 V	32	–	100	KHz

7.17 Main Oscillation Stabilization Time

($T_A = -40\text{ }^\circ\text{C}$ to $+85\text{ }^\circ\text{C}$, $V_{DD} = 2.2\text{ V}$ to 5.5 V)

Oscillator	Conditions	Min	Typ.	Max	Units
Crystal	$f_x > 1\text{ MHz}$	–	–	60	mS
Ceramic	Oscillation stabilization occurs when V_{DD} is equal to the minimum oscillator voltage range.	–	–	10	mS
External Clock	X _{IN} input high and low width (t _{XH} , t _{XL})	40.0	–	480	nS

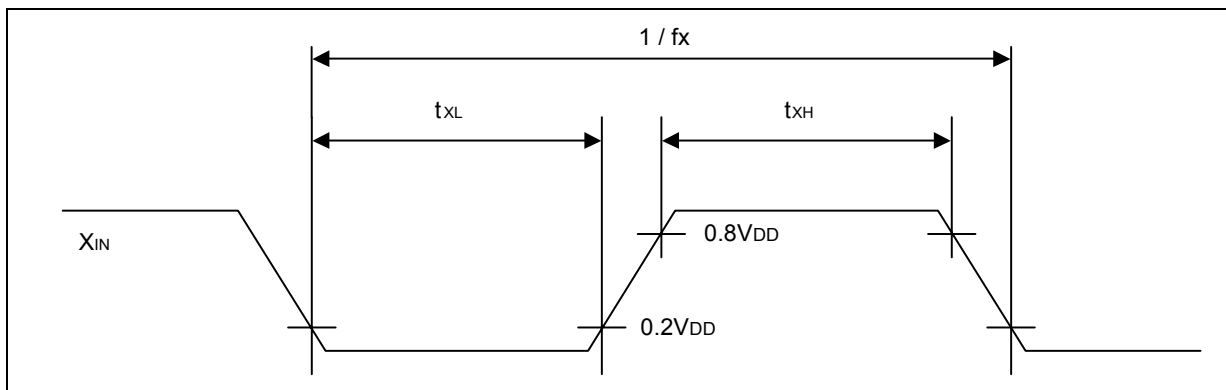

Figure 7-9 Clock Timing Measurement at XIN

7.18 Sub Oscillation Stabilization Time

(T_A = - 40 °C to + 85°C, V_{DD} = 2.2 V to 5.5 V)

Oscillator	Conditions	Min	Typ.	Max	Units
Crystal	–	–	–	10	S
External Clock	SX _{IN} input high and low width (t _{sxH} , t _{sxL})	5	–	15	uS

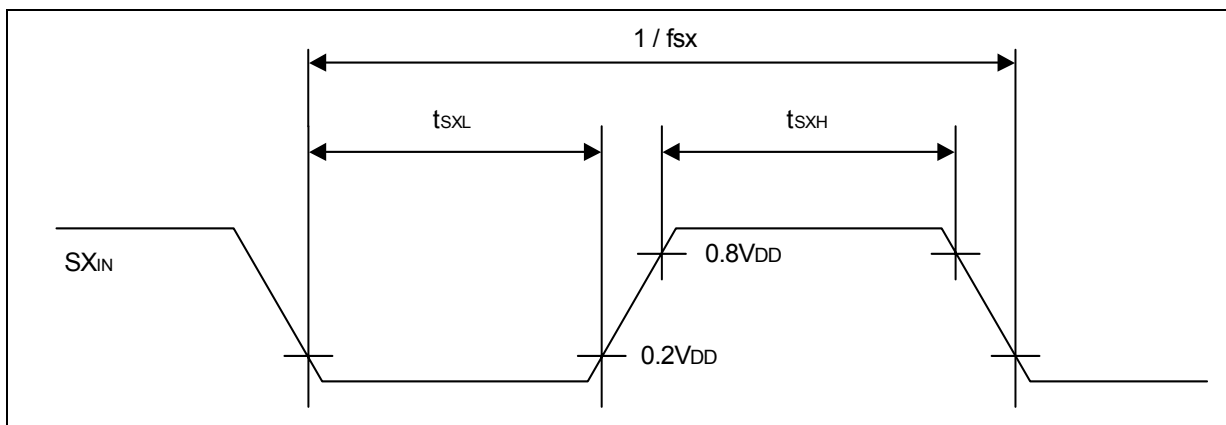

Figure 7-10 Clock Timing Measurement at SXIN

7.19 Operating Voltage Range

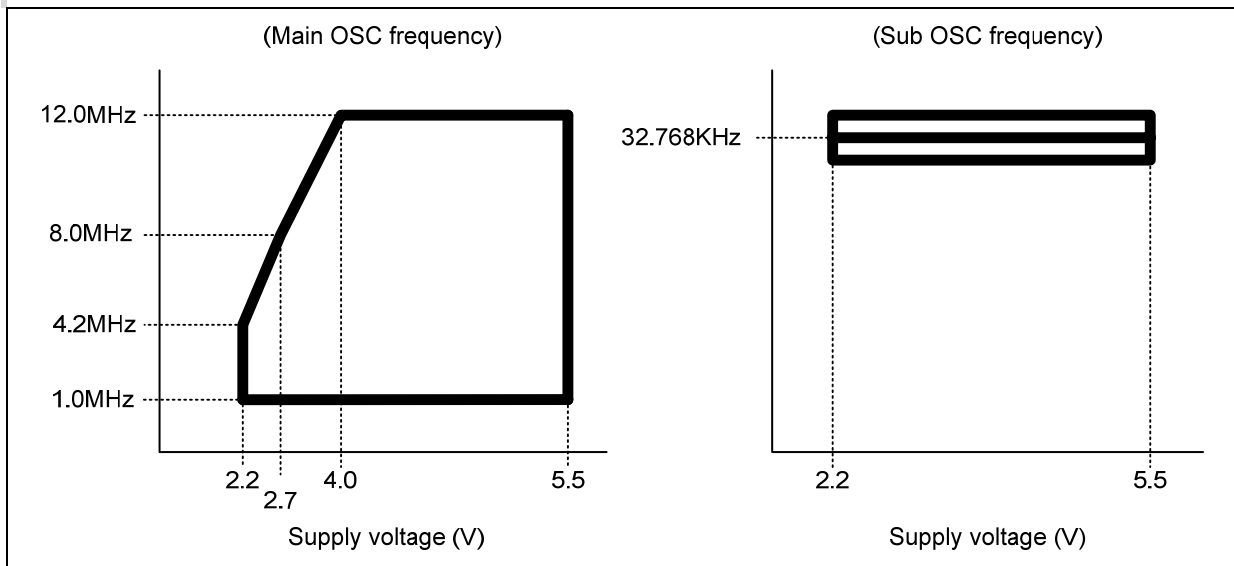

Figure 7-11 Operating Voltage Range

7.20 Typical Characteristics

These graphs and tables provided in this section are for design guidance only and are not tested or guaranteed. In some graphs or tables the data presented are outside specified operating range (e.g. outside specified VDD range). This is for information only and devices are guaranteed to operate properly only within the specified range.

The data presented in this section is a statistical summary of data collected on units from different lots over a period of time. “Typical” represents the mean of the distribution while “max” or “min” represents (mean + 3σ) and (mean - 3σ) respectively where σ is standard deviation.

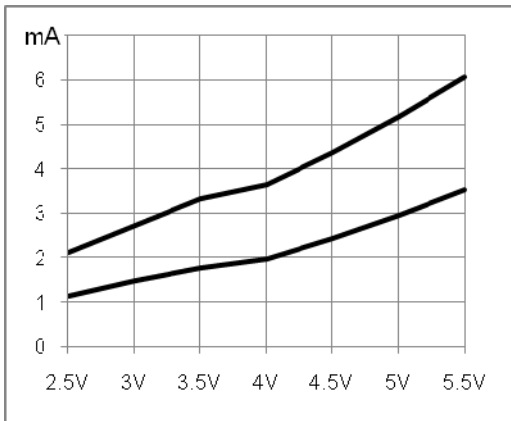

Figure 7-12 $I_{DD} - V_{DD}$ in Normal Mode

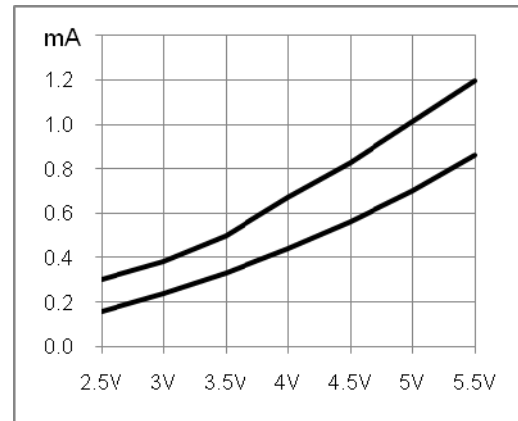

Figure 7-13 $I_{SLEEP} - V_{DD}$ in Sleep Mode

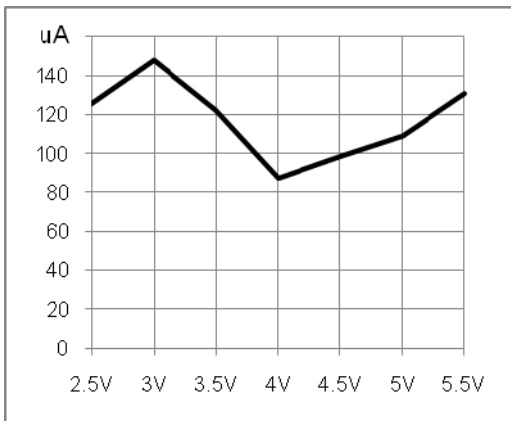

Figure 7-14 $I_{DD2} - V_{DD}$ in Sub Active Mode

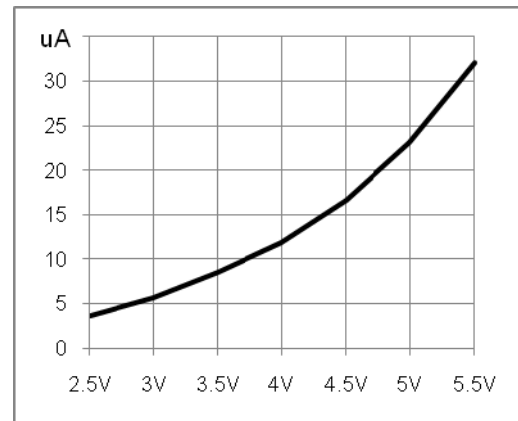

Figure 7-15 $I_{SLEEP2} - V_{DD}$ with Sub Clock

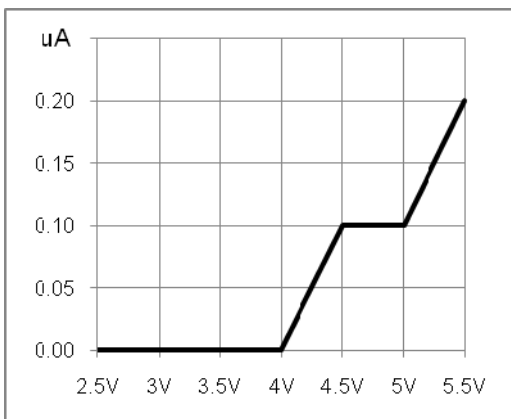

Figure 7-16 $I_{STOP} - V_{DD}$ in STOP Mode

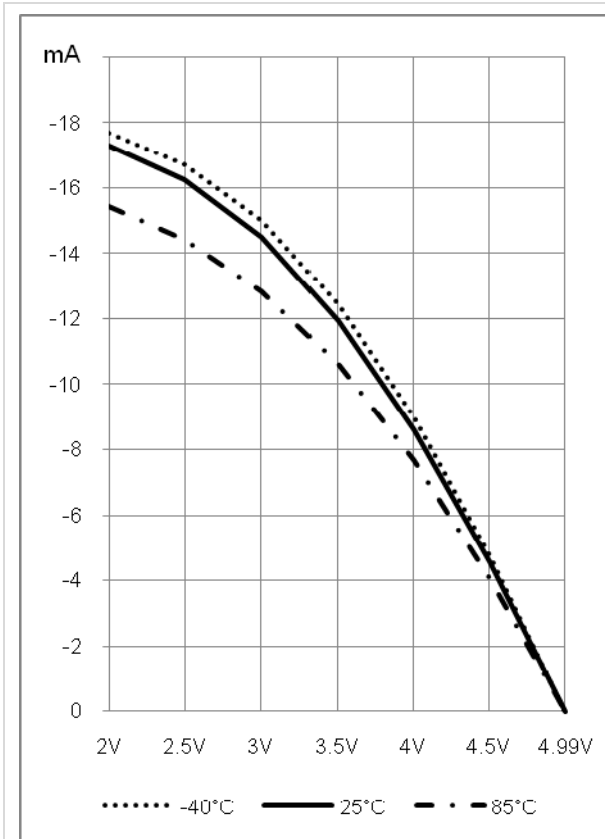

Figure 7-17 $I_{OH1} - V_{OH1}$ at $V_{DD}=5V$

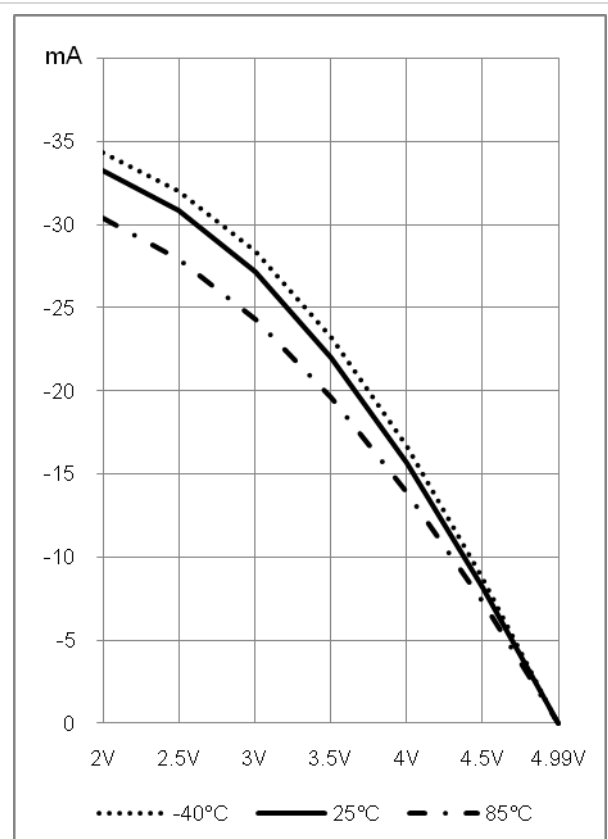

Figure 7-18 $I_{OH2} - V_{OH2}$ at $V_{DD}=5V$

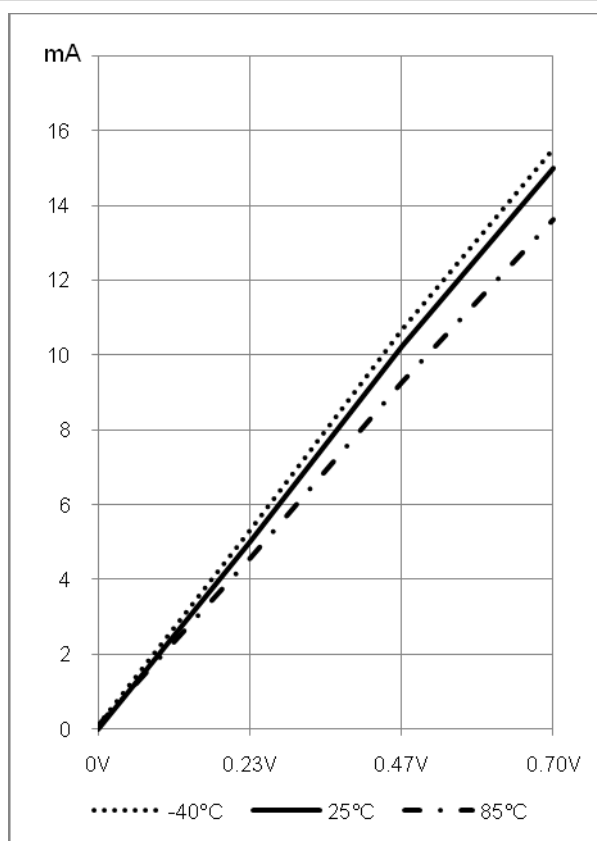

Figure 7-19 I_{OL1} - V_{OL1} at V_{DD}=5v

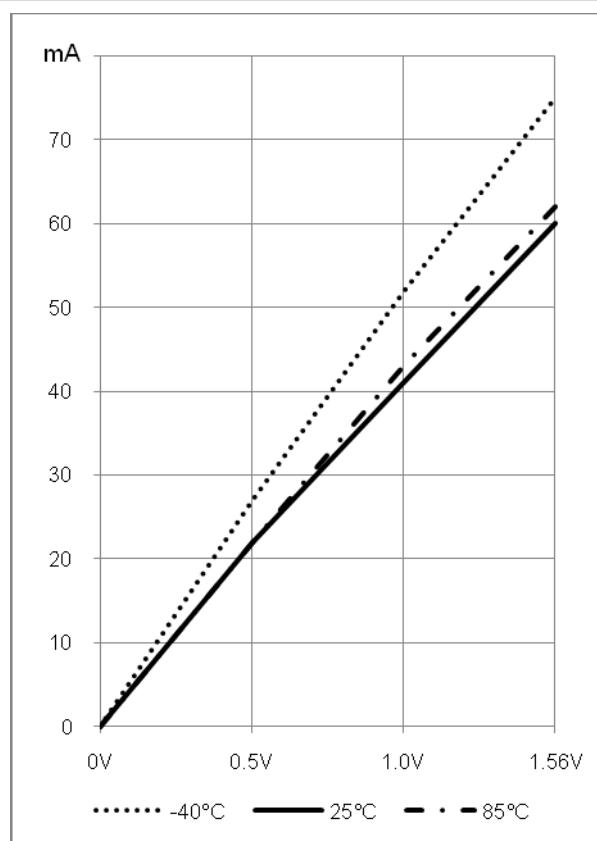

Figure 7-20 I_{OL2} - V_{OL2} at V_{DD}=5v

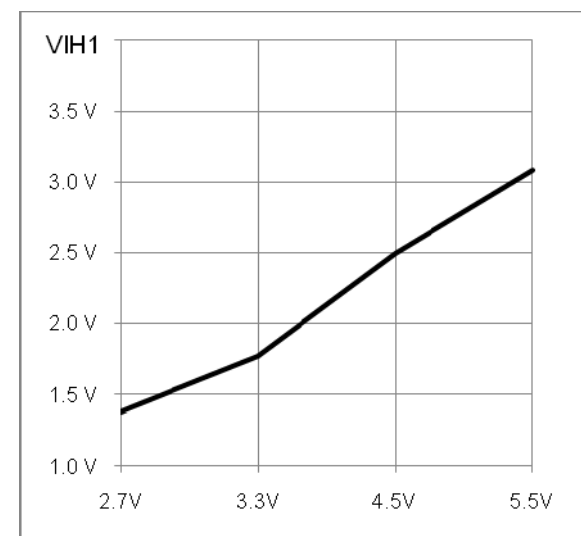

Figure 7-21 V_{IH1} - V_{DD}

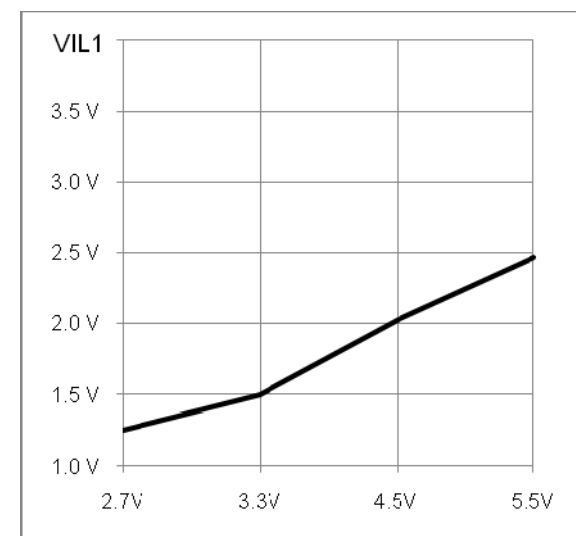

Figure 7-22 V_{IL1} - V_{DD}

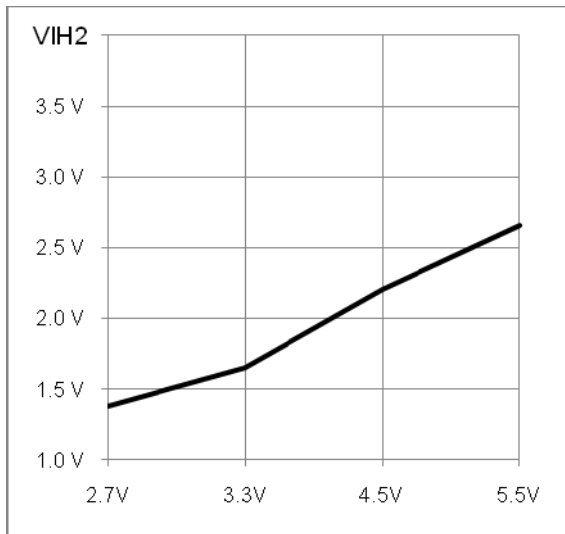

Figure 7-23 $V_{IH2} - V_{DD}$

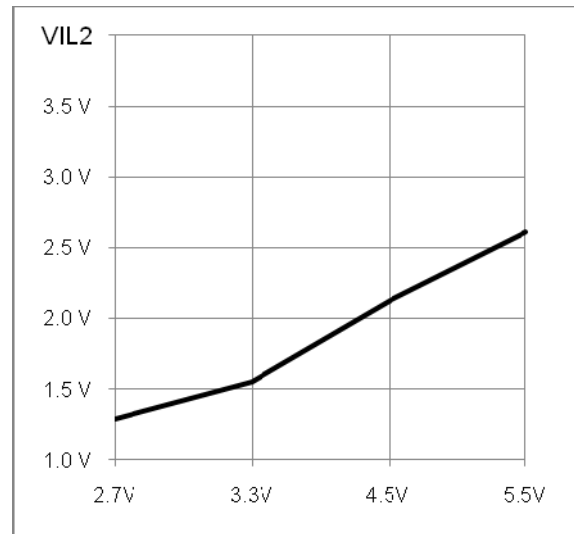

Figure 7-24 $V_{IL2} - V_{DD}$

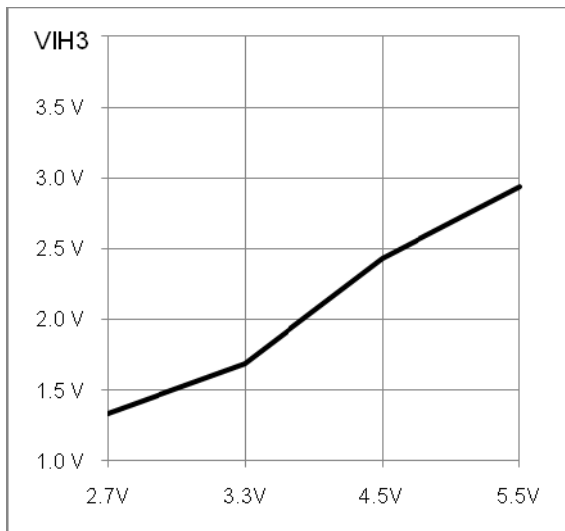

Figure 7-25 $V_{IH3} - V_{DD}$

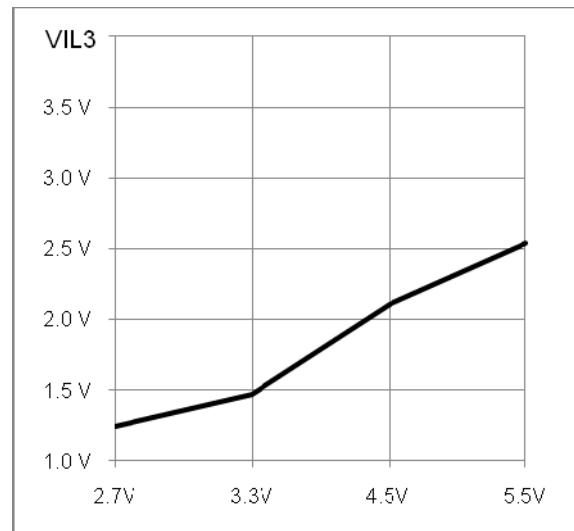

Figure 7-26 $V_{IL3} - V_{DD}$

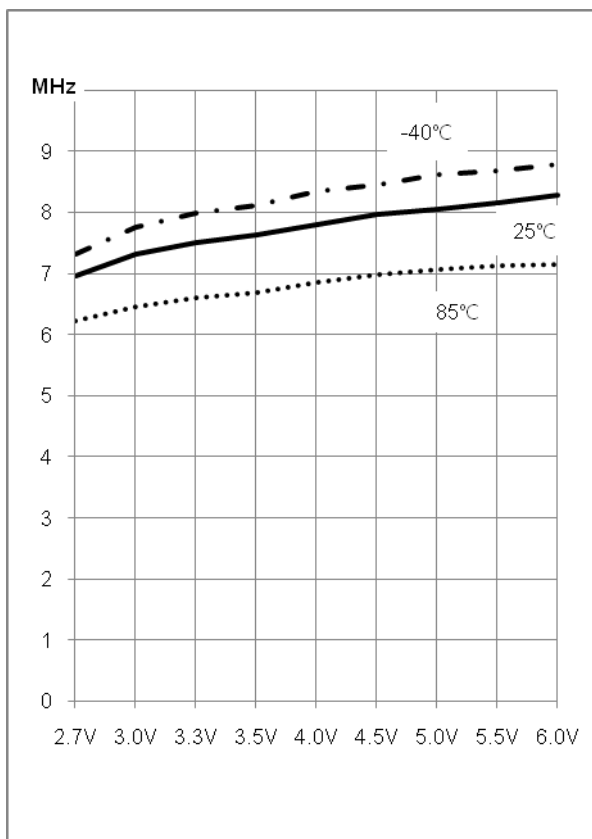

Figure 7-27 8MHz Internal OSC Freq. - V_{DD}

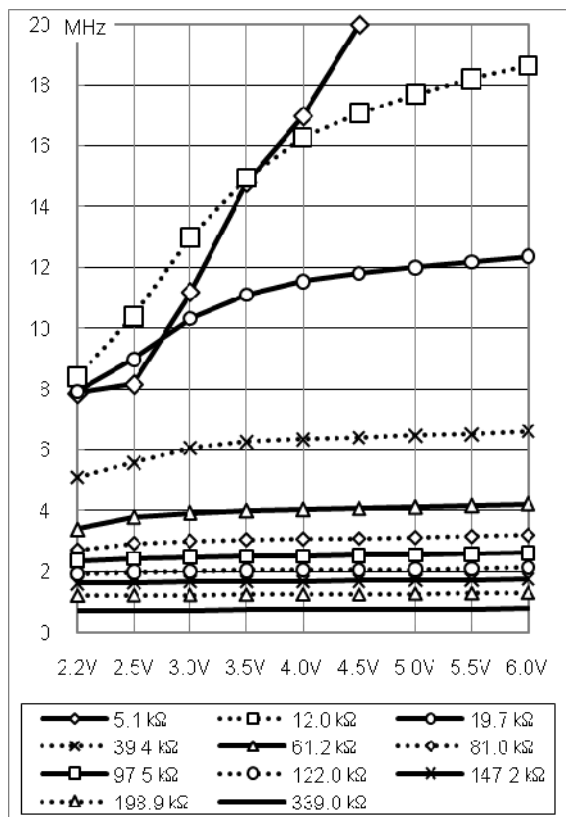

Figure 7-28 Ext. R/C OSC Freq. - V_{DD} at 25°C

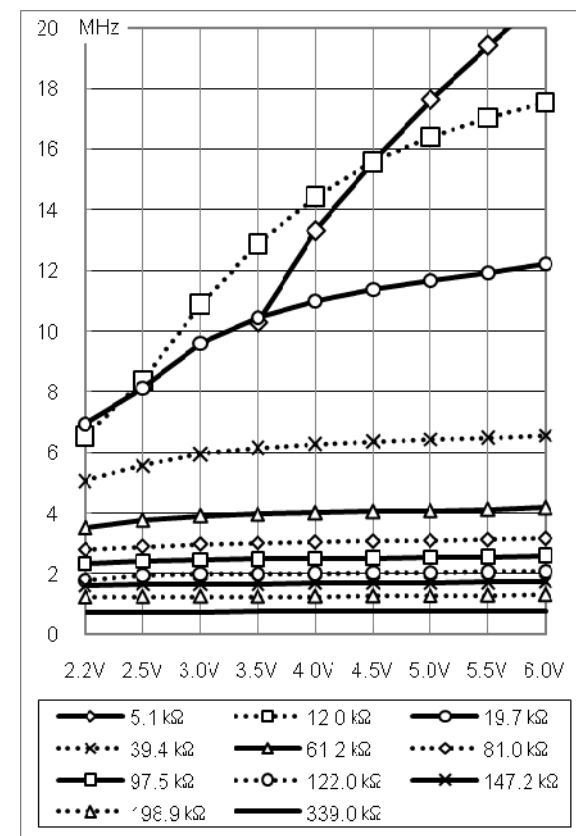

Figure 7-29 Ext. R/C OSC Freq. - V_{DD} at 85°C

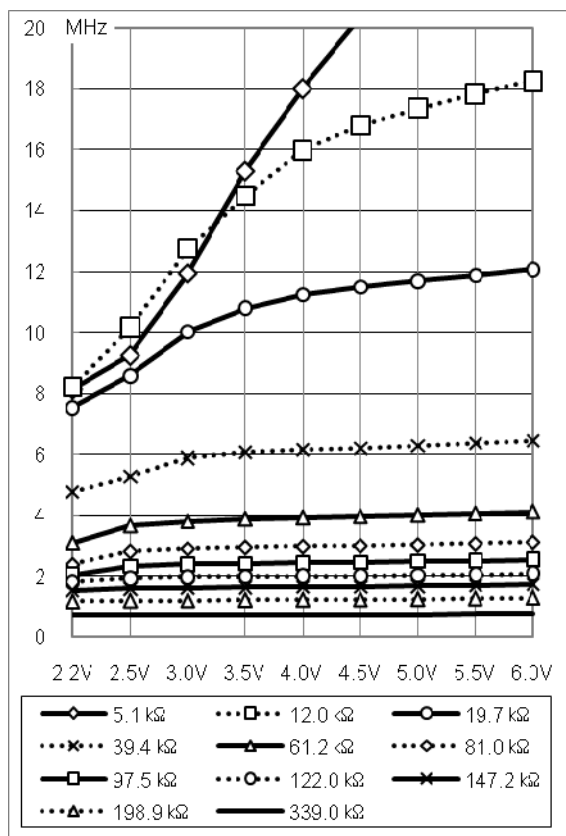
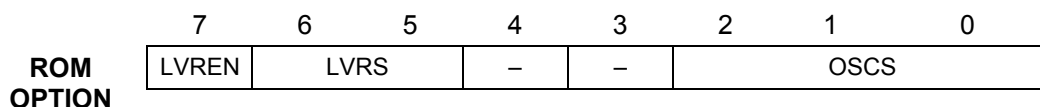

Figure 7-30 Ext. R/C OSC Freq. - V_{DD} at -40°C

8. ROM OPTION

The ROM Option is a start-condition byte of the chip. The default ROM Option value is 00H (LVR enable and External RC is selected). It can be changed by appropriate writing tools such as PGMPlusUSB, ISP, etc.

8.1 Rom Option



LVREN	LVR Enable/Disable bit	0: Enable (R35) 1: Disable (RESETB)
LVRS	LVR Level Selection bits	00: 2.4V 01: 2.7V 10: 3.0V 11: 4.0V
-	bit4 – bit3	Not used MC81F4x16
OSCS	Oscillator Selection bits	000: External RC 001: Internal RC; 4MHz 010: Internal RC; 2MHz 011: Internal RC; 1MHz 100: Internal RC; 8MHz 101: Not available (Note 4) 110: Not available (Note 5) 111: Crystal/ceramic oscillator

- Note:
1. When LVR is enabled, LVR level should be set to appropriate value, not default value.
 2. When you select the Crystal/ceramic oscillator, R33 and R34 pins are automatically selected for XIN and XOUT mode.
 3. When you select the external RC, R34 pin is automatically selected for XIN mode.
 4. If OSCS is set by '101', Oscillator works as 'Internal RC; 4MHz' mode.
 5. If OSCS is set by '110', Oscillator works as 'Internal RC; 2MHz' mode.

8.2 Read Timing

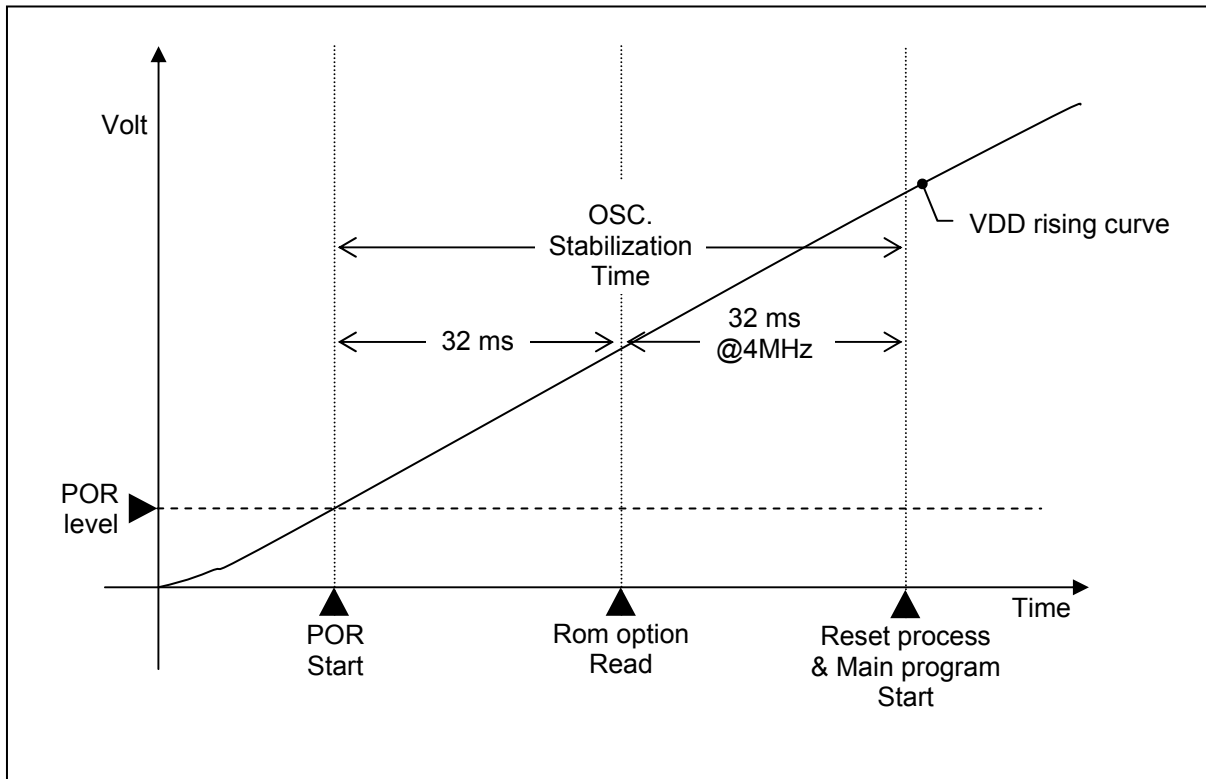

Figure 8-1 ROM option read timing diagram

Rom option is affected 32 milli-second (typically) after VDD cross the POR level. More precisely saying, the 32 milli-second is the time for 1/2 counting of 1024 divided BIT with 4 MHz internal OSC. After the ROM option is affected, system clock source is changed based on the ROM option. And then, rest 1/2 counting is continued with changed clock source. So, hole stabilization time is variable depend on the clock source.

	Before read ROM option	After read ROM option	OSC Stabilization Time
Formula	$250\text{ns} \times 128(\text{BTCR}) \times 1024(\text{divider})$	$\text{Period} \times 128(\text{BTCR}) \times 1024(\text{divider})$	Before + After
Int-RC 4MHz	32 ms	32 ms	64 ms
Int-RC 8MHz	32 ms	16 ms	48 ms
X-tal 12 MHz	32 ms	10.7 ms	42.7 ms
X-tal 16 Mhz	32 ms	8 ms	40 ms

Table 8-1 examples of OSC stabilization time

Note that ROM option is affected in OSC stabilization time. So even you change the ROM option by ISP. It is not affected until system is reset. In other words, you must reset the system after change the ROM option.

9. MEMORY ORGANIZATION

This MCU has separated address spaces for the *program memory* and the *data Memory*.

The program memory is a ROM which stores a program code. It is not possible to write a data at the program memory while the MCU is running.

The Data Memory is a REM which is used by MCU at running time.

9.1 Registers

There are few registers which are used for MCU operating.

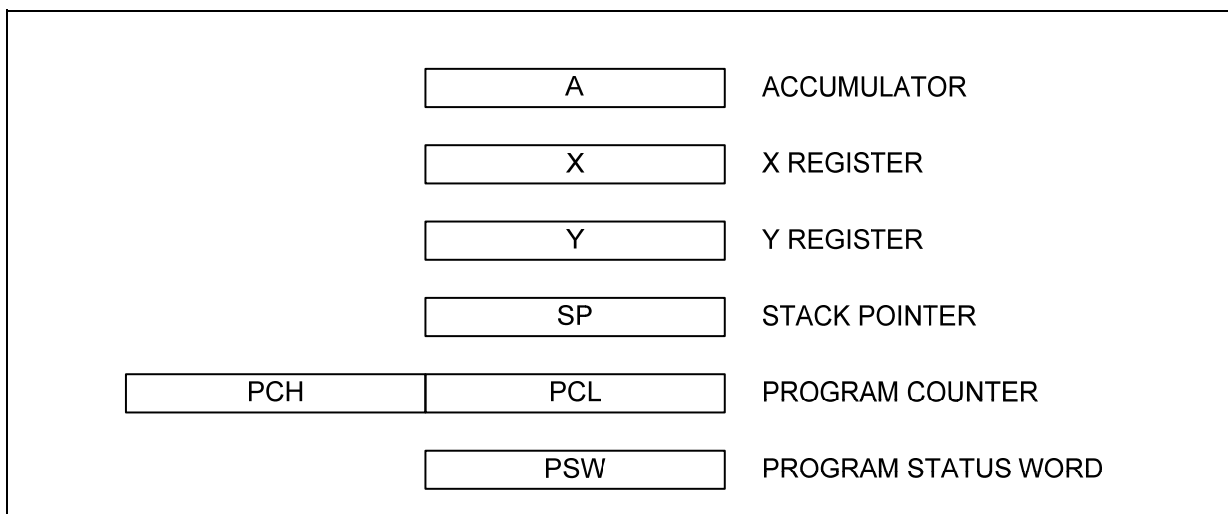

Figure 9-1 Configuration of Registers

Accumulator(A Register) : Accumulator is the 8-bit general purpose register, which is used for accumulating and some data operations such as transfer, temporary saving, and conditional judgment , etc.

And it can be used as a part of 16-bit register with Y Register as shown below.

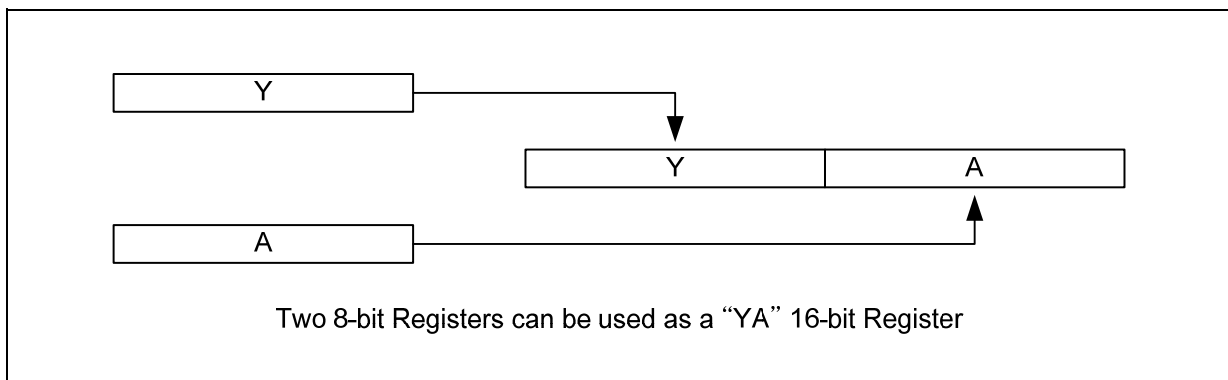

Figure 9-2 Configuration of YA 16-bit Registers

X, Y Registers: In the addressing mode, these are used as a index register. It makes it possible to access at Xth or Yth memory from specific address. It is extremely effective for referencing a subroutine table and a memory table.

These registers also have increment, decrement, comparison and data transfer functions, and they can be used as a simple accumulator.

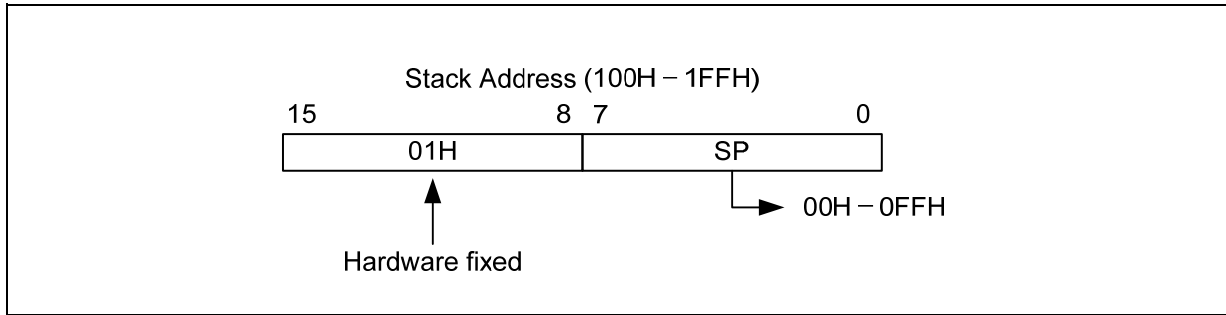

Figure 9-3 Stack Pointer

Stack Pointer: Stack Pointer is an 8-bit register which indicates the current ‘push’ point in the stack area. It is used to push and pop when interrupts or general function call is occurred. Stack Pointer identifies the location in the stack to be accessed (save or restore).

Generally, SP is automatically updated when a subroutine call is executed or an interrupt is accepted. However, if it is used in excess of the stack area permitted by the data memory allocating configuration, the user-processed data may be lost.

The stack can be located at any position within 100H to 1FFH of the internal data memory. The SP is not initialized by hardware, requiring to write the initial value (the location with which the use of the stack starts) by using the initialization routine. Normally, the initial value of “FFH” is used.

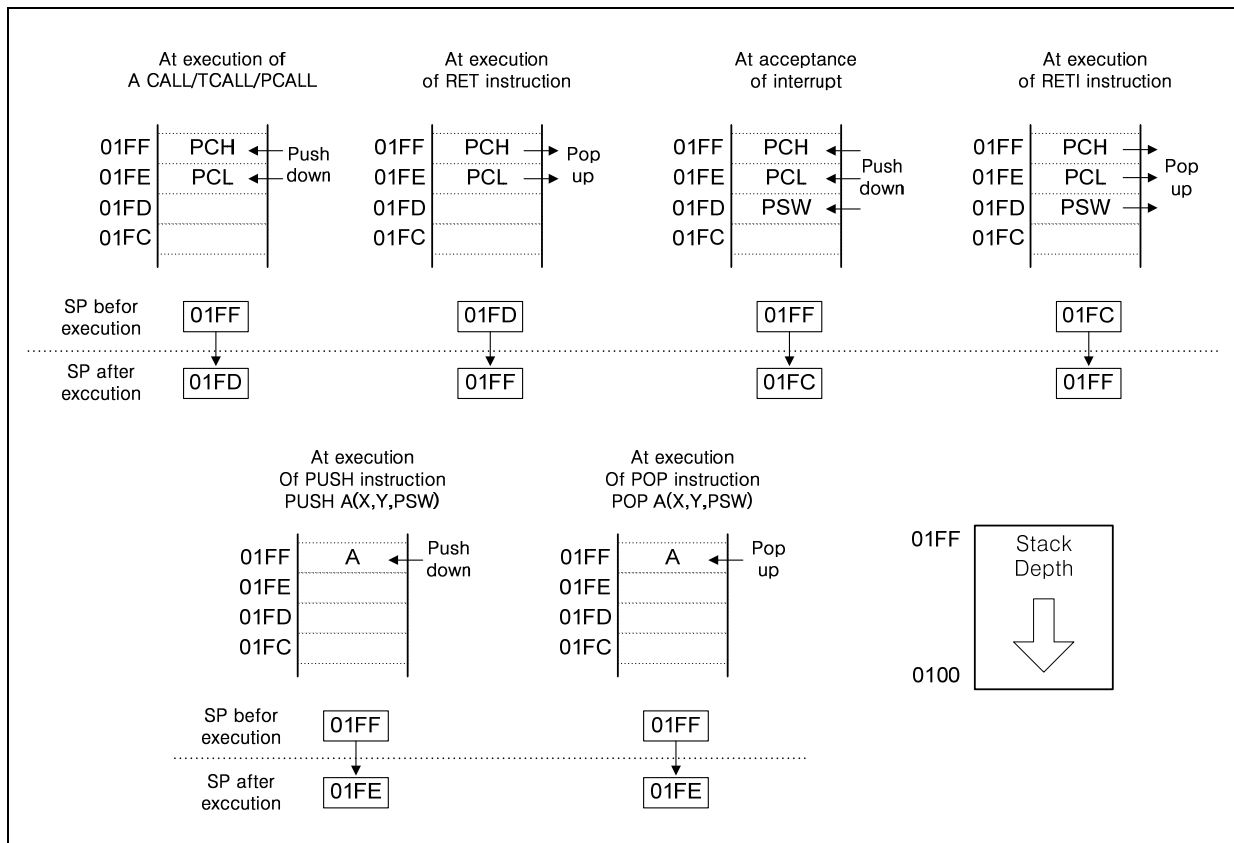

Figure 9-4 Stack Operation

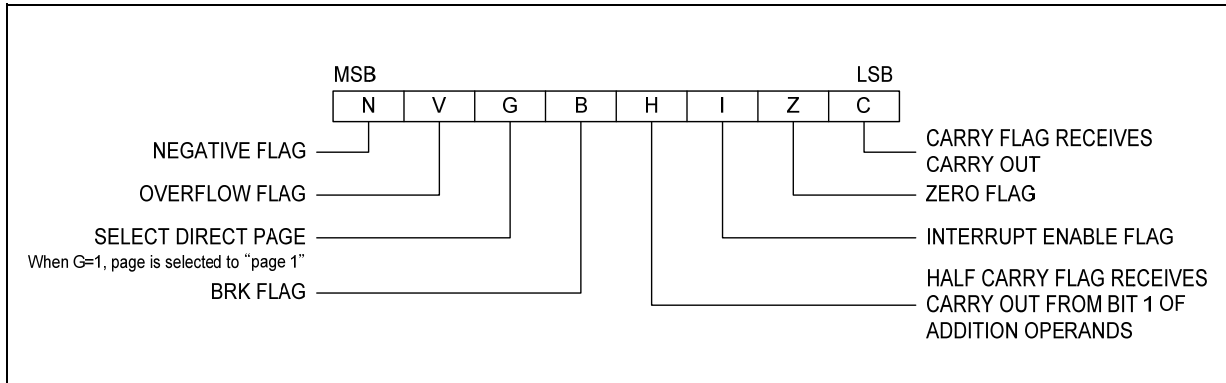

Figure 9-5 PSW (Program Status Word) Registers

Program Status Word: Program Status Word (PSW) contains several bits that reflect the current state of the CPU. It contains the Negative flag, the Overflow flag, the Break flag, the Half Carry (for BCD operation), the Interrupt enable flag, the Zero flag, and the Carry flag.

[Carry flag C]

This flag stores any carry or borrow from the ALU of CPU after an arithmetic operation and is also changed by the Shift Instruction or Rotate Instruction.

[Zero flag Z]

This flag is set when the result of an arithmetic operation or data transfer is "0" and is cleared by any other result.

[Interrupt disable flag I]

This flag enables/disables all interrupts except interrupt caused by Reset or software BRK instruction. All interrupts are disabled when cleared to "0". This flag immediately becomes "0" when an interrupt is served. It is set by the EI instruction and cleared by the DI instruction.

[Half carry flag H]

After operation, this is set when there is a carry from bit 3 of ALU or there is no borrow from bit 4 of ALU. This bit can not be set or cleared except CLR V instruction with Overflow flag (V).

[Break flag B]

This flag is set by software BRK instruction to distinguish BRK from TCALL instruction with the same vector address.

[Direct page flag G]

This flag assigns RAM page for direct addressing mode. In the direct addressing mode, addressing area is from zero page 00H to 0FFH when this flag is "0". If it is set to "1", addressing area is assigned 100H to 1FFH. It is set by SETG instruction and cleared by CLRG.

[Overflow flag V]

This flag is set to "1" when an overflow occurs as the result of an arithmetic operation involving signs. An overflow occurs when the result of an addition or subtraction exceeds +127(7FH) or -128(80H). The CLR V instruction clears the overflow flag. There is no set instruction. When the BIT instruction is executed, bit 6 of memory is copied to this flag.

[Negative flag N]

This flag is set to match the sign bit (bit 7) status of the result of a data or arithmetic operation. When the BIT instruction is executed, bit 7 of memory is copied to this flag.

9.2 Program Memory

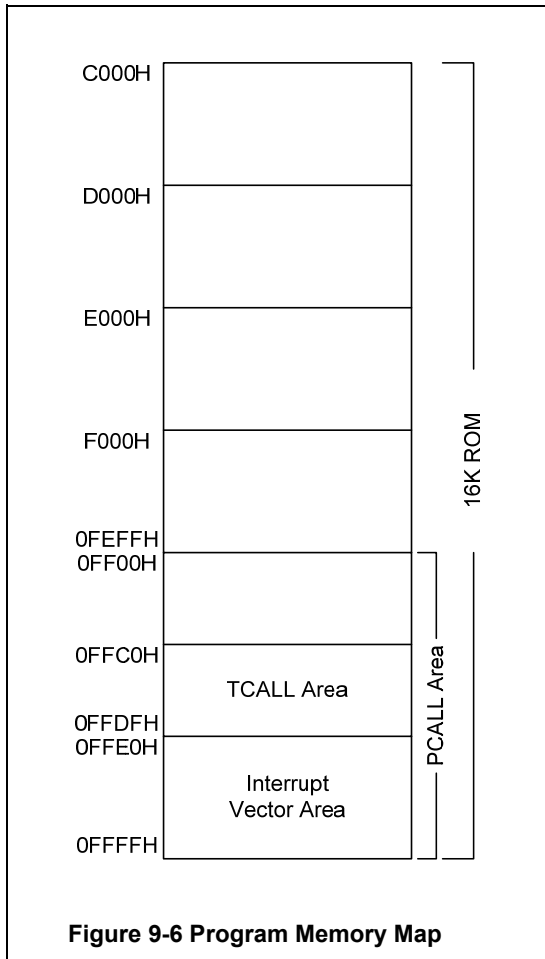

Figure 9-6 Program Memory Map

A 16-bit program counter is capable of addressing up to 64K bytes, but this device has 16K bytes program memory space only physically implemented. Accessing a location above FFFFH will cause a wrap-around to 0000H.

Figure 9-6 shows a map of Program Memory. After reset, the CPU begins execution from reset vector which is stored in address FFFE0H and FFFFH. As shown in Figure 9-6, each area is assigned a fixed location in Program Memory.

Program memory area contains the user program Page Call (PCALL) area contains subroutine program to reduce program byte length by using 2 bytes PCALL instead of 3 bytes CALL instruction. If it is frequently called, it is more useful to save program byte length.

Table Call (TCALL) causes the CPU to jump to each TCALL address, where it commences the execution of the service routine. The Table Call service area spaces 2-byte for every TCALL: 0FFC0H for TCALL15, 0FFC2H for TCALL14, etc., as shown in Figure 9-7.

The interrupt causes the CPU to jump to specific location where it commences the execution of the service routine. The interrupt service locations spaces 2-byte interval. The External interrupt 1, for Example, is

assigned to location 0FFFCH.

Any area from 0FF00H to 0FFFFH, if it is not going to be used, its service location is available as general purpose Program Memory.

PCALL → rel

4F35 PCALL 35H

TCALL → n

4A TCALL 4

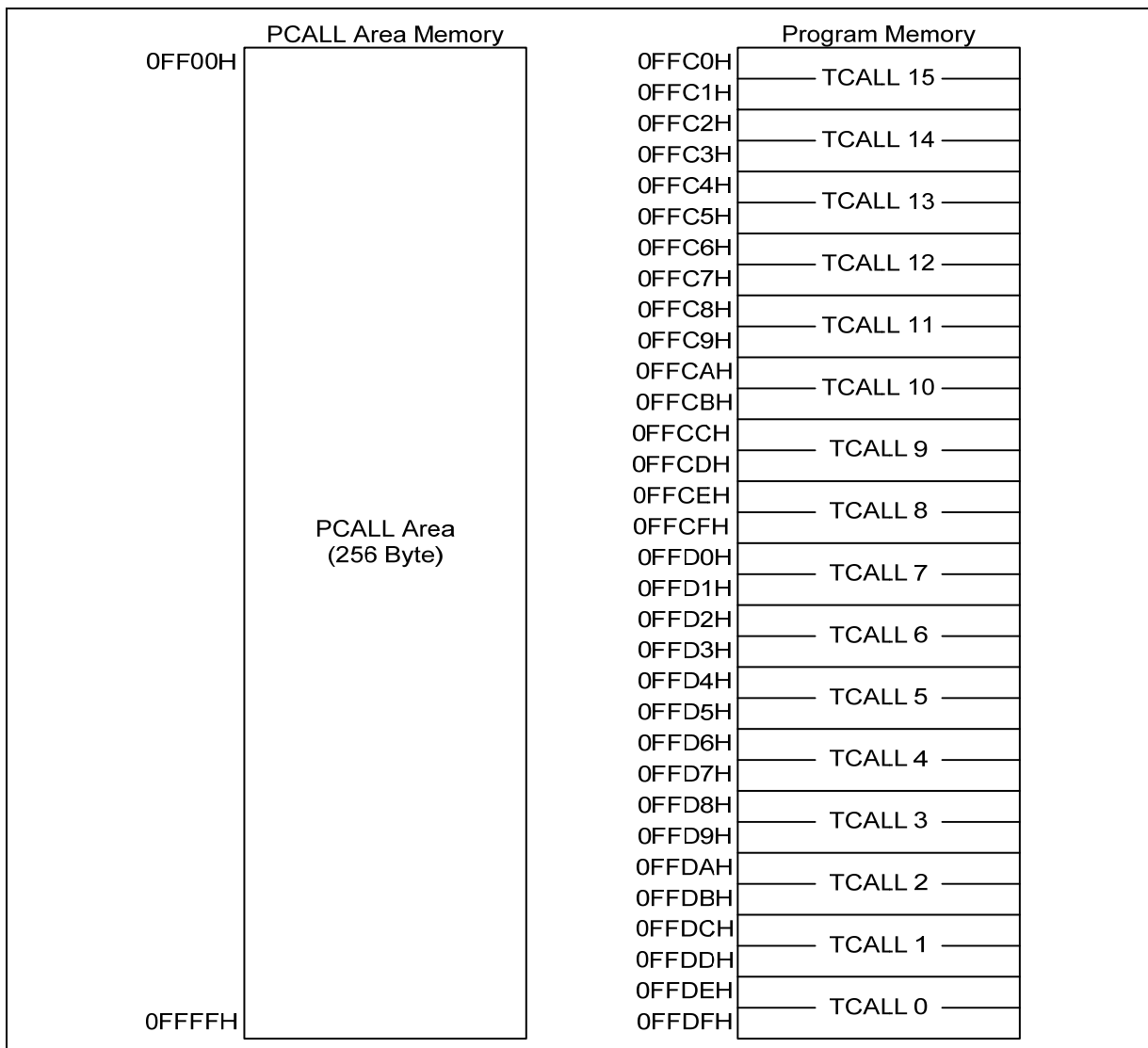
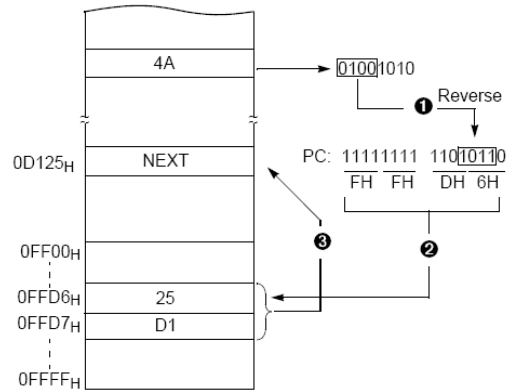
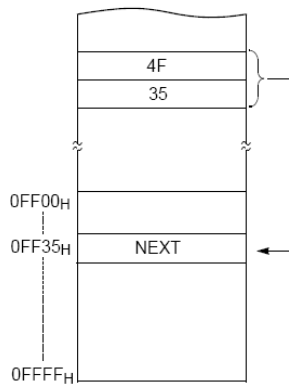

Figure 9-7 PCALL and TCALL Memory Area

Example : Usage of TCALL

```
LDA #5
TCALL 0FH          ;1BYTE INSTRUCTION
:                ;INSTEAD OF 3 BYTES
:                ;NORMAL CALL

;TABLE CALL ROUTINE

FUNC_A : LDA LRG0
RET

FUNC_B : LDA LRG1
RET

;TABLE CALL ADD. AREA

ORG 0FFC0H        ;TCALL ADDRESS AREA
DW FUNC_A
DW FUNC_B
```

9.3 Data Memory

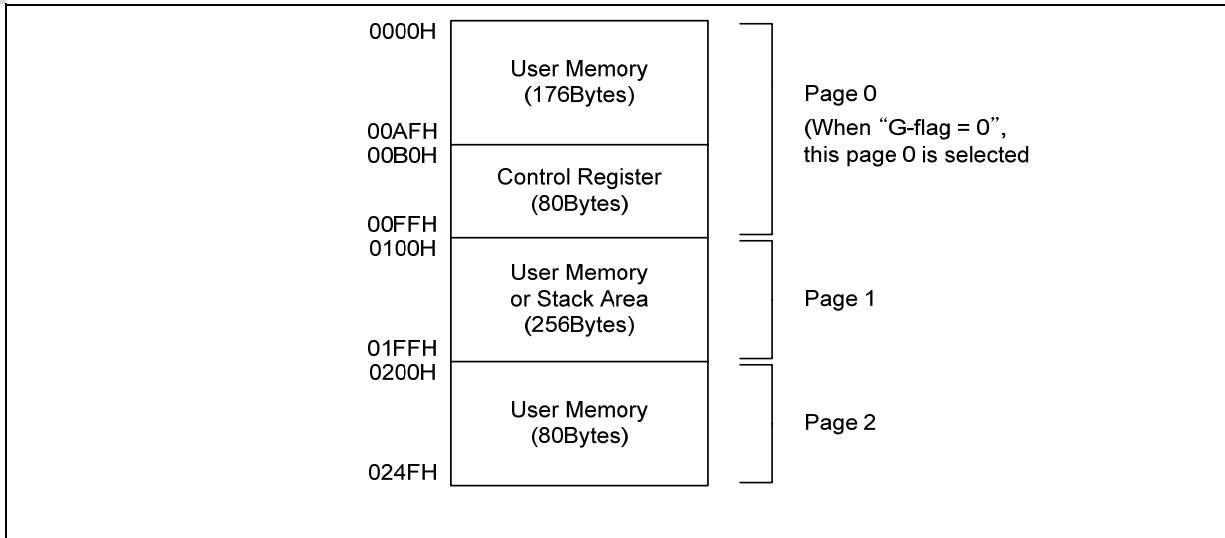

Figure 9-8 Data Memory Map

Figure 9-8 shows the internal Data Memory space available. Data Memory is divided into three groups, a user RAM, Stack memory and Control registers.

9.4 User Memory

The MC81F4x16 has a 512 bytes user memory (RAM). RAM pages are selected by the RPR register.

RPR

RAM PAGE SELECT REGISTER

00E1H

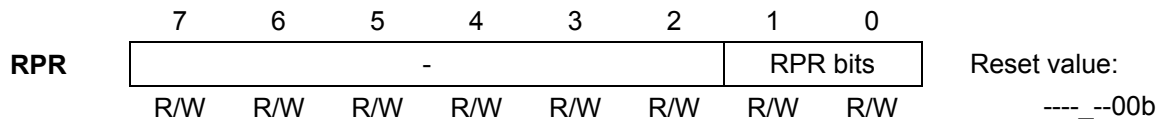

RPR bits	Ram Page Select bits	00: page 0 01: page 1 10: page 2
-----------------	----------------------	--

NOTE: After setting RPR(RAM Page Select Register), be sure to execute SETG instruction. Whenever CLRG instruction is executed, PAGE0 is selected regardless of RPR.

9.5 Stack Area

The stack provides the area where the return address is saved before a jump is performed during the processing routine at the execution of a subroutine call instruction or the acceptance of an interrupt.

When returning from the processing routine, executing the subroutine return instruction [RET] restores the contents of the program counter from the stack; executing the interrupt return instruction [RETI] restores the contents of the program counter and flags.

The save/restore locations in the stack are determined by the stack pointer (SP). The SP is automatically decreased after the saving, and increased before the restoring. This means the value of the SP indicates the stack location number for the next save. Refer to Figure 9-4. .

9.6 Control Registers (SFR)

The control registers are used by the CPU and Peripheral function blocks for controlling the desired operation of the device. Therefore these registers contain control and status bits for the interrupt system, the timer/ counters, analog to digital converters and I/O ports. The control registers are in address range of 0B0H to 0FFH. It also be called by SFR(Special Function Registers).

Note that unoccupied addresses may not be implemented on the chip. Read accesses to these addresses will in general return random data, and write accesses will have an indeterminate effect.

More detailed information of each registers are explained in each peripheral section.

Example : To write at CKCTLR

```
LDM CKCTLR,#0AH ;Divide ratio(÷32)
```

Address	Register Name	Symbol	R/W	Initial Value								Addressing Mode		
				7	6	5	4	3	2	1	0			
00B0	Timer 0 Status And Control Register	T0SCR	R/W	0	0	0	0	0	0	0	0	0	0	Byte, bit
00B1	Timer 0 Data Register	T0DR	R/W	1	1	1	1	1	1	1	1	1	1	Byte, bit
00B2	Timer 0 Counter Register	T0CR	R	0	0	0	0	0	0	0	0	0	0	Byte, bit
00B3	Timer 1 Status And Control Register	T1SCR	R/W	–	0	0	0	0	0	0	0	0	0	Byte, bit
00B4	Timer 1 Data Register	T1DR	R/W	1	1	1	1	1	1	1	1	1	1	Byte, bit
00B5	Timer 1 Counter Register	T1CR	R	0	0	0	0	0	0	0	0	0	0	Byte, bit
00B6	Timer 2 Status And Control Register	T2SCR	R/W	0	–	0	0	0	0	0	0	0	0	Byte, bit
00B7	Timer 2 Data Register	T2DR	R/W	1	1	1	1	1	1	1	1	1	1	Byte, bit
00B8	Timer 2 Counter Register	T2CR	R	0	0	0	0	0	0	0	0	0	0	Byte, bit
00B9	Timer 3 Status And Control Register	T3SCR	R/W	–	–	0	0	0	0	0	0	0	0	Byte, bit
00BA	Timer 3 Data Register	T3DR	R/W	1	1	1	1	1	1	1	1	1	1	Byte, bit
00BB	Timer 3 Counter Register	T3CR	R	0	0	0	0	0	0	0	0	0	0	Byte, bit
00BC	Oscillator Select Register	OSCSEL	R/W	–	–	–	–	–	0	0	0	0	0	Byte, bit
00BD	A/D Mode Register	ADMR	R/W	0	0	0	0	0	0	0	0	0	0	Byte, bit
00BE	A/D Converter Data High Register	ADDRH	R	X	X	X	X	X	X	X	X	X	X	Byte, bit
00BF	A/D Converter Data Low Register	ADDRL	R	X	X	X	X	–	–	–	–	–	–	Byte, bit
00C0	R0 Port Data Register	R0	R/W	0	0	0	0	0	0	0	0	0	0	Byte, bit
00C1	R1 Port Data Register	R1	R/W	1	1	1	1	1	0	0	0	0	0	Byte, bit
00C2	R2 Port Data Register	R2	R/W	1	1	1	1	1	1	1	1	1	1	Byte, bit
00C3	R3 Port Data Register	R3	R/W	–	–	0	0	0	1	1	1	1	1	Byte, bit
00C4	R4 Port Data Register	R4	R/W	1	1	1	1	1	1	1	1	1	1	Byte, bit
00C5	R5 Port Data Register	R5	R/W	–	–	–	–	1	1	1	1	1	1	Byte, bit
00C6	R0 Port Control High Register	R0CONH	R/W	0	0	0	0	0	0	–	0	0	0	Byte, bit
00C7	R0 Port Control Middle Register	R0CONM	R/W	0	0	0	0	0	0	0	0	0	0	Byte, bit
00C8	R0 Port Control Low Register	R0CONL	R/W	–	–	0	0	0	0	0	0	0	0	Byte, bit
00C9	R0 Port Pull-up Enable Register	PUR0	R/W	0	0	0	0	0	0	0	0	0	0	Byte, bit
00CA	R0 Port External Interrupt High Register	EINT0H	R/W	0	0	0	0	0	0	0	0	0	0	Byte, bit
00CB	R0 Port External Interrupt Low Register	EINT0L	R/W	0	0	0	0	0	0	0	0	0	0	Byte, bit
00CC	R0 Port External Interrupt Request Register	ERQ0	R/W	0	0	0	0	0	0	0	0	0	0	Byte, bit
00CD	External Interrupt Flag Register	EINTF	R/W	0	0	0	0	0	0	0	0	0	0	Byte, bit
00CE	PWM Status And Control Register	PWMSCR	R/W	0	0	0	0	–	–	–	–	–	–	Byte, bit
00CF	PWM Period And Duty Register	PWMPDR	R/W	1	1	1	1	1	1	1	1	1	1	Byte, bit
00D0	PWM2 Data Register	PWM2DR	R/W	1	1	1	1	1	1	1	1	1	1	Byte, bit
00D1	PWM3 Data Register	PWM3DR	R/W	1	1	1	1	1	1	1	1	1	1	Byte, bit
00D2	PWM4 Data Register	PWM4DR	R/W	1	1	1	1	1	1	1	1	1	1	Byte, bit
00D3	R1 Port Control High Register	R1CONH	R/W	0	1	0	1	0	1	0	1	0	1	Byte, bit
00D4	R1 Port Control Middle Register	R1CONM	R/W	0	0	1	0	0	0	–	–	–	–	Byte, bit
00D5	R1 Port Control Low Register	R1CONL	R/W	–	–	–	0	0	0	0	0	0	0	Byte, bit

Table 9-1 Control Register 1/4

Address	Register Name	Symbol	R/W	Initial Value								Addressing Mode	
				7	6	5	4	3	2	1	0		
00D6	R1 Port Pull-up Enable Register	PUR1	R/W	0	0	0	0	0	0	0	0	0	Byte, bit
00D7	R1 Port External Interrupt Register	EINT1	R/W	0	0	0	0	0	0	0	0	0	Byte, bit
00D8	R1 Port External Interrupt Request Register	ERQ1	R/W	-	-	-	-	0	0	0	0	0	Byte, bit
00D9	R2 Port Control High Register	R2CONH	R/W	0	1	0	1	0	1	0	1	0	Byte, bit
00DA	R2 Port Control Low Register	R2CONL	R/W	0	1	0	1	0	1	0	1	0	Byte, bit
00DB	R2 Port Pull-up Enable Register	PUR2	R/W	0	0	0	0	0	0	0	0	0	Byte, bit
00DC	R3 Port Control High Register	R3CONH	R/W	-	-	0	0	0	0	0	0	0	Byte, bit
00DD	R3 Port Control Low Register	R3CONL	R/W	1	0	0	1	1	0	1	1	1	Byte, bit
00DE	R4 Port Control High Register	R4CONH	R/W	1	0	1	0	1	0	1	0	0	Byte, bit
00DF	R4 Port Control Low Register	R4CONL	R/W	1	0	1	0	1	0	1	0	0	Byte, bit
00E0	R5 Port Control Register	R5CON	R/W	1	0	1	0	1	0	1	0	0	Byte, bit
00E1	RAM Page Selection Register	RPR	R/W	-	-	-	-	-	-	0	0	0	Byte, bit
00E2	Slave IIC Status And Control Register	IICSCR	R/W	0	0	0	0	0	0	0	0	0	Byte, bit
00E3	Slave IIC Address Register	IICAR	R/W	X	X	X	X	X	X	X	-	-	Byte, bit
00E4	Slave IIC Data Shift Register	IICDSR	R/W	X	X	X	X	X	X	X	X	X	Byte, bit
00E5	Buzzer Control Register	BUZR	R/W	1	1	0	0	-	-	-	-	-	Byte, bit
00E6	Buzzer Period Data Register	BUPDR	R/W	1	1	1	1	1	1	1	1	1	Byte, bit
00E7	SIO Control Register	SIOCR	R/W	-	-	0	0	0	0	0	0	0	Byte, bit
00E8	SIO Data Register	SIODAT	R/W	0	0	0	0	0	0	0	0	0	Byte, bit
00E9	SIO Pre-scaler Register	SIOPS	R/W	0	0	0	0	0	0	0	0	0	Byte, bit
00EA	Interrupt Enable High Register	IENH	R/W	0	0	0	0	0	0	0	0	0	Byte, bit
00EB	Interrupt Enable Low Register	IENL	R/W	0	0	0	0	0	0	-	0	0	Byte, bit
00EC	Interrupt Request High Register	IRQH	R/W	0	0	0	0	0	0	0	0	0	Byte, bit
00ED	Interrupt Request Low Register	IRQL	R/W	0	0	0	0	0	0	-	0	0	Byte, bit
00EE	Interrupt Flag High Register	INTFH	R/W	0	0	0	0	0	0	0	0	0	Byte, bit
00EF	Interrupt Flag Low Register	INTFL	R/W	0	-	-	-	-	-	0	0	0	Byte, bit
00F0	Watch Timer Status And Control Register	WTSCR	R/W	-	0	0	0	0	-	-	0	0	Byte, bit
00F1	Basic Timer Counter Register	BTCCR	R	X	X	X	X	X	X	X	X	X	Byte, bit
00F2	Clock control Register	CKCTLR	R/W	-	-	-	1	0	1	1	1	1	Byte, bit
00F3	Power On Reset Control Register	PORC	R/W	0	0	0	0	0	0	0	0	0	Byte, bit
00F4	Watchdog Timer Register	WDTR	R/W	0	1	1	1	1	1	1	1	1	Byte, bit
00F5	Stop & Sleep Mode Control Register	SSCR	R/W	0	0	0	0	0	0	0	0	0	Byte, bit
00F6	Watchdog Timer Status Register	WDTSR	R/W	0	0	0	0	0	0	0	0	0	Byte, bit
00F7	Watchdog Timer Counter Register	WDTCR	R	X	X	X	X	X	X	X	X	X	Byte, bit
00FC	UART Control High Register	UCONH	R/W	0	0	0	0	0	0	-	-	-	Byte, bit
00FD	UART Control Low Register	UCONL	R/W	0	0	0	0	0	0	-	-	-	Byte, bit
00FE	UART Data Register	UDAT	R/W	X	X	X	X	X	X	X	X	X	Byte, bit
00FF	UART Baud Rate Data Register	BRDAT	R/W	1	1	1	1	1	1	1	1	1	Byte, bit

Table 9-2 Control Register 2/4

Address	Name	Bit 7	Bit 6	Bit 5	Bit 4	Bit 3	Bit 2	Bit 1	Bit 0	
00B0H	T0SCR	T0MOD	T0MS		T0CC	T0CS				
00B1H	T0DR	Timer 0 Data Register								
00B2H	T0CR	Timer 0 Counter Register								
00B3H	T1SCR	-	T1MS		T1CC	T1CS				
00B4H	T1DR	Timer 1 Data Register								
00B5H	T1CR	Timer 1 Counter Register								
00B6H	T2SCR	T2MOD	-	T2MS	T2CC	T2CS				
00B7H	T2DR	Timer 2 Data Register								
00B8H	T2CR	Timer 2 Counter Register								
00B9H	T3SCR	-	-	T3MS	T3CC	T3CS				
00BAH	T3DR	Timer 3 Data Register								
00BBH	T3CR	Timer 3 Counter Register								
00BCH	OSCSEL	-	-	-	-	-	MOSC	SOSC	SCLK	
00BDH	ADMR	SSBIT	EOC	ADCLK		ADCH				
00BEH	ADDRH	A/D Converter Data High Register								
00BFH	ADDRL	A/D Converter Data Low Register								
00C0H	R0	R0 Port Data Register								
00C1H	R1	R1 Port Data Register								
00C2H	R2	R2 Port Data Register								
00C3H	R3	R3 Port Data Register								
00C4H	R4	R4 Port Data Register								
00C5H	R5	R5 Port Data Register								
00C6H	R0CONH	R07			R06			-	R05	
00C7H	R0CONM	R05		R04			R03			
00C8H	R0CONL	-	-	R02		R01		R00		
00C9H	PUR0	PUR07	PUR06	PUR05	PUR04	PUR03	PUR02	PUR01	PUR00	
00CAH	EINT0H	EXT5IE		EXT4IE		EXT3IE		EXT2IE		
00CBH	EINT0L	EXT1IE		EXT0IE		EXT11IE		EXT10IE		
00CCH	ERQ0	EXT5IR	EXT4IR	EXT3IR	EXT2IR	EXT1IR	EXT0IR	EXT11IR	EXT10IR	
00CDH	EINTF	EXT0IF	EXT2IF	EXT4IF	EXT7IF	EXT8IF	EXT9IF	EXT10IF	EXT11IF	
00CEH	PWMSCR	POL4	POL3	POL2	PWMS	-	-	-	-	
00CFH	PWMPDR	P4DH	P4DL	P3DH	P3DL	P2DH	P2DL	PPH	PPL	
00D0H	PWM2DR	PWM 2 Data Register								
00D1H	PWM3DR	PWM 3 Data Register								
00D2H	PWM4DR	PWM 4 Data Register								
00D3H	R1CONH	R17		R16		R15		R14		
00D4H	R1CONM	R13			R12			-	-	
00D5H	R1CONL	-	-	-	R11			R10		

Table 9-3 Control Register 3/4

Address	Name	Bit 7	Bit 6	Bit 5	Bit 4	Bit 3	Bit 2	Bit 1	Bit 0
00D6H	PUR1	PUR17	PUR16	PUR15	PUR14	PUR13	PUR12	PUR11	PUR10
00D7H	EINT1	EXT9IE		EXT8IE		EXT7IE		EXT6IE	
00D8H	ERQ1	-	-	-	-	EXT9IR	EXT8IR	EXT7IR	EXT6IR
00D9H	R2CONH	R27		R26		R25		R24	
00DAH	R2CONL	R23		R22		R21		R20	
00DBH	PUR2	PUR27	PUR26	PUR25	PUR24	PUR23	PUR22	PUR21	PUR20
00DCH	R3CONH	-	-	R35		R34		R33	
00DDH	R3CONL	R32		R31			R30		
00DEH	R4CONH	R47		R46		R45		R44	
00DFH	R4CONL	R43		R42		R41		R40	
00E0H	R5CON	R53		R52		R51		R50	
00E1H	RPR	-	-	-	-	-	-	RPR1	RPR0
00E2H	IICSCR	ACKE	IICEN	IICIFEN	IICAZS	IICTR	IICBS	SAM	IICLR
00E3H	IICAR	Slave IIC Address register							
00E4H	IICDSR	Slave IIC Tx/Rx Data Shift Register							
00E5H	BUZR	BUCK		BUSS	BURL	-	-	-	-
00E6H	BUPDR	Buzzer Period Data Register							
00E7H	SIOCR	-	-	CSEL	DAT	SIOM	SIOP	CCLR	SEDGE
00E8H	SIODAT	SIO Data register							
00E9H	SIOPS	SIO Pre-Scale register							
00EAH	IENH	T0MIE	T0OVIE	T1MIE	T1OVIE	T2MIE	T2OVIE	T3MIE	T3OVIE
00EBH	IENL	IICIE	SIOIE	WTIE	URIE	UTIE	WDTIE	-	BTIE
00ECH	IRQH	T0MIR	T0OVIR	T1MIR	T1OVIR	T2MIR	T2OVIR	T3MIR	T3OVIR
00EDH	IRQL	IICIR	SIOIR	WTIR	URIR	UTIR	WDTIR	-	BTIR
00EEH	INTFH	T0MIF	T0OVIF	T1MIF	T1OVIF	T2MIF	T2OVIF	T3MIF	T3OVIF
00EFH	INTFL	IICIF	-	-	-	-	-	URIF	UTIF
00F0H	WTSCR	-	WTEN	WTSS			-	-	WTCS
00F1H	BTCR	Basic Timer Counter Register							
00F2H	CKCTLR	-	-	-	WDTON	BTCL	BTS		
00F3H	PORC	Power On Reset Control register							
00F4H	WDTR	WDTCL	WDTCMP						
00F5H	SSCR	Stop and Sleep Control Register							
00F6H	WDTSR	Watchdog Timer Status Register							
00F7H	WDTCR	Watchdog Timer Counter Register							
00FCH	UCONH	UMS1	UMS0	MCE	SDR	TB8	RB8	-	-
00FDH	UCONL	UTP	UTPS	URPS	URPER	UCLK		-	-
00FEH	UDAT	UART Data Register							
00FFH	BRDAT	UART Baud Rate Register							

Table 9-4 Control Register 4/4

9.7 Addressing modes

The MC81Fxxx series MCU uses six addressing modes;

- Register Addressing
- Immediate Addressing
- Direct Page Addressing
- Absolute Addressing
- Indexed Addressing
- Indirect Addressing

Register Addressing

Register addressing means to access to the data of the A, X, Y, C and PSW registers. For Example 'ASL (Arithmetic Shift Left)' only accesses the A register.

Immediate Addressing

In this mode, second byte (operand) is accessed as a data immediately.

Example :

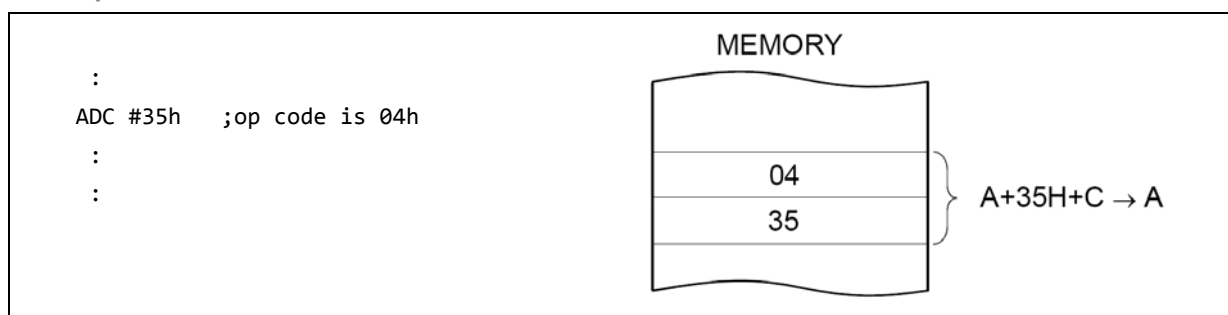

When G-flag is 1, then RAM address is defined by 16-bit address which is composed of 8-bit RAM paging register (RPR) and 8-bit immediate data.

Example :

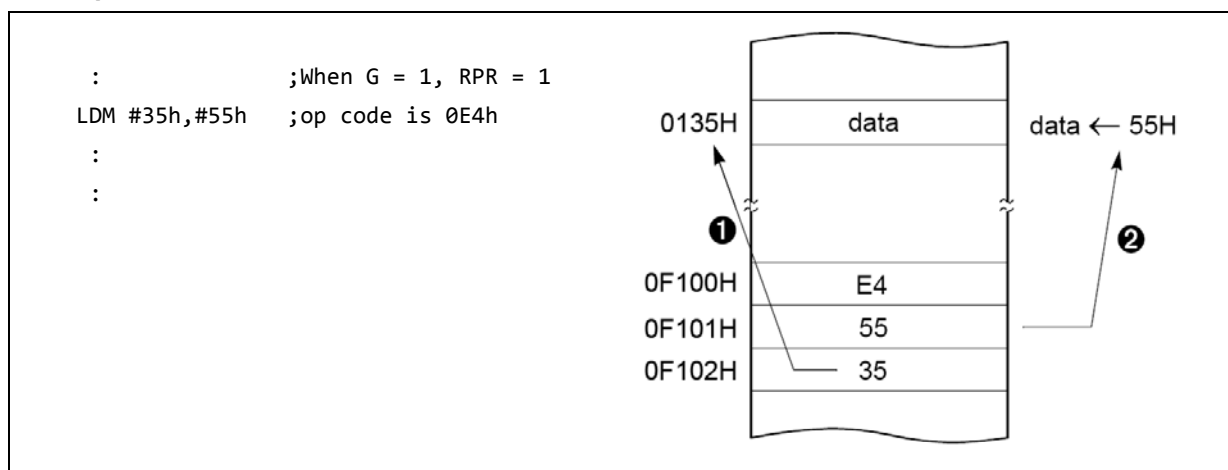

Direct Page Addressing -> dp

In this mode, an address is specified within direct page. Current accessed page is selected by RPR(RAM Page select Register). And dp(Direct Page) is an one byte data which indicates the target address in the current accessed page.

Example :

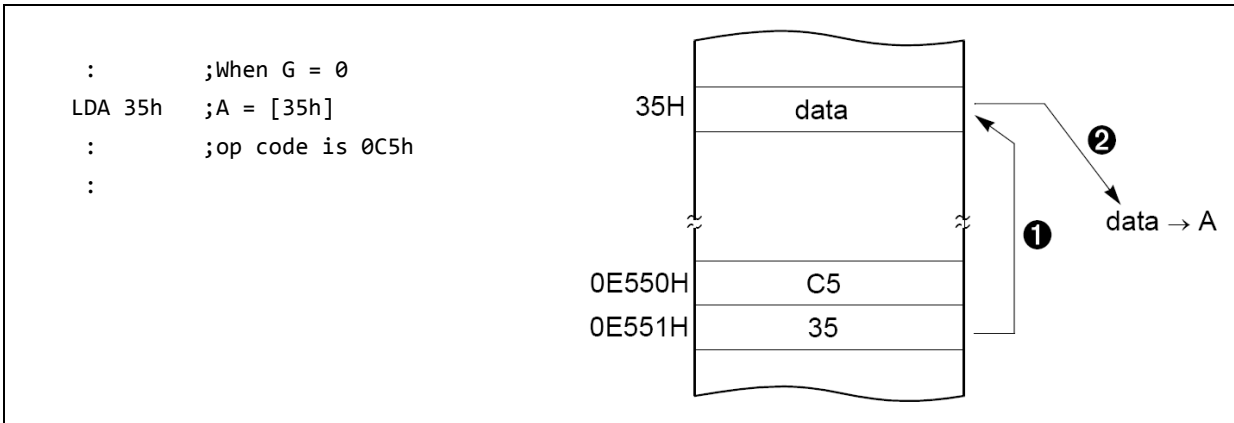

Absolute Addressing

Absolute addressing sets corresponding memory data to Data, i.e. second byte (Operand I) of command becomes lower level address and third byte (Operand II) becomes upper level address. With 3 bytes command, it is possible to access to whole memory area.

ADC, AND, CMP, CMPX, CMPY, EOR, LDA, LDX, LDY, OR, SBC, STA, STX, STY

The operation within data memory (RAM) : ASL, BIT, DEC, INC, LSR, ROL, ROR

Example :

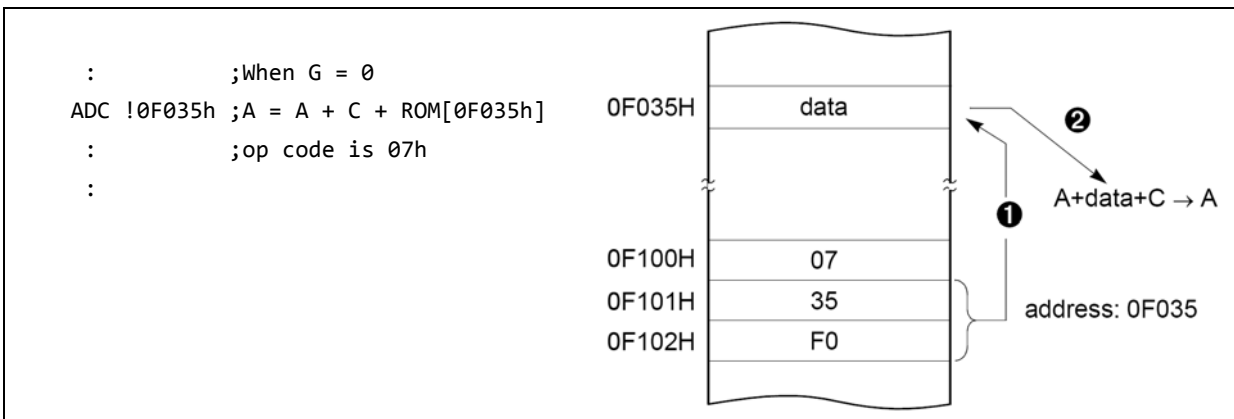

Example : Addressing accesses the address 0135H regardless of G-flag.

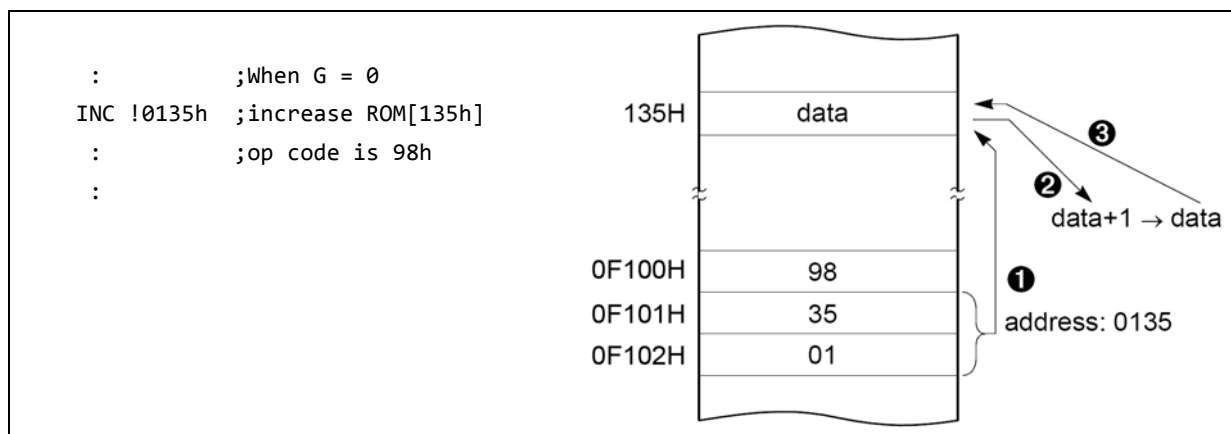

Indexed Addressing

X indexed direct page (no offset) → {X}

In this mode, an address is specified by the X register.

ADC, AND, CMP, EOR, LDA, OR, SBC, STA, XMA

Example :

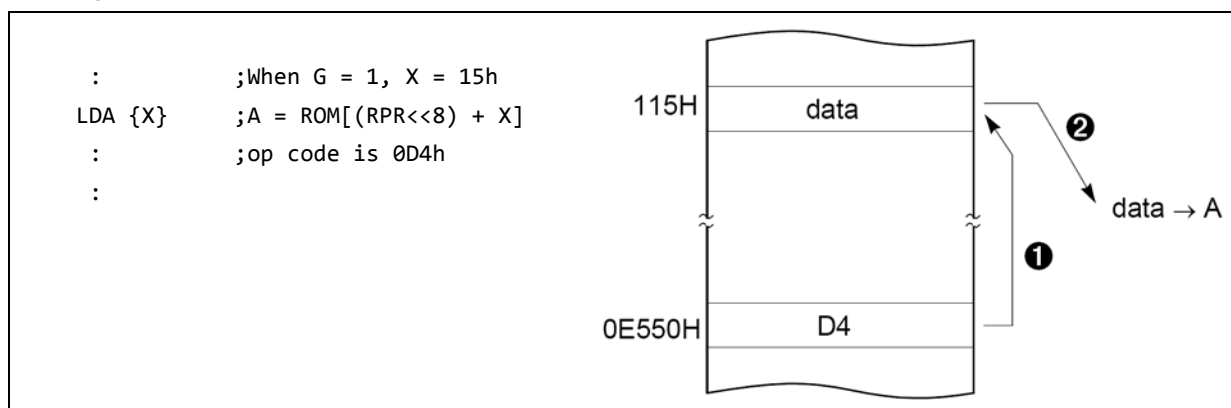

X indexed direct page, auto increment → {X}+

In this mode, a address is specified within direct page by the X register and the content of X is increased by 1.

LDA, STA

Example:

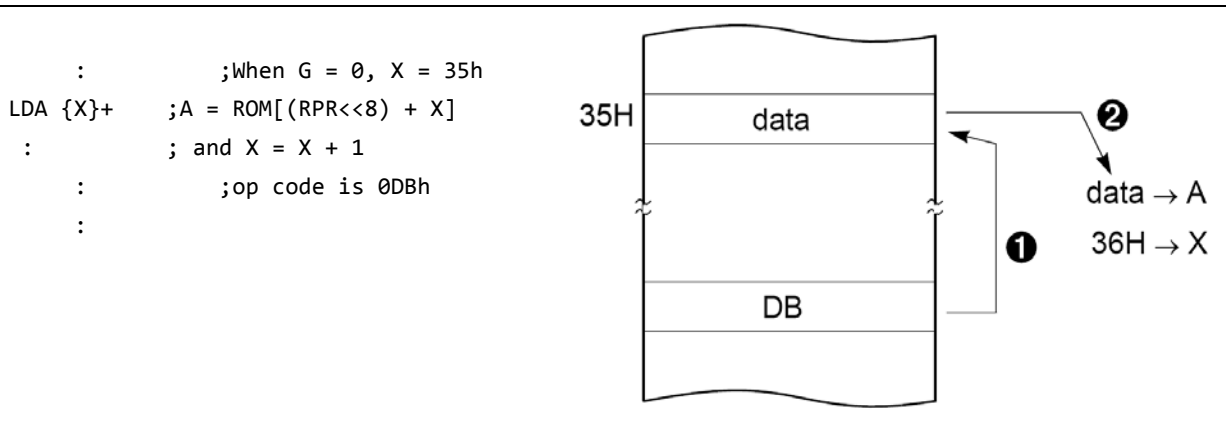

X indexed direct page (8 bit offset) → dp+X

This address value is the second byte (Operand) of command plus the data of X-register. And it assigns the memory in direct page.

ADC, AND, CMP, EOR, LDA, LDY, OR, SBC, STA,STY, XMA, ASL, DEC, INC, LSR, ROL, ROR

Example :

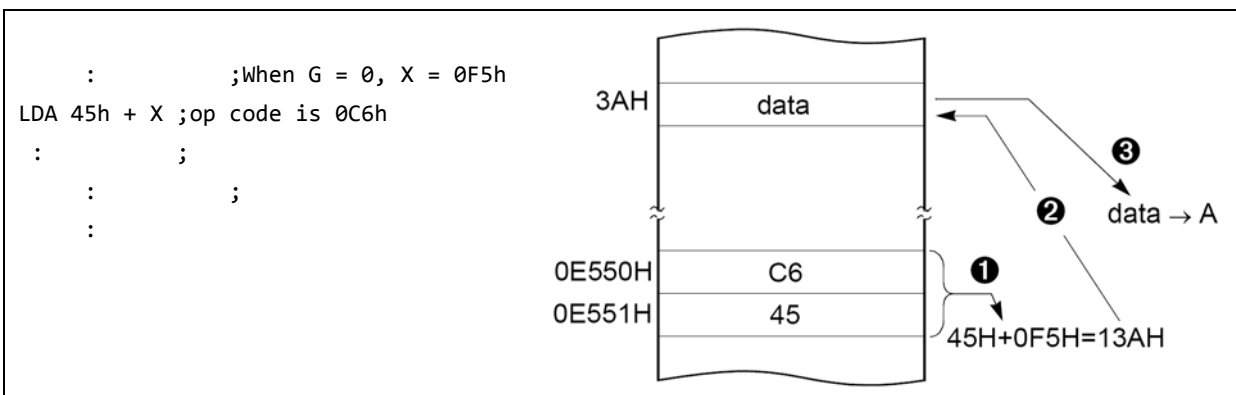

Y indexed direct page (8 bit offset) → dp+Y

This address value is the second byte (Operand) of command plus the data of Y-register, which assigns Memory in Direct page.

This is same with above 'X indexed direct page'. Use Y register instead of X.

Y indexed absolute → !abs+Y

Accessing the value of 16-bit absolute address plus Y-register value. This addressing mode can specify memory in whole area.

Example :

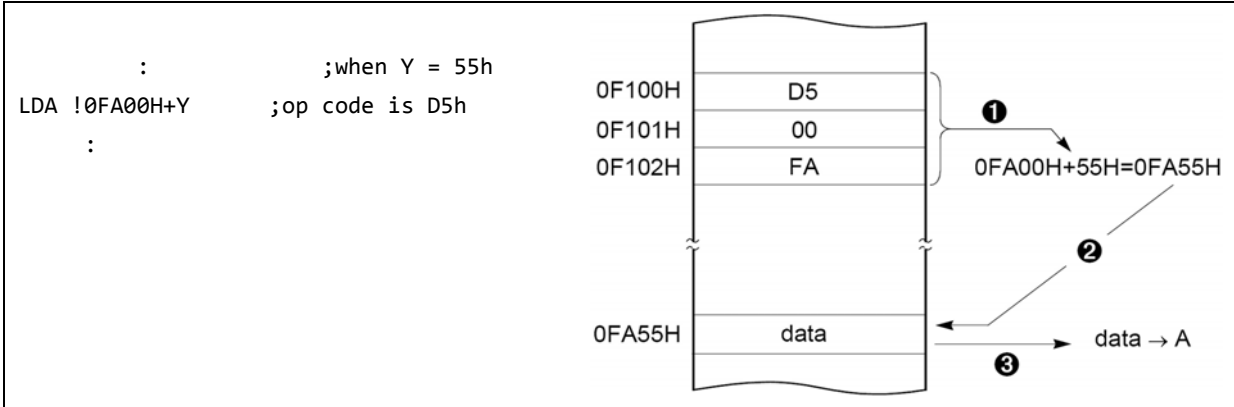

Indirect Addressing

Direct page indirect → [dp]

Assigns data address to use for accomplishing command which sets memory data (or pair memory) by Operand.

Also index can be used with Index register X,Y.

JMP, CALL

Example :

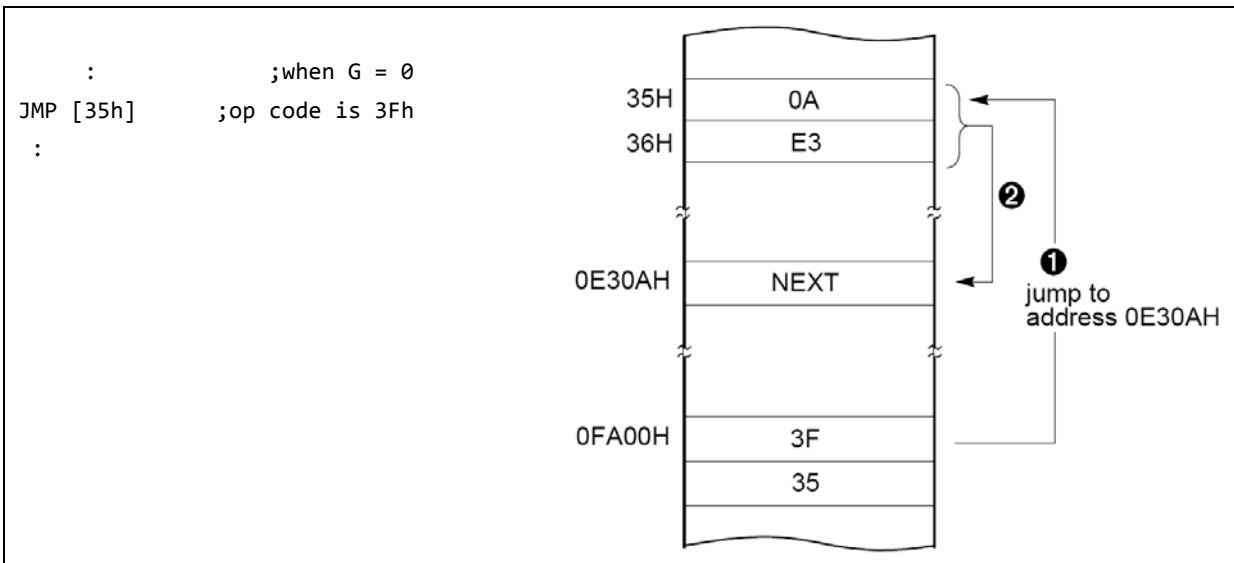

X indexed indirect → [dp+X]

Processes memory data as Data, assigned by 16-bit pair memory which is determined by pair data [dp+X+1][dp+X] Operand plus X-register data in Direct page.

ADC, AND, CMP, EOR, LDA, OR, SBC, STA

Example :

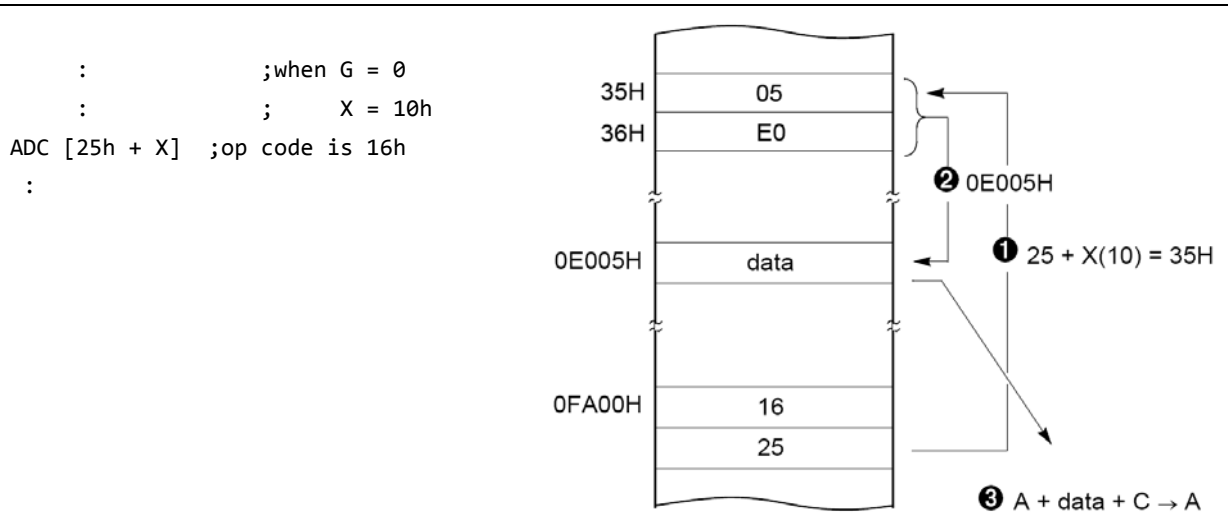

Y indexed indirect → [dp]+Y

Processes memory data as Data, assigned by the data [dp+1][dp] of 16-bit pair memory paired by Operand in Direct page plus Y-register data.

ADC, AND, CMP, EOR, LDA, OR, SBC, STA

Example :

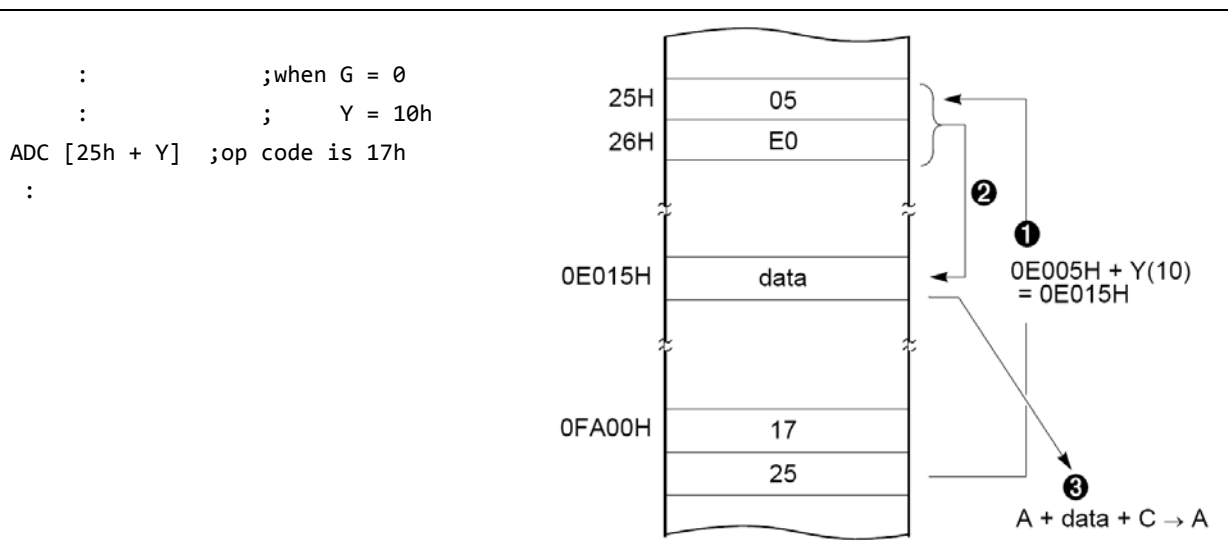

Absolute indirect → [!abs]

The program jumps to address specified by 16-bit absolute address.

JMP

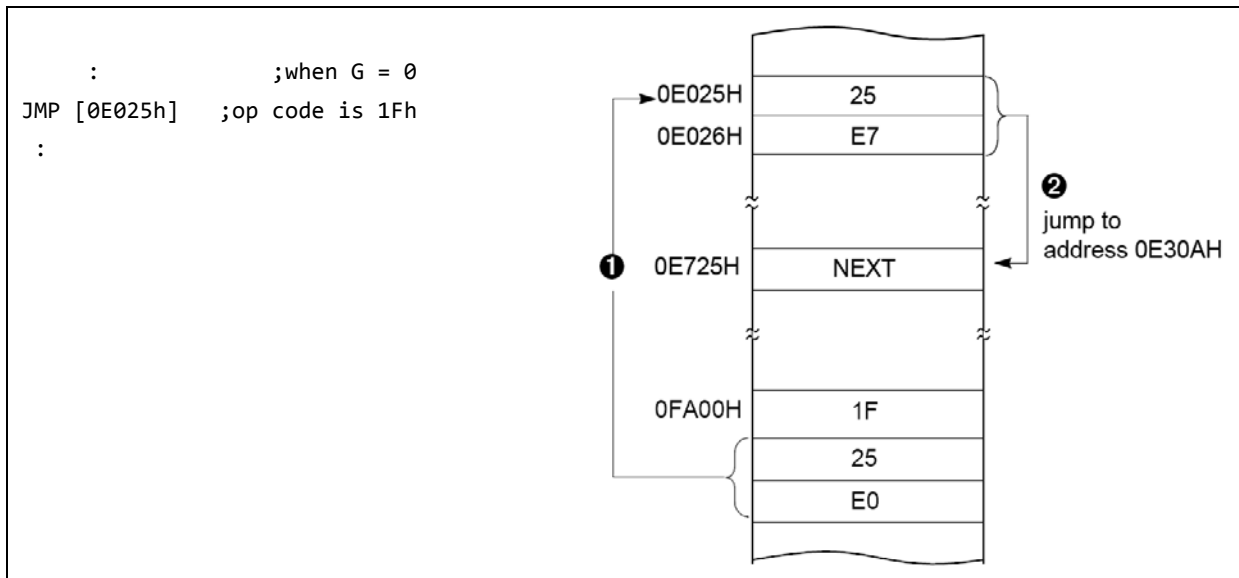
Example :

10. I/O PORTS

The MC81F4x16 microcontroller has six I/O ports, P0-P5. The CPU accesses ports by writing or reading port register directly.

The R0 port has following features,

- 1-bit programmable I/O port.
- Schmitt trigger input, push-pull or open-drain output mode can be selected by software.
- A pull-up resistor can be specified in 1-bit.
- R00-R01 can be used as EXT10/SXin, EXT11/SXout
- R02-R07 can be used as EXT0-EXT5/AD0-AD5
- R02-R03 can be used as EC0, T0O/T0PWM
- R04-R05 can be used as EC1/SCK, T1O/T1PWM/SI
- R06-R07 can be used as EC2/SO, T2O

The R1 port has following features,

- 1-bit programmable I/O port.
- Schmitt trigger input, push-pull or open-drain output mode can be selected by software.
- A pull-up resistor can be specified in 1-bit.
- R10-R13 can be used as EXT6-EXT9/Vref, AN6-AN8
- R11-R13 can be used as PWM2O-PWM4O
- R12 can be used as BUZO
- R14-R17 can be used as RxD, TxD, SDA, SCL

The R2 port has following features,

- 1-bit programmable I/O port.
- Input, push-pull or open-drain output mode can be selected by software.
- A pull-up resistor can be specified in 1-bit.
- R20 can be used as AN9
- R25-R27 can be used as AN10-AN12

The R3 port has following features,

- 1-bit programmable I/O port.
- Schmitt trigger or normal input, push-pull or open-drain output mode can be selected by software.
- R30-R31 can be used as AN13-AN14
- R33-R34 can be used as Xout, Xin
- R35 can be used as RESETB

The R4 port has following features,

- 1-bit programmable I/O port.
- Input, push-pull or open-drain output mode can be selected by software.

The R5 port has following features,

- 1-bit programmable I/O port.
- Input, push-pull or open-drain output mode can be selected by software.

10.1 R0 Port Registers

R0CONH – R05~07

R0 PORT CONTROL HIGH REGISTER

00C6H

A reset clears the R0CONH register to '00H', makes R07-R05 pins input mode. You can use R0CONH register setting to select input or output mode (open-drain or push-pull) and enable alternative functions.

When programming the port, please remember that any alternative peripheral I/O function that defined by the R0CONH register must also be enabled in the associated peripheral module.

	7	6	5	4	3	2	1	0	
R0CONH	R07		R06		-		R05		Reset value: 00H
	R/W	R/W	R/W	R/W	R/W	R/W	-	R/W	

R07	R07/AN5/EXT5/T2O	000: Schmitt trigger input mode(EXT5) 001: Output mode, open-drain 010: Alternative function (AN5) 011: Alternative function (T2O) 1xx: Output mode, push-pull
R06	R06/AN4/EXT4/SO/EC2	000: Schmitt trigger input mode (EC2/EXT4) 001: Output mode, open-drain 010: Alternative function (AN4) 011: Alternative function (SO) 1xx: Output mode, push-pull
-	bit1	Not used for MC81F4x16
R05	R05/AN3/EXT3/SI/T1O/PWM1O	1: Output mode, push-pull 0: depend on R0CONM.7 – .6

Note:
 1. When R0CONH.0 is selected to '1', R05 is push-pull output mode.
 2. When R0CONH.0 is selected to '0', R05 depends on R0CONM.7 - .6 bits.

R0CONM – R03~05

R0 PORT CONTROL MIDDLE REGISTER

00C7H

A reset clears the R0CONM register to '00H', makes R04-R03 pins input mode. You can use R0CONM register setting to select input or output mode (open-drain or push-pull) and enable alternative functions.

When programming the port, please remember that any alternative peripheral I/O function that defined by the R0CONM register must also be enabled in the associated peripheral module.

	7	6	5	4	3	2	1	0	
R0CONM	R05		R04			R03			Reset value: 00H
	R/W	R/W	R/W	R/W	R/W	R/W	R/W	R/W	

R05	R05/AN3/EXT3/SI/T1O/PWM1O	00: Schmitt trigger input mode (SI/EXT3) 01: Output mode, open-drain 10: Alternative function (AN3) 11: Alternative function (T1O/PWM1O)
R04	R04/AN2/EXT2/SCK/EC1	000: Schmitt trigger input mode (*SCK in / EC1 / EXT2) 001: Output mode, open-drain 010: Alternative function (AN2) 011: Alternative function (SCK out) 1xx: Output mode, push-pull
R03	R03/AN1/EXT1/T0O/PWM0O	000: Schmitt trigger input mode(EXT1) 001: Output mode, open-drain 010: Alternative function (AN1) 011: Alternative function (T0O/PWM0O) 1xx: Output mode, push-pull

Note:

If you want to use SIO module in slave mode, you must set SCK port as an input mode.

R0CONL – R00~02

R0 PORT CONTROL LOW REGISTER

00C8H

A reset clears the R0CONL register to '00H', makes R02-R00 pins input mode. You can use R0CONL register setting to select input or output mode (open-drain or push-pull) and enable alternative functions.

When programming the port, please remember that any alternative peripheral I/O function that defined by the R0CONL register must also be enabled in the associated peripheral module.

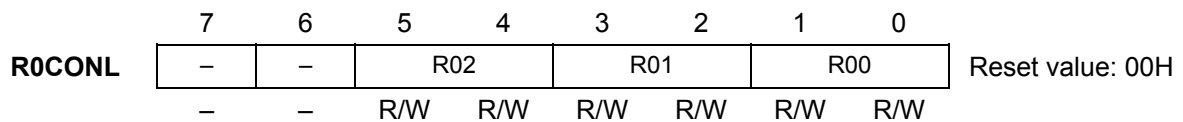

-	bit7 – bit6	Not used for MC81F4x16
R02	R02/AN0/EXT0/EC0	00: Schmitt trigger input mode (EC0/EXT0) 01: Output mode, open-drain 10: Alternative function (AN0) 11: Output mode, push-pull
R01	R01/SXout/EXT11	00: Schmitt trigger input mode(EXT11) 01: Output mode, open-drain 10: Alternative function (SXout) 11: Output mode, push-pull
R00	R00/SXin/EXT10	00: Schmitt trigger input mode(EXT10) 01: Output mode, open-drain 10: Alternative function (SXin) 11: Output mode, push-pull

PUR0

R0 PORT PULL-UP ENABLE REGISTER

00C9H

Using the PUR0 register, you can configure pull-up resistors to individual R07-R00 pins.

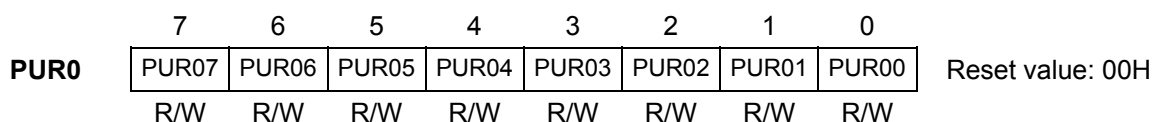

PUR07	R07 Pull-up Resistor Enable Bit	0: Disable pull-up resistor 1: Enable pull-up resistor
PUR06	R06 Pull-up Resistor Enable Bit	0: Disable pull-up resistor 1: Enable pull-up resistor
PUR05	R05 Pull-up Resistor Enable Bit	0: Disable pull-up resistor 1: Enable pull-up resistor
PUR04	R04 Pull-up Resistor Enable Bit	0: Disable pull-up resistor 1: Enable pull-up resistor
PUR03	R03 Pull-up Resistor Enable Bit	0: Disable pull-up resistor 1: Enable pull-up resistor
PUR02	R02 Pull-up Resistor Enable Bit	0: Disable pull-up resistor 1: Enable pull-up resistor
PUR01	R01 Pull-up Resistor Enable Bit	0: Disable pull-up resistor 1: Enable pull-up resistor
PUR00	R00 Pull-up Resistor Enable Bit	0: Disable pull-up resistor 1: Enable pull-up resistor

R0

R0 PORT DATA REGISTER

00C0H

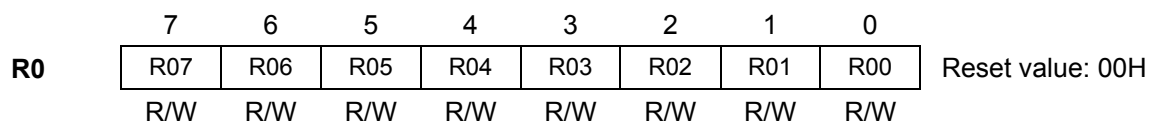

In input mode, it represents the R0 port status. In output mode, R0 port represents it.	1: High 0 : Low
--	--------------------

10.2 R1 Port Registers

R1CONH – R14~R17

R1 PORT CONTROL HIGH REGISTER

00D3H

A reset clears the R1CONH register to '55H', makes the R17-R14 pins to open-drain output mode. You can use R1CONH register setting to select input or output mode (open-drain or push-pull) and enable alternative functions.

When programming the port, please remember that any alternative peripheral I/O function that defined by the R1CONH register must also be enabled in the associated peripheral module.

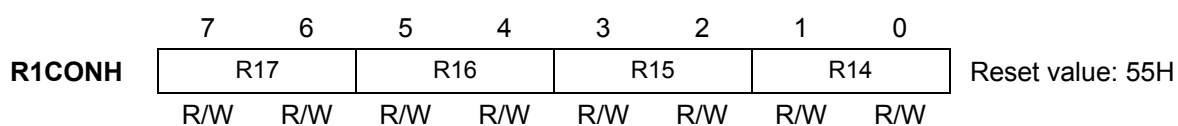

R17	R17/SCL	00: Schmitt trigger input mode 01: Output mode, open-drain 10: Alternative function (SCL) 11: Output mode, push-pull
R16	R16/SDA	00: Schmitt trigger input mode 01: Output mode, open-drain 10: Alternative function (SDA) 11: Output mode, push-pull
R15	R15/TxD	00: Schmitt trigger input mode 01: Output mode, open-drain 10: Alternative function (TxD) 11: Output mode, push-pull
R14	R14/RxD	00: Schmitt trigger input mode (RxD mode1,2,3) 01: Output mode, open-drain 10: Alternative function (RxD mode 0) 11: Output mode, push-pull

R1CONM – R12~R13

R1 PORT CONTROL MIDDLE REGISTER

00D4H

A reset clears the R1CONM register to '20H', makes the R13 pin to open-drain output mode and the R12 pin to input mode. You can use R1CONM register setting to select input or output mode (open-drain or push-pull) and enable alternative functions.

When programming the port, please remember that any alternative peripheral I/O function that defined by the R1CONM register must also be enabled in the associated peripheral module.

	7	6	5	4	3	2	1	0	
R1CONM	R13		R12			-	-		Reset value: 20H
	R/W	R/W	R/W	R/W	R/W	R/W	-	-	

R13	R13/AN8/EXT9/PWM4O	000: Schmitt trigger input mode(EXT9) 001: Output mode, open-drain 010: Alternative function (AN8) 011: Alternative function (PWM4O) 1xx: Output mode, push-pull
R12	R12/AN7/EXT8/PWM3O/BUZO	000: Schmitt trigger input mode(EXT8) 001: Output mode, open-drain 010: Alternative function (AN7) 011: Alternative function (PWM3O) 101: Alternative function (BUZO) 111: Output mode, push-pull Others: Not available
-	bit1 – bit0	Not used for MC81F4x16

R1CONL – R10~11

R1 PORT CONTROL LOW REGISTER

00D5H

A reset clears the R1CONL register to '00H', makes R11-R10 pins input mode. You can use R1CONL register setting to select input or output mode (open-drain or push-pull) and enable alternative functions.

When programming the port, please remember that any alternative peripheral I/O function that defined by the R1CONL register must also be enabled in the associated peripheral module.

	7	6	5	4	3	2	1	0	
R1CONL	-	-	-	R11		R10			Reset value: 00H
	-	-	-	R/W	R/W	R/W	R/W	R/W	

-	bit7 – bit5	Not used for MC81F4x16
R11	R11/AN6/EXT7/PWM2O	000: Schmitt trigger input mode(EXT7) 001: Output mode, open-drain 010: Alternative function (AN6) 011: Alternative function (PWM2O) 1xx: Output mode, push-pull
R10	R10/Vref/EXT6	00: Schmitt trigger input mode(EXT6) 01: Output mode, open-drain 10: Alternative function (Vref) 11: Output mode, push-pull

PUR1

R1 PORT PULL-UP ENABLE REGISTER

00D6H

Using the PUR1 register, you can configure pull-up resistors to individual R17-R10 pins.

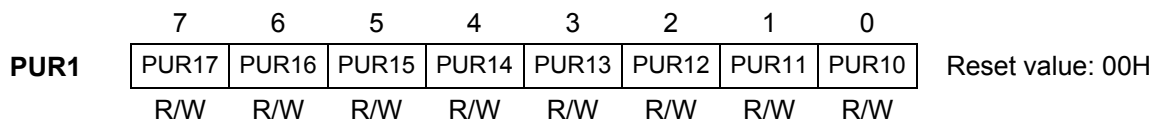

PUR17	R17 Pull-up Resistor Enable Bit	0: Disable pull-up resistor 1: Enable pull-up resistor
PUR16	R16 Pull-up Resistor Enable Bit	0: Disable pull-up resistor 1: Enable pull-up resistor
PUR15	R15 Pull-up Resistor Enable Bit	0: Disable pull-up resistor 1: Enable pull-up resistor
PUR14	R14 Pull-up Resistor Enable Bit	0: Disable pull-up resistor 1: Enable pull-up resistor
PUR13	R13 Pull-up Resistor Enable Bit	0: Disable pull-up resistor 1: Enable pull-up resistor
PUR12	R12 Pull-up Resistor Enable Bit	0: Disable pull-up resistor 1: Enable pull-up resistor
PUR11	R11 Pull-up Resistor Enable Bit	0: Disable pull-up resistor 1: Enable pull-up resistor
PUR10	R10 Pull-up Resistor Enable Bit	0: Disable pull-up resistor 1: Enable pull-up resistor

R1

R1 PORT DATA REGISTER

00C1H

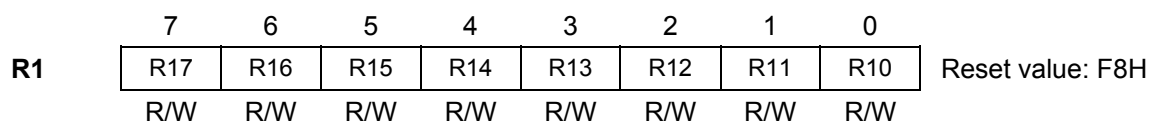

In input mode, it represents the R1 port status. In output mode, R1 port represents it.	1: High 0 : Low
--	--------------------

10.3 R2 Port Registers

R2CONH – R24~R27

R2 PORT CONTROL HIGH REGISTER

00D9H

A reset clears the R2CONH register to '55H', makes the R27-R24 pins to open-drain output mode. You can use R2CONH register setting to select input or output mode (open-drain or push-pull) and enable alternative functions.

When programming the port, please remember that any alternative peripheral I/O function that defined by the R2CONH register must also be enabled in the associated peripheral module.

	7	6	5	4	3	2	1	0	
R2CONH	R27		R26		R25		R24		Reset value: 55H
	R/W	R/W	R/W	R/W	R/W	R/W	R/W	R/W	

R27	R27/AN12	00: Input mode 01: Output mode, open-drain 10: Alternative function (AN12) 11: Output mode, push-pull
R26	R26/AN11	00: Input mode 01: Output mode, open-drain 10: Alternative function (AN11) 11: Output mode, push-pull
R25	R25/AN10	00: Input mode 01: Output mode, open-drain 10: Alternative function (AN10) 11: Output mode, push-pull
R24	R24	00: Input mode 01: Output mode, open-drain 10: Not available 11: Output mode, push-pull

R2CONL – R20~R23

R2 PORT CONTROL LOW REGISTER

00DAH

A reset clears the R2CONL register to '55H', makes R23-R20 pins to open-drain output mode. You can use R2CONL register setting to select input or output mode (open-drain or push-pull) and enable alternative functions.

When programming the port, please remember that any alternative peripheral I/O function that defined by the R2CONL register must also be enabled in the associated peripheral module.

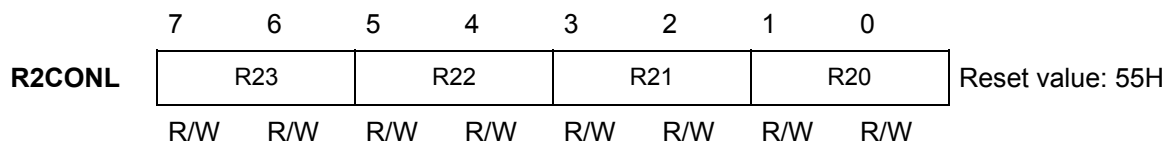

R23	R23	00: Input mode 01: Output mode, open-drain 10: Not available 11: Output mode, push-pull
R22	R22	00: Input mode 01: Output mode, open-drain 10: Not available 11: Output mode, push-pull
R21	R21	00: Input mode 01: Output mode, open-drain 10: Not available 11: Output mode, push-pull
R20	R20/AN9	00: Input mode 01: Output mode, open-drain 10: Alternative function (AN9) 11: Output mode, push-pull

PUR2

R2 PORT PULL-UP ENABLE REGISTER

00DBH

Using the PUR2 register, you can configure pull-up resistors to individual R27-R20 pins.

PUR2	7	6	5	4	3	2	1	0	Reset value: 00H
	PUR27	PUR26	PUR25	PUR24	PUR23	PUR22	PUR21	PUR20	
	R/W	R/W	R/W	R/W	R/W	R/W	R/W	R/W	

PUR27	R27 Pull-up Resistor Enable Bit	0: Disable pull-up resistor 1: Enable pull-up resistor
PUR26	R26 Pull-up Resistor Enable Bit	0: Disable pull-up resistor 1: Enable pull-up resistor
PUR25	R25 Pull-up Resistor Enable Bit	0: Disable pull-up resistor 1: Enable pull-up resistor
PUR24	R24 Pull-up Resistor Enable Bit	0: Disable pull-up resistor 1: Enable pull-up resistor
PUR23	R23 Pull-up Resistor Enable Bit	0: Disable pull-up resistor 1: Enable pull-up resistor
PUR22	R22 Pull-up Resistor Enable Bit	0: Disable pull-up resistor 1: Enable pull-up resistor
PUR21	R21 Pull-up Resistor Enable Bit	0: Disable pull-up resistor 1: Enable pull-up resistor
PUR20	R20 Pull-up Resistor Enable Bit	0: Disable pull-up resistor 1: Enable pull-up resistor

R2

R2 PORT DATA REGISTER

00C2H

R2	7	6	5	4	3	2	1	0	Reset value: FFH
	R27	R26	R25	R24	R23	R22	R21	R20	
	R/W	R/W	R/W	R/W	R/W	R/W	R/W	R/W	

In input mode, it represents the R2 port status. In output mode, R2 port represents it.	1: High 0 : Low
--	--------------------

10.4 R3 Port Registers

R3CONH – R33~R35

R3 PORT CONTROL HIGH REGISTER

00DCH

A reset clears the R3CONH register to '00H', makes R35-R33 pins input mode. You can use R3CONH register setting to select input or output mode (open-drain or push-pull) and enable alternative functions.

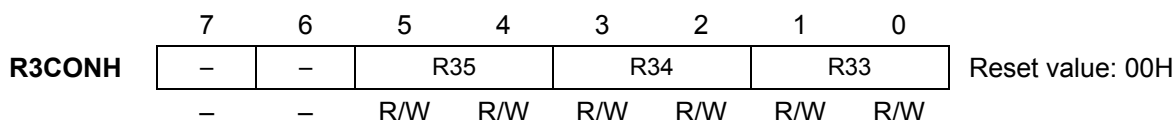

–	bit7 – bit6	Not used for MC81F4x16
R35	R35/RESETB (*note*)	00: Schmitt trigger input mode 01: Not available 10: Output mode, open-drain 11: Not available
R34	R34/Xin (*note*)	00: Schmitt trigger input mode 01: Schmitt trigger input pull-up mode 10: Output mode, open-drain 11: Output mode, push-pull
R33	R33/Xout (*note*)	00: Schmitt trigger input mode 01: Schmitt trigger input pull-up mode 10: Output mode, open-drain 11: Output mode, push-pull

If you want to use RESETB, the LVREN (ROM OPTION [7]) must select to LVR disable mode ('1'). If you want to use R35, the LVREN (ROM OPTION [7]) must be selected to LVR enable mode ('0').

If you want to use X_{IN} and X_{OUT}, the OSCS (ROM OPTION [2:0]) must select to Crystal/ceramic oscillator mode (11b). If you want to use R33 and R34, the OSCS (ROM OPTION [2:0]) must select to Internal RC mode (001b, 010b, 011b, 100b).

Even you are in case of using emulator you must select the ROM OPTION switch properly to use those R33,R34,R35 ports.

R3CONL – R30~R32

R3 PORT CONTROL LOW REGISTER

00DDH

A reset clears the R3CONL register to '9BH', makes the R32-R30 pins to open-drain output mode. You can use R3CONL register setting to select input or output mode (open-drain or push-pull) and enable alternative functions.

When programming the port, please remember that any alternative peripheral I/O function that defined by the R3CONL register must also be enabled in the associated peripheral module.

	7	6	5	4	3	2	1	0	
R3CONL	R32		R31			R30			Reset value: 9BH
	R/W	R/W	R/W	R/W	R/W	R/W	R/W	R/W	

R32	R32	00: Input mode 01: Input pull-up mode 10: Output mode, open-drain 11: Output mode, push-pull
R31	R31/AN14	000: Input mode 001: Input pull-up mode 010: Alternative function (AN14) 011: Output mode, open-drain 1xx: Output mode, push-pull
R30	R30/AN13	000: Input mode 001: Input pull-up mode 010: Alternative function (AN13) 011: Output mode, open-drain 1xx: Output mode, push-pull

R3

R3 PORT DATA REGISTER

00C3H

	7	6	5	4	3	2	1	0	
R3	R37	R36	R35	R34	R33	R32	R31	R30	Reset value: --00_0111b
	R/W	R/W	R/W	R/W	R/W	R/W	R/W	R/W	

In input mode, it represents the R3 port status. In output mode, R3 port represents it.	1: High 0 : Low
--	--------------------

10.5 R4 Port Registers

R4CONH – R44~R47

R4 PORT CONTROL HIGH REGISTER

00DEH

A reset clears the R4CONH register to 'AAH', makes the R47-R44 pins to open-drain output mode. You can use R4CONH register setting to select input (with or without pull-up) or output mode (open-drain or push-pull).

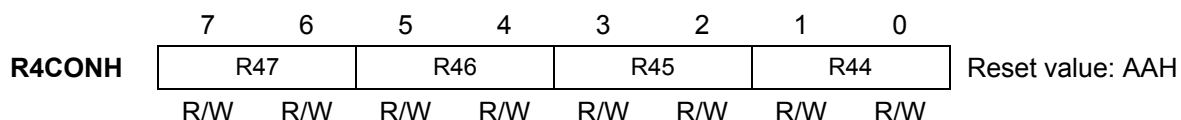

R47	R47	00: Input mode 01: Input pull-up mode 10: Output mode, open-drain 11: Output mode, push-pull
R46	R46	00: Input mode 01: Input pull-up mode 10: Output mode, open-drain 11: Output mode, push-pull
R45	R45	00: Input mode 01: Input pull-up mode 10: Output mode, open-drain 11: Output mode, push-pull
R44	R44	00: Input mode 01: Input pull-up mode 10: Output mode, open-drain 11: Output mode, push-pull

R4CONL – R40~R43

R4 PORT CONTROL LOW REGISTER

00DFH

A reset clears the R4CONL register to 'AAH', makes the R43-R40 pins to open drain output mode. You can use R4CONL register setting to select input (with or without pull-up) or output mode (open-drain or push-pull) .

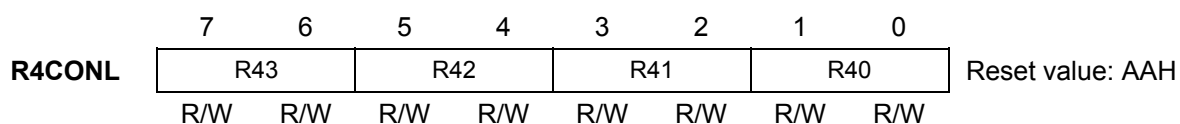

R43	R43	00: Input mode 01: Input pull-up mode 10: Output mode, open-drain 11: Output mode, push-pull
R42	R42	00: Input mode 01: Input pull-up mode 10: Output mode, open-drain 11: Output mode, push-pull
R41	R41	00: Input mode 01: Input pull-up mode 10: Output mode, open-drain 11: Output mode, push-pull
R40	R40	00: Input mode 01: Input pull-up mode 10: Output mode, open-drain 11: Output mode, push-pull

R4

R4 PORT DATA REGISTER

00C4H

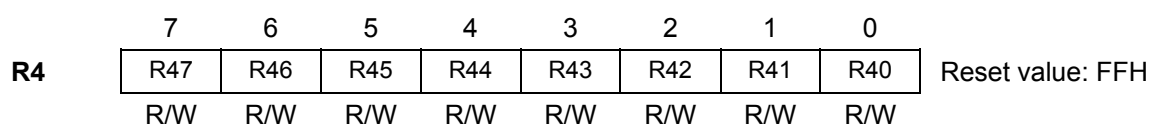

In input mode, it represents the R4 port status. In output mode, R4 port represents it.	1: High 0 : Low
--	--------------------

10.6 R5 Port

R5CON – R50~R53

R5 PORT CONTROL REGISTER

00E0H

A reset clears the R5CON register to 'AAH', makes R53-R50 pins to open-drain output mode. You can use R5CON register setting to select input (with or without pull-up) or output mode (open-drain or push-pull).

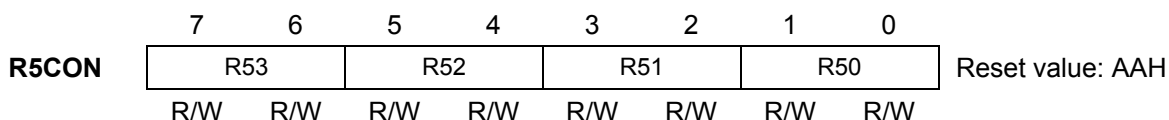

R53	R53	00: Input mode 01: Input pull-up mode 10: Output mode, open-drain 11: Output mode, push-pull
R52	R52	00: Input mode 01: Input pull-up mode 10: Output mode, open-drain 11: Output mode, push-pull
R51	R51	00: Input mode 01: Input pull-up mode 10: Output mode, open-drain 11: Output mode, push-pull
R50	R50	00: Input mode 01: Input pull-up mode 10: Output mode, open-drain 11: Output mode, push-pull

R5

R5 PORT DATA REGISTER

00C5H

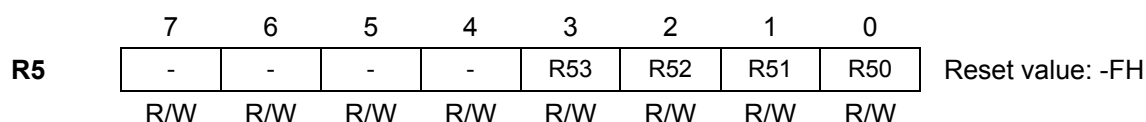

In input mode, it represents the R5 port status. In output mode, R5 port represents it.	1: High 0 : Low
--	--------------------

11. INTERRUPT CONTROLLER

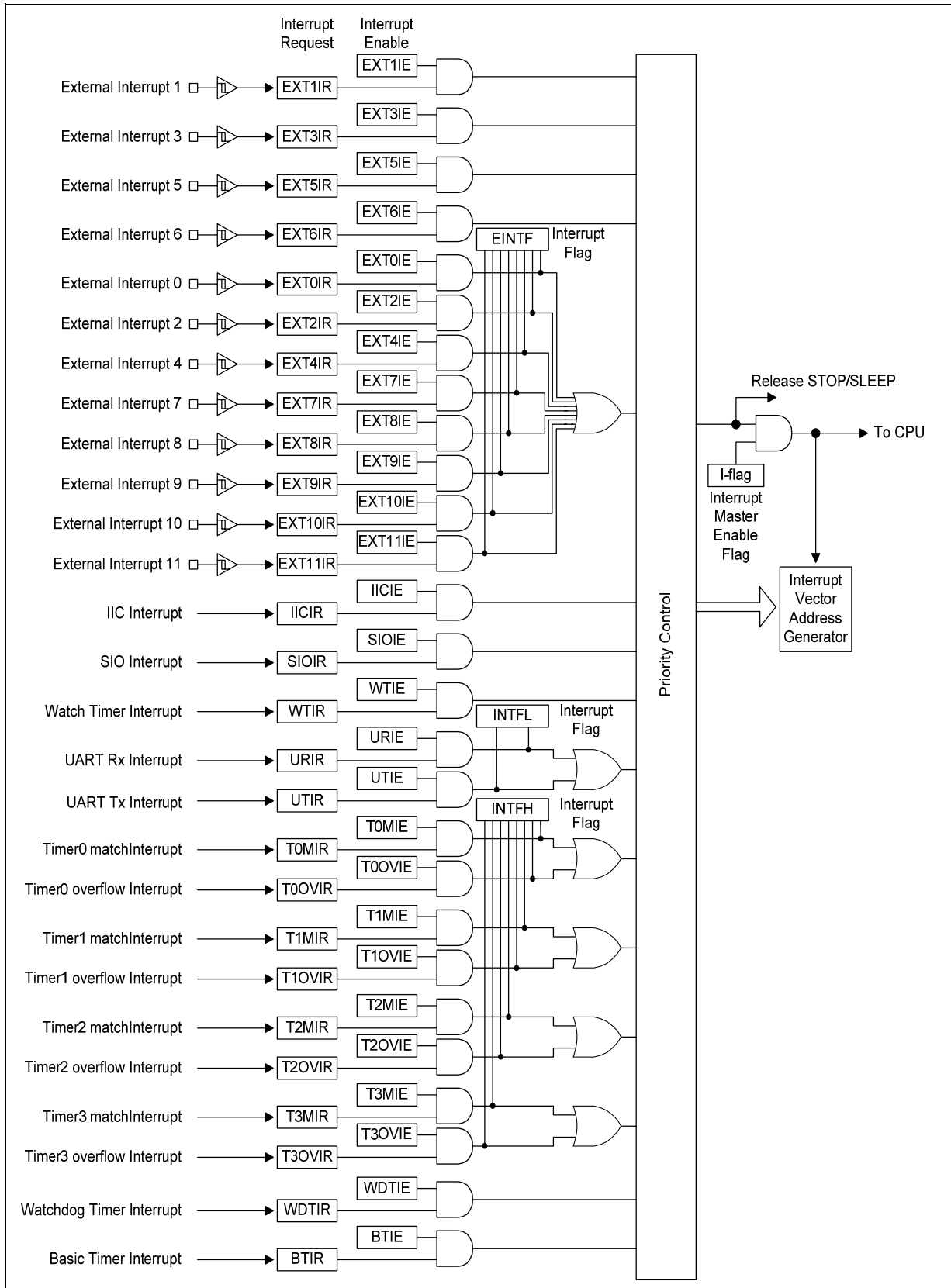

Figure 11-1 Block Diagram of Interrupt

The MC81F4x16 interrupt circuits consist of Interrupt enable register (IENH, IENL), Interrupt request flags of IRQH, IRQL, Priority circuit, and Master enable flag (“I” flag of PSW). And 27 interrupt sources are provided.

The interrupt vector addresses are shown in ‘11.6 Interrupt Vector & Priority Table’ on page 112. Interrupt enable registers are shown in next paragraph. These registers are composed of interrupt enable flags of each interrupt source and these flags determine whether an interrupt will be accepted or not. When the enable flag is “0”, a corresponding interrupt source is disabled.

Note that PSW contains also a master enable bit, I-flag, which disables all interrupts at once.

11.1 Registers

IENH

INTERRUPT ENABLE HIGH REGISTER

00EAH

	7	6	5	4	3	2	1	0	
IENH	T0MIE	T0OVIE	T1MIE	T1OVIE	T2MIE	T2OVIE	T3MIE	T3OVIE	Reset value: 00H
	R/W	R/W	R/W	R/W	R/W	R/W	R/W	R/W	

T0MIE	Timer 0 Match Interrupt Enable Bit	0: Disable interrupt 1: Enable interrupt
T0OVIE	Timer 0 Overflow Interrupt Enable Bit	0: Disable interrupt 1: Enable interrupt
T1MIE	Timer 1 Match Interrupt Enable Bit	0: Disable interrupt 1: Enable interrupt
T1OVIE	Timer 1 Overflow Interrupt Enable Bit	0: Disable interrupt 1: Enable interrupt
T2MIE	Timer 2 Match Interrupt Enable Bit	0: Disable interrupt 1: Enable interrupt
T2OVIE	Timer 2 Overflow Interrupt Enable Bit	0: Disable interrupt 1: Enable interrupt
T3MIE	Timer 3 Match Interrupt Enable Bit	0: Disable interrupt 1: Enable interrupt
T3OVIE	Timer 3 Overflow Interrupt Enable Bit	0: Disable interrupt 1: Enable interrupt

IENL

INTERRUPT ENABLE LOW REGISTER

00EBH

	7	6	5	4	3	2	1	0	
IENL	IICIE	SIOIE	WTIE	URIE	UTIE	WDTIE	–	BTIE	Reset value: 00H
	R/W	R/W	R/W	R/W	R/W	R/W	–	R/W	

IICIE	IIC Interrupt Enable Bit	0: Disable interrupt 1: Enable interrupt
SIOIE	SIO Interrupt Enable Bit	0: Disable interrupt 1: Enable interrupt
WTIE	Watch Timer Interrupt Enable Bit	0: Disable interrupt 1: Enable interrupt
URIE	UART Rx Interrupt Enable Bit	0: Disable interrupt 1: Enable interrupt
UTIE	UART Tx Interrupt Enable Bit	0: Disable interrupt 1: Enable interrupt
WDTIE	Watchdog Timer Interrupt Enable Bit	0: Disable interrupt 1: Enable interrupt
–	bit1	Not used for MC81F4x16
BTIE	Basic Timer Interrupt Enable Bit	0: Disable interrupt 1: Enable interrupt

IRQH**INTERRUPT REQUEST HIGH REGISTER****00ECH**

7	6	5	4	3	2	1	0
---	---	---	---	---	---	---	---

IQRH T0MIR T0OVIR T1MIR T1OVIR T2MIR T2OVIR T3MIR T3OVIR Reset value: 00H
 R/W R/W R/W R/W R/W R/W R/W R/W

T0MIR	Timer 0 Match Interrupt Request Flag	0: Interrupt request flag is not pending, request flag bit clear 1: Interrupt request flag is pending
T0OVIR	Timer 0 Overflow Interrupt Request Flag	0: Interrupt request flag is not pending, request flag bit clear 1: Interrupt request flag is pending
T1MIR	Timer 1 Match Interrupt Request Flag	0: Interrupt request flag is not pending, request flag bit clear 1: Interrupt request flag is pending
T1OVIR	Timer 1 Overflow Interrupt Request Flag	0: Interrupt request flag is not pending, request flag bit clear 1: Interrupt request flag is pending
T2MIR	Timer 2 Match Interrupt Request Flag	0: Interrupt request flag is not pending, request flag bit clear 1: Interrupt request flag is pending
T2OVIR	Timer 2 Overflow Interrupt Request Flag	0: Interrupt request flag is not pending, request flag bit clear 1: Interrupt request flag is pending
T3MIR	Timer 3 Match Interrupt Request Flag	0: Interrupt request flag is not pending, request flag bit clear 1: Interrupt request flag is pending
T3OVIR	Timer 3 Overflow Interrupt Request Flag	0: Interrupt request flag is not pending, request flag bit clear 1: Interrupt request flag is pending

IRQL

INTERRUPT REQUESEST LOW REGISTER

00EDH

7 6 5 4 3 2 1 0

IRQL	IICIR	SIOIR	WTIR	URIR	UTIR	WDTIR	–	BITIR	Reset value: 00H
	R/W	R/W	R/W	R/W	R/W	R/W	–	R/W	

IICIR	IIC Interrupt Request Flag	0: Interrupt request flag is not pending, request flag bit clear 1: Interrupt request flag is pending
SIOIR	SIO Interrupt Request Flag	0: Interrupt request flag is not pending, request flag bit clear 1: Interrupt request flag is pending
WTIR	Watch Timer Interrupt Request Flag	0: Interrupt request flag is not pending, request flag bit clear 1: Interrupt request flag is pending
URIR	UART Rx Interrupt Request Flag	0: Interrupt request flag is not pending, request flag bit clear 1: Interrupt request flag is pending
UTIR	UART Tx Interrupt Request Flag	0: Interrupt request flag is not pending, request flag bit clear 1: Interrupt request flag is pending
WDTIR	Watchdog Timer Interrupt Request Flag	0: Interrupt request flag is not pending, request flag bit clear 1: Interrupt request flag is pending
–	bit1	Not used for MC81F4x16
BTIR	Basic Timer Interrupt Request Flag	0: Interrupt request flag is not pending, request flag bit clear 1: Interrupt request flag is pending

INTFH**INTERRUPT FLAG HIGH REGISTER****00EEH**

7 6 5 4 3 2 1 0

INTFH T0MIF | T0OVIF | T1MIF | T1OVIF | T2MIF | T2OVIF | T3MIF | T3OVIF Reset value: 00H
 R/W R/W R/W R/W R/W R/W R/W R/W

T0MIF	Timer 0 Match Interrupt Flag Bit	0: No generation 1: Generation
T0OVIF	Timer 0 Overflow Interrupt Flag Bit	0: No generation 1: Generation
T1MIF	Timer 1 Match Interrupt Flag Bit	0: No generation 1: Generation
T1OVIF	Timer 1 Overflow Interrupt Flag Bit	0: No generation 1: Generation
T2MIF	Timer 2 Match Interrupt Flag Bit	0: No generation 1: Generation
T2OVIF	Timer 2 Overflow Interrupt Flag Bit	0: No generation 1: Generation
T3MIF	Timer 3 Match Interrupt Flag Bit	0: No generation 1: Generation
T3OVIF	Timer 3 Overflow Interrupt Flag Bit	0: No generation 1: Generation

INTFL

INTERRUPT FLAG LOW REGISTER

00EFH

 7 6 5 4 3 2 1 0
INTFL IICIF | – | – | – | – | – | URIF | UTIF Reset value: 00H
 R/W – – – – – R/W R/W

IICIF	IIC Interrupt Flag Bit	0: No generation 1: Generation
–	bit6 – bit2	Not used for MC81F4x16
URIF	UART Rx Interrupt Flag Bit	0: No generation 1: Generation
UTIF	UART Tx Interrupt Flag Bit	0: No generation 1: Generation

Note:
 When you use 'Shard Interrupt Vector', those INTFH and INTFL are used to recognize which interrupt is generated. See '11.4 Shared Interrupt Vector' on page 110 for more information.

11.2 Interrupt Sequence

An interrupt request is held until the interrupt is accepted or the interrupt latch is cleared to “0” by a reset or an instruction. Interrupt acceptance sequence requires 8 cycles of fXIN (1 μ s at fXIN=4MHz) after the completion of the current instruction execution. The interrupt service task is terminated upon execution of an interrupt return instruction [RETI].

Interrupt acceptance

1. The interrupt master enable flag (I-flag) is cleared to “0” to temporarily disable the acceptance of any following maskable interrupts. When a non-maskable interrupt is accepted, the acceptance of any following interrupts is temporarily disabled.
2. Interrupt request flag for the interrupt source accepted is cleared to “0”.
3. The contents of the program counter (return address) and the program status word are saved (pushed) onto the stack area. The stack pointer decreases 3 times.
4. The entry address of the interrupt service program is read from the vector table address and the entry address is loaded to the program counter.
5. The instruction stored at the entry address of the interrupt service program is executed.

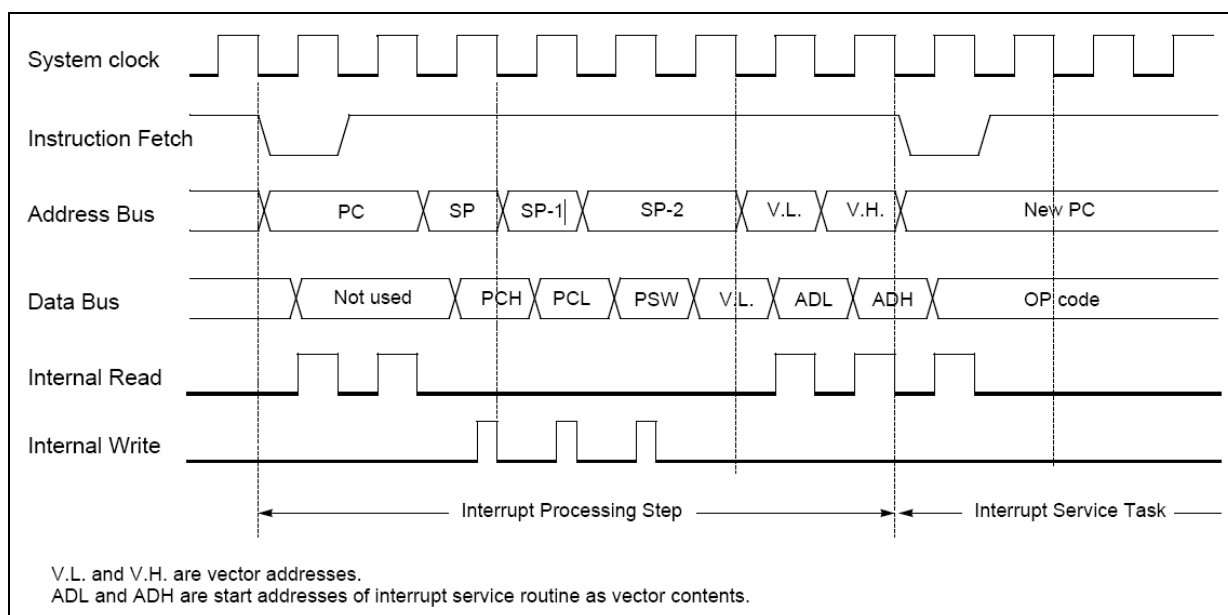

Figure 11-2 Timing chart of Interrupt Acceptance and Interrupt Return Instruction

A interrupt request is not accepted until the I-flag is set to “1” even if a requested interrupt has higher priority than that of the current interrupt being serviced. When nested interrupt service is required, the I-flag should be set to “1” by “EI” instruction in the interrupt service program. In this case, acceptable interrupt sources are selectively enabled by the individual interrupt enable flags.

Saving/Restoring the general-purpose registers

The program status word are automatically saved on the stack, but accumulator and other registers are not saved itself. These registers are saved by the software if necessary. Also, when multiple interrupt services are nested, it is necessary to avoid using the same data memory area for saving registers.

The following method is used to save/restore the general-purpose registers.

Example: Register save using push and pop instructions.

```

INTxx :
PUSH A
PUSH X
PUSH Y
;SAVE XCC.
;SAVE X REG.
;SAVE Y REG.

;; interrupt processing ;;

POP Y
POP X
POP A
RETI
;RESTORE Y REG.
;RESTORE X REG.
;RESTORE ACC.
;RETURN
    
```

General-purpose register save/restore using push and pop instructions;

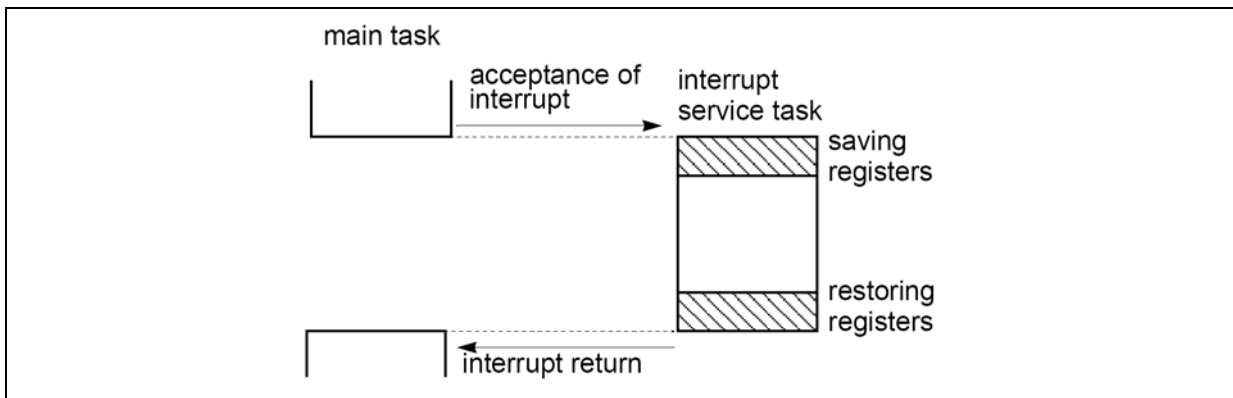
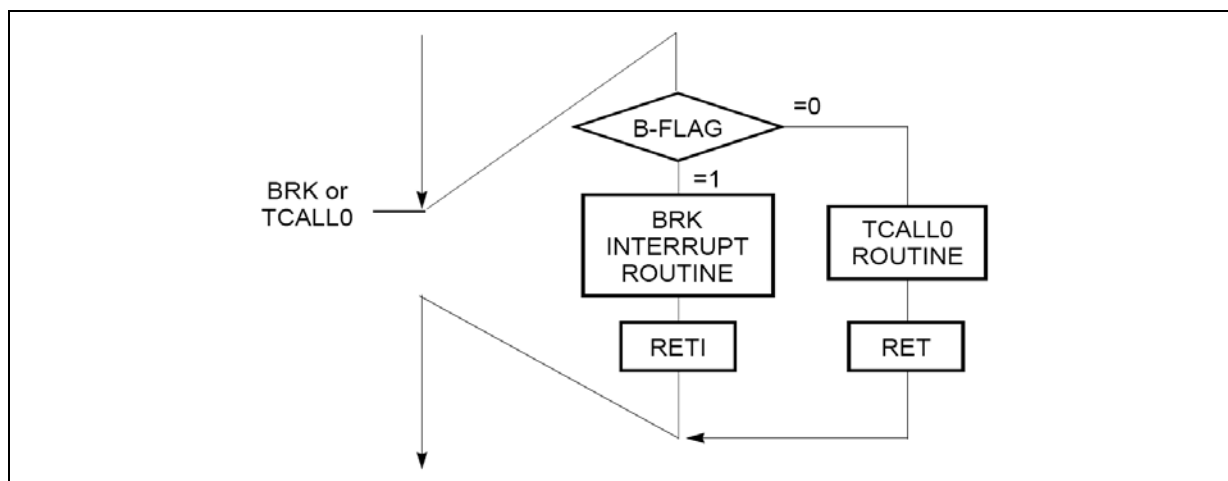

Figure 11-3 Saving/Restoring in Interrupt Routine

11.3 BRK Interrupt

Software interrupt can be invoked by BRK instruction, which has the lowest priority order. Interrupt vector address of BRK is shared with the vector of TCALL 0 (Refer to Program Memory Section). When BRK interrupt is generated, B-flag of PSW is set to distinguish BRK from TCALL 0.

Each processing step is determined by B-flag as shown in Figure



11.4 Shared Interrupt Vector

Some interrupts share the interrupt vector address. To recognize which interrupt is occurred, some interrupt flag registers are used.

Note that, interrupt request bits are cleared after call the interrupt service routine. So interrupt request bits can not be used to recognize which interrupt is occurred.

UART

In case of using interrupts of UART Tx and UART Rx together, it is necessary to check UTIF and URIF in the interrupt service routine to find out which interrupt is occurred. Because the UART Tx and UART Rx share the one interrupt vector address. These flag bits must be cleared by software after reading this register. (UTIF and URIF are placed in INTFL register)

External Interrupt Group

In case of using interrupts of Ext group. It is necessary to check the EINTF register in the interrupt service routine to find out which external interrupt is occurred. Because the 8 external interrupts share the one interrupt vector address. These flag bits must be cleared by software after reading this register.

Timer match / overflow

In case of using interrupts of Timer match and overflow together, it is necessary to check the INTFH register in the interrupt service routine to find out which interrupt is occurred. Because the timer match and overflow share the one interrupt vector address. See 'INTFH' on page 106 to know which bit is which.

11.5 Multi Interrupt

If two requests of different priority levels are received simultaneously, the request of higher priority level is serviced. If requests of the interrupt are received at the same time simultaneously, an internal polling sequence determines by hardware which request is serviced. However, multiple processing through software for special features is possible. Generally when an interrupt is accepted, the I-flag is cleared to disable any further interrupt. But as user sets I-flag in interrupt routine, some further interrupt can be serviced even if certain interrupt is in progress.

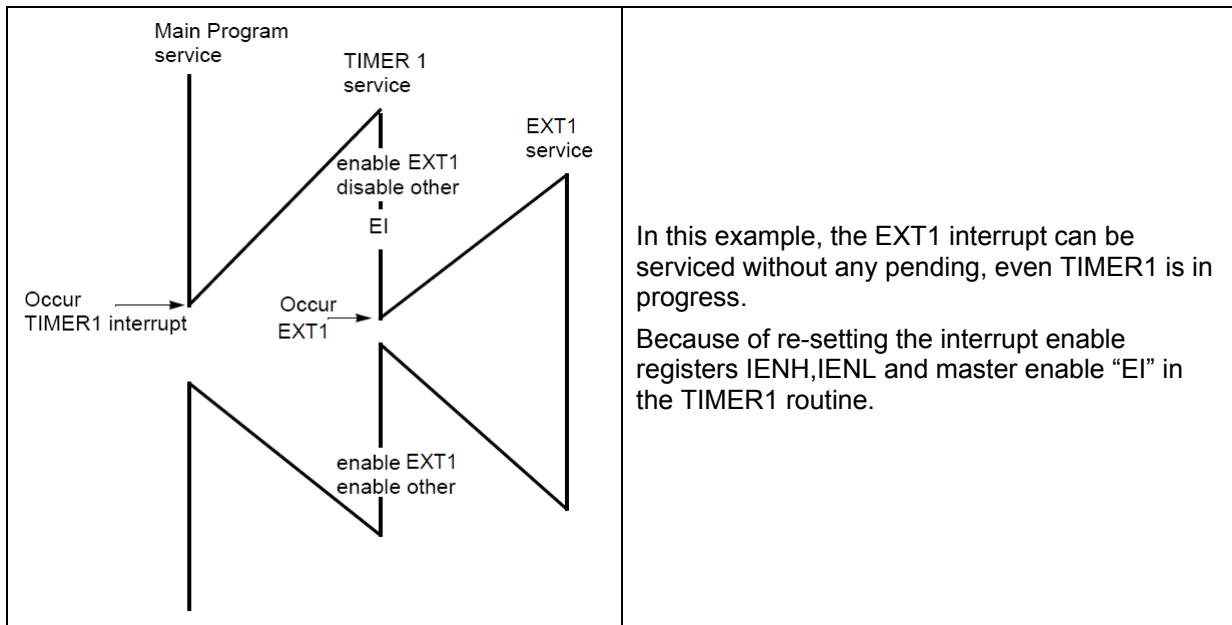

In this example, the EXT1 interrupt can be serviced without any pending, even TIMER1 is in progress. Because of re-setting the interrupt enable registers IENH,IENL and master enable "EI" in the TIMER1 routine.

Figure 11-4 Execution of Multi Interrupt

11.6 Interrupt Vector & Priority Table

Address	Interrupt	INT number	Priority
0FFE0H	Basic Interval Timer	INT0	15 (lowest priority)
0FFE2H	Watchdog Timer	INT1	14
0FFE4H	Timer 3 match/overflow	INT2	13
0FFE6H	Timer 2 match/overflow	INT3	12
0FFE8H	Timer 1 match/overflow	INT4	11
0FFEAH	Timer 0 match/overflow	INT5	10
0FFECH	UART Rx/Tx	INT6	9
0FEEH	Watch Timer	INT7	8
0FFF0H	SIO	INT8	7
0FFF2H	IIC	INT9	6
0FFF4H	External Group	INT10	5
0FFF6H	External 6	INT11	4
0FFF8H	External 5	INT12	3
0FFFAH	External 3	INT13	2
0FFFCH	External 1	INT14	1
0FFFEH	RESET	INT15	0 (highest priority)

Table 11-1 Interrupt Vector & Priority

Note : External Interrupt Group = (EXT0, EXT2, EXT4, EXT7 – EXT11)

12. EXTERNAL INTERRUPTS

The external interrupt pins are edge triggered depending on the 'external interrupt registers'.

The edge detection of external interrupt has three transition activated mode: rising edge, falling edge, and both edge.

12.1 Registers

EINT0H – EXT 2~5 / R04~R07

R0 PORT EXTERNAL INTERRUPT ENABLE HIGH REGISTER

00CAH

A reset clears the EINT0H register to '00H', disables EXT5-EXT2 interrupt. You can use EINT0H register setting to select Disable interrupt or Enable interrupt (by falling, rising, or both falling and rising edge).

EINT0H	7	6	5	4	3	2	1	0	Reset value: 00H
	EXT5IE	EXT4IE	EXT3IE	EXT2IE	R/W	R/W	R/W	R/W	

EXT5IE	R07/EXT5 External Interrupt Enable Bits	00: Disable Interrupt
EXT4IE	R06/EXT4 External Interrupt Enable Bits	01: Enable Interrupt by falling edge
EXT3IE	R05/EXT3 External Interrupt Enable Bits	10: Enable Interrupt by rising edge
EXT2IE	R04/EXT2 External Interrupt Enable Bits	11: Enable Interrupt by both falling and rising edge

EINT0L – EXT 10,11,0,1 / R00~R03

R0 PORT EXTERNAL INTERRUPT ENABLE LOW REGISTER

00CBH

A reset clears the EINT0L register to '00H', disables EXT1-EXT0, EXT11-EXT10 interrupt. You can use EINT0L register setting to select Disable interrupt or Enable interrupt (by falling, rising, or both falling and rising edge).

EINT0L	7	6	5	4	3	2	1	0	Reset value: 00H
	EXT1IE	EXT0IE	EXT11IE	EXT10IE	R/W	R/W	R/W	R/W	

EXT1IE	R03/EXT1 External Interrupt Enable Bits	00: Disable Interrupt
EXT0IE	R02/EXT0 External Interrupt Enable Bits	01: Enable Interrupt by falling edge
EXT11IE	R01/EXT11 External Interrupt Enable Bits	10: Enable Interrupt by rising edge
EXT10IE	R00/EXT10 External Interrupt Enable Bits	11: Enable Interrupt by both falling and rising edge

EINT1 – EXT 6~9 / R10~R13**R1 PORT EXTERNAL INTERRUPT ENABLE REGISTER****00D7H**

A reset clears the EINT1 register to '00H', disables EXT9-EXT6 interrupts. You can use EINT1 register setting to select Disable interrupt or Enable interrupt (by falling, rising, or both falling and rising edge).

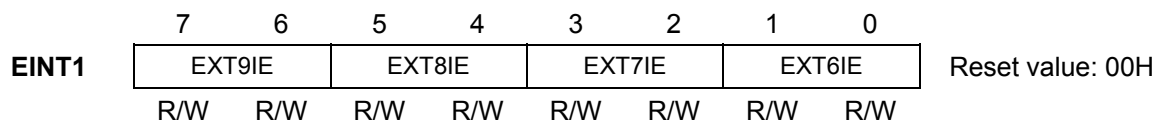

EXT9IE	R13/EXT9 External Interrupt Enable Bits	00: Disable Interrupt
EXT8IE	R12/EXT8 External Interrupt Enable Bits	01: Enable Interrupt by falling edge
EXT7IE	R11/EXT7 External Interrupt Enable Bits	10: Enable Interrupt by rising edge
EXT6IE	R10/EXT6 External Interrupt Enable Bits	11: Enable Interrupt by both falling and rising edge

ERQ0 – EXT 10,11,0~5 / R00~R07

R0 PORT EXTERNAL INTERRUPT REQUEST REGISTER

00CCH

When an interrupt is generated, the bit of ERQ0 that generated it is cleared by the hardware when the service routine is vectored to only if the interrupt was transition-activated.

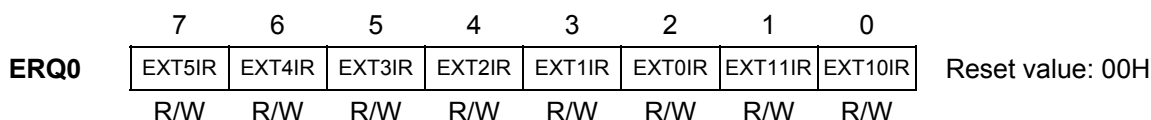

EXT5IR	R07/EXT5 External Interrupt Request Flag	0: Interrupt request flag is not pending, request flag bit clear 1: Interrupt request flag is pending
EXT4IR	R06/EXT4 External Interrupt Request Flag	
EXT3IR	R05/EXT3 External Interrupt Request Flag	
EXT2IR	R04/EXT2 External Interrupt Request Flag	
EXT1IR	R03/EXT1 External Interrupt Request Flag	
EXT0IR	R02/EXT0 External Interrupt Request Flag	
EXT11IR	R01/EXT11 External Interrupt Request Flag	
EXT10IR	R00/EXT10 External Interrupt Request Flag	

ERQ1 – EXT 6~9 / R10~R13

R1 PORT EXTERNAL INTERRUPT REQUEST REGISTER

00D8H

When an interrupt is generated, the bit of ERQ1 that generated it is cleared by the hardware when the service routine is vectored to only if the interrupt was transition-activated.

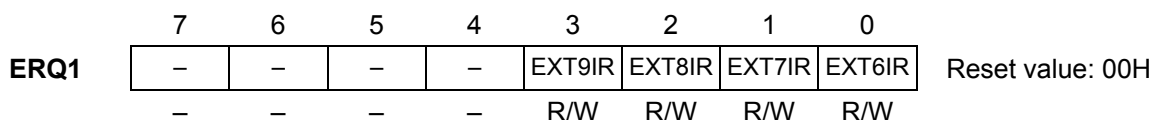

-	bit7 – bit4	Not used for MC81F4x16
EXT9IR	R03/EXT9 External Interrupt Request Flag	0: Interrupt request flag is not pending, request flag bit clear
EXT8IR	R02/EXT8 External Interrupt Request Flag	
EXT7IR	R01/EXT7 External Interrupt Request Flag	1: Interrupt request flag is pending
EXT6IR	R00/EXT6 External Interrupt Request Flag	

EINTF**EXTERNAL INTERRUPT FLAG REGISTER****00CDH**

	7	6	5	4	3	2	1	0	
EINTFH	INT0IF	INT2IF	INT4IF	INT7IF	INT8IF	INT9IF	INT10IF	INT11IF	Reset value: 00H
	R/W	R/W	R/W	R/W	R/W	R/W	R/W	R/W	

EXT0IF	EXT0 External Interrupt Flag	0: Not generated 1: Generated
EXT2IF	EXT2 External Interrupt Flag	
EXT4IF	EXT4 External Interrupt Flag	
EXT7IF	EXT7 External Interrupt Flag	
EXT8IF	EXT8 External Interrupt Flag	
EXT9IF	EXT9 External Interrupt Flag	
EXT10IF	EXT10 External Interrupt Flag	
EXT11IF	EXT11 External Interrupt Flag	

12.2 Procedure

To generate external interrupt, following steps are required,

1. Prepare external interrupt sub-routine.
2. Set external interrupt pins to read mode
3. Enable the external interrupt and select the edge mode.
4. Make sure global interrupt is enabled(use 'EI' instruction).

After finish above steps, the external interrupt sub-routine is calling, when the edge is detected.

When the generated external interrupt is one of the external interrupts group, the EINTF register is used to recognize which external interrupt is generated.

13. CLOCK GENERATOR

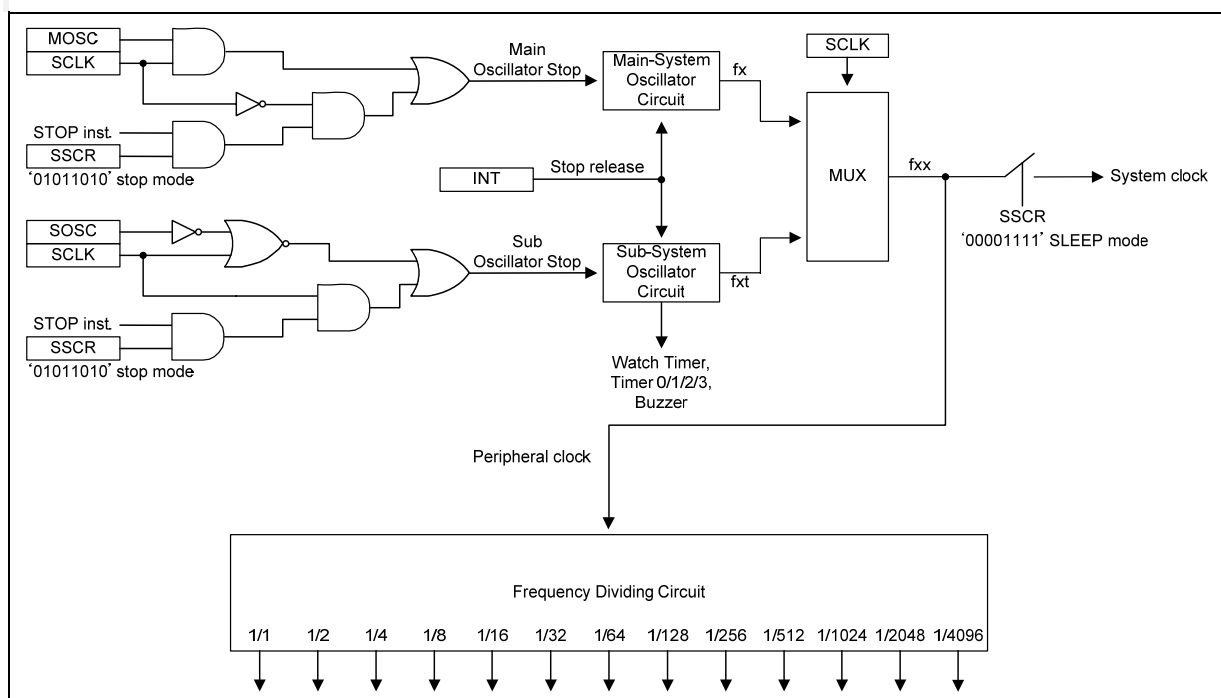

Figure 13-1 Block Diagram of Clock Generator

As shown in Figure 13-1, the clock generator produces the basic clock pulses for the CPU and the peripheral hardware.

It contains two oscillators which are main-system oscillator and a sub-oscillator. And for the system and the peripheral clocks, one oscillator is selected by the SCLK bit of the OSCSEL register.

There are few clock sources for main-oscillator which are listed below.

- Crystal / Ceramic Oscillator / (External Clock).
- 8, 4, 2, 1 MHz Internal RC Oscillator.
- External RC Oscillator.

Note that, one of the clock sources is used for main-oscillator based on the ROM option (See '8 . ROM OPTION' at page 61).

Only one clock source is available for sub-oscillator which is 'Crystal / Ceramic Oscillator / (External Clock) '.

To the peripheral block, the clock among the not-divided original clocks and divided by 2, 4..., up to 4096 can be provided. Peripheral clock is enabled or disabled by STOP instruction.

When the system is fall in stop mode, only selected oscillator(by SCLK bit) is stopped. Unselected oscillator is not affected by stop mode.

13.1 Registers

OSCSEL

OSCILLATOR SELECT REGISTER

00BCH

	7	6	5	4	3	2	1	0	
OSCSEL	-	-	-	-	-	MOSC	SOSC	SCLK	Reset value: 00H
	-	-	-	-	-	R/W	R/W	R/W	

-	bit7 – bit3	Not used for MC81F4x16
MOSC	Main Oscillator Control Bit	0: Main oscillator RUN 1: Main oscillator STOP
SOSC	Sub Oscillator Control Bit	0: Sub oscillator RUN 1: Sub oscillator STOP
SCLK	System Clock Selection Bit	0: Select main oscillator for system clock 1: Select sub oscillator for system clock

14. OSCILLATION CIRCUITS

There are few example circuits for main and sub oscillators.

Oscillation circuit is designed to be used either with a ceramic resonator or crystal oscillator. Since each crystal and ceramic resonator have their own characteristics, the user should consult the crystal manufacturer for appropriate values of external components.

14.1 Main Oscillation Circuits

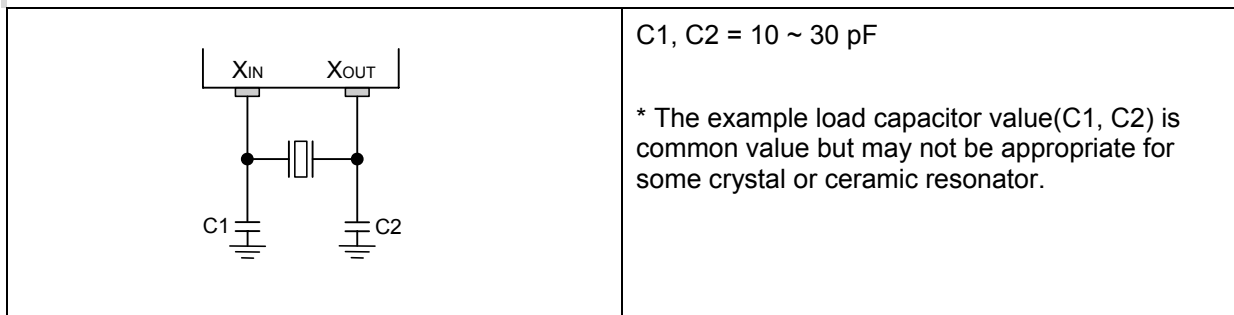

Figure 14-1 Crystal/Ceramic Oscillator

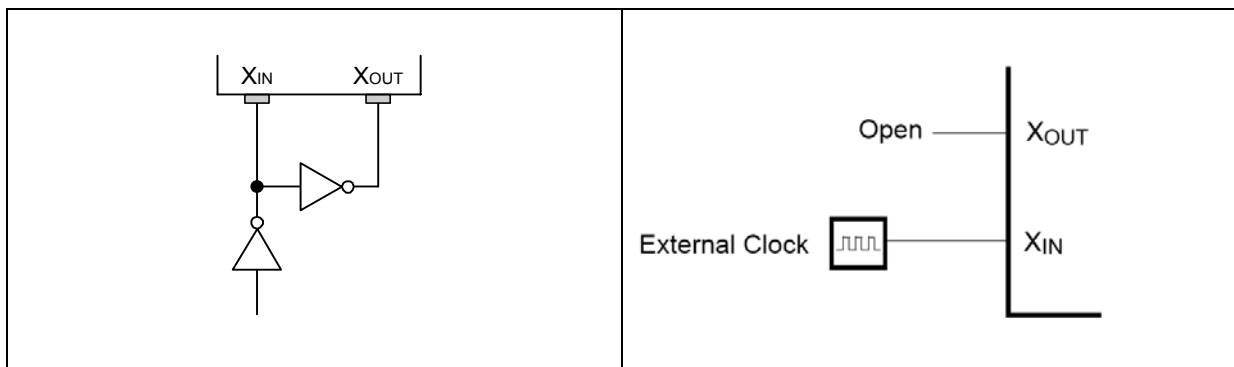

Figure 14-2 External Clock

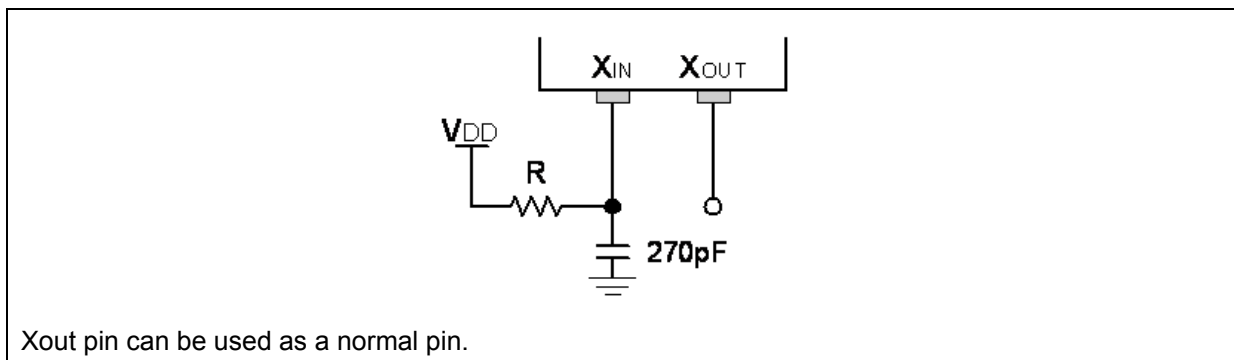

Figure 14-3 External RC Oscillator

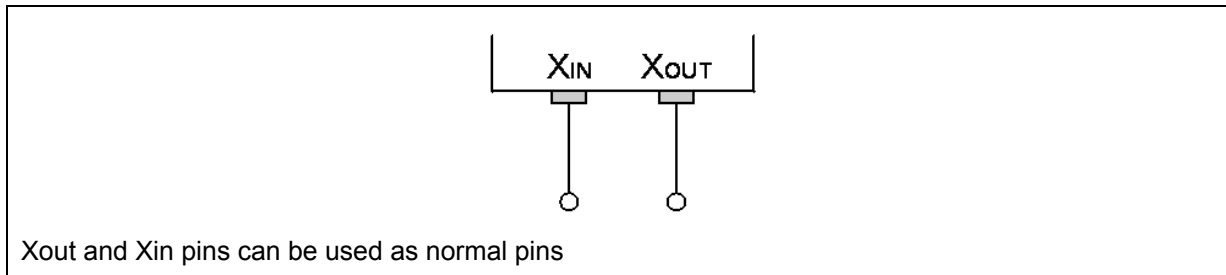

Figure 14-4 Internal RC Oscillator

14.2 Sub Oscillation Circuits

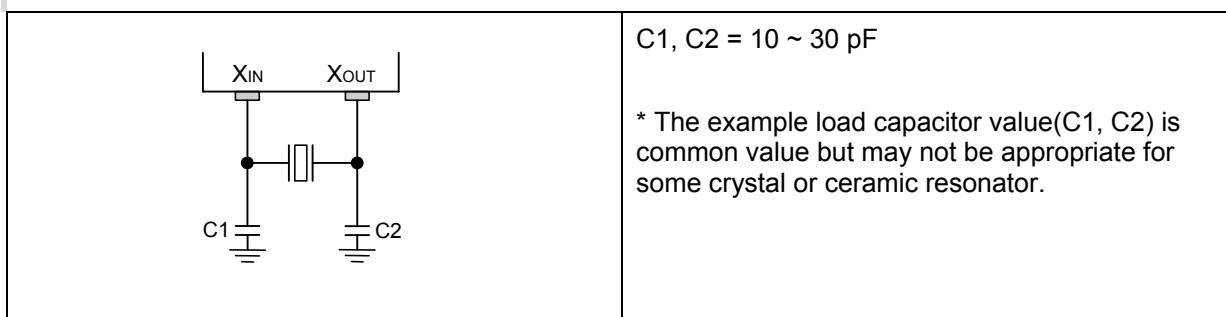

Figure 14-5 Crystal/Ceramic Oscillator

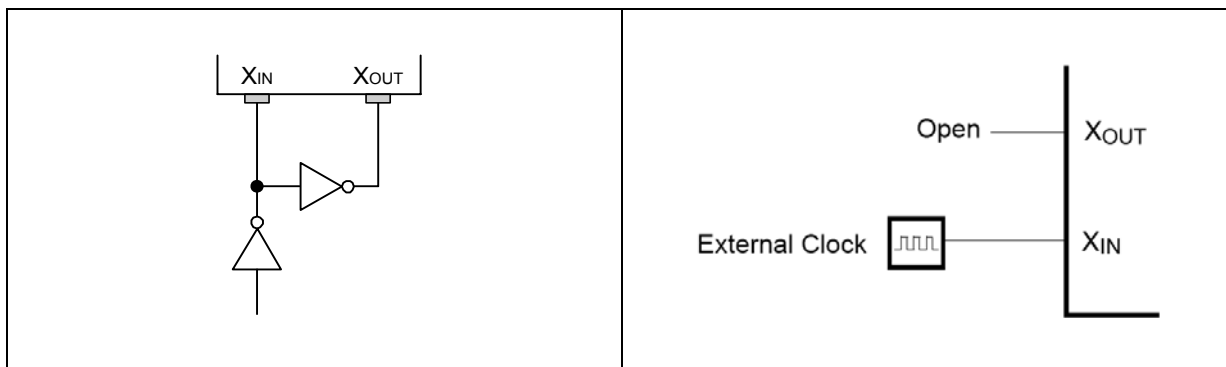

Figure 14-6 External Clock

14.3 PCB Layout

For reference, here is an example layout for oscillator circuit.

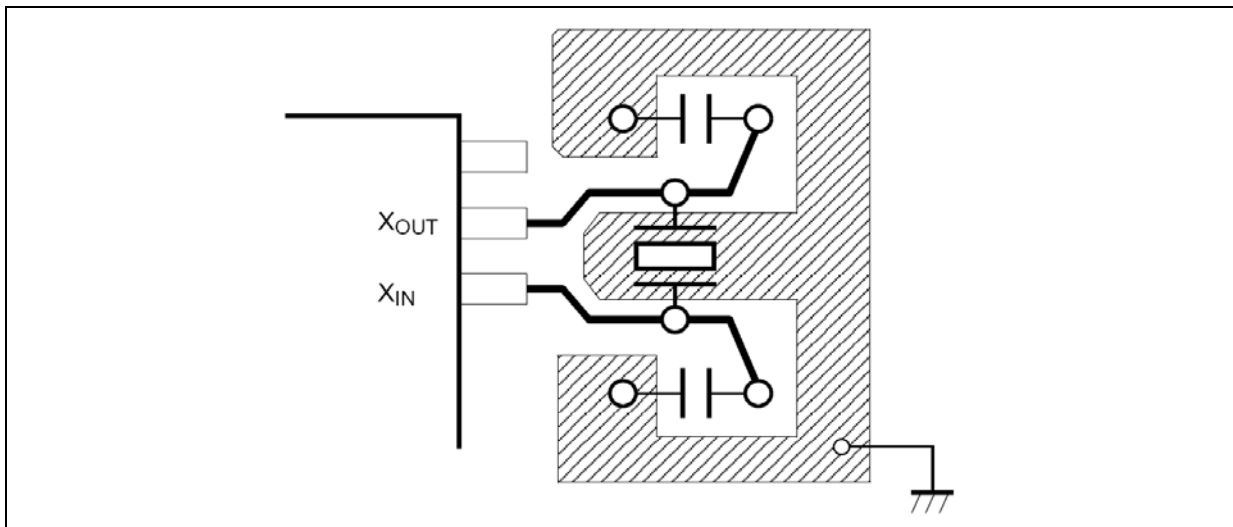

Figure 14-7 Layout of Oscillator PCB circuit

Note: Minimize the wiring length. Do not allow the wiring to intersect with other signal conductors. Do not allow the wiring to come near changing high current. Set the potential of the grounding position of the oscillator capacitor to that of V_{SS} . Do not ground it to any ground pattern where high current is present. Do not fetch signals from the oscillator.

15. BASIC INTERVAL TIMER

The MC81F4x16 has one 8-bit Basic Interval Timer that is free-run and can not be stopped except when peripheral clock is stopped.

The Basic Interval Timer generates the time base for watchdog timer counting. It also provides a Basic interval timer interrupt.

The 8-bit Basic interval timer register (BTCL) is increased every internal count pulse which is divided by prescaler. Since prescaler has divided ratio by 8 to 1024, the count rate is 1/8 to 1/1024 of the oscillator frequency.

As the count overflow from FFH to 00H, this overflow causes the interrupt to be generated. The Basic Interval Timer is controlled by the clock control register (CKCTLR).

When write "1" to bit BTCL of CKCTLR, BTCL register is cleared to "0" and restart to count-up. The bit BTCL becomes "0" after one machine cycle by hardware.

The bit WDTON decides Watchdog Timer or the normal 7-bit timer.

Source clock can be selected by lower 3 bits of CKCTLR.

15.1 Registers

CKCTLR

CLOCK CONTROL REGISTER

00F2H

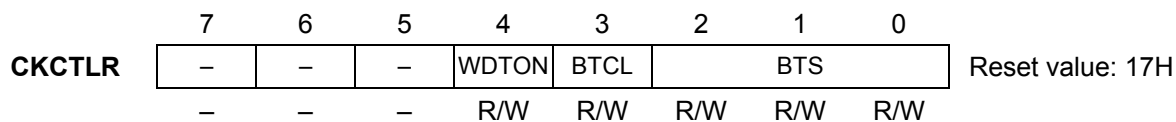

-	bit7 – bit5	Not used for MC81F4x16
WDTON	Watchdog Timer Enable Bit	0: Operate as 7-bit timer 1: Enable Watchdog timer
BTCL	Basic Timer Clear Bit	0: Normal operation (free-run) 1: Clear 8-bit counter (BITR) to “0”, This bit becomes 0 automatically after one machine cycle, and starts counting.
BTS	Basic Interval Timer Source Clock Selection Bits	000: fxin/8 001: fxin/16 010: fxin/32 011: fxin/64 100: fxin/128 101: fxin/256 110: fxin/512 111: fxin/1024

CKCTLR[2:0]	Source clock	Interrupt(overflow) period (ms) @ fxin = 8MHz
000	fxin/8	0.256
001	fxin/16	0.512
010	fxin/32	1.024
011	fxin/64	2.048
100	fxin/128	4.096
101	fxin/256	8.192
110	fxin/512	16.384
111	fxin/1024	32.768

Figure 15-1 Basic Interval Timer Interrupt Period

BTCR

BASIC TIMER COUNTER REGISTER

00F1H

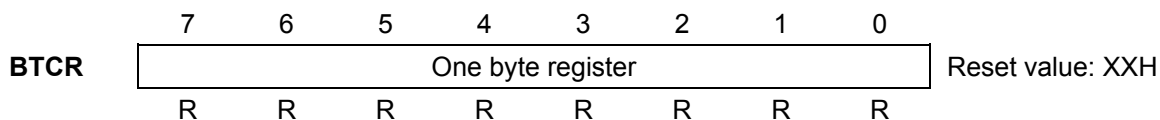

A 8 bit count register for the basic interval timer.

16. WATCH DOG TIMER

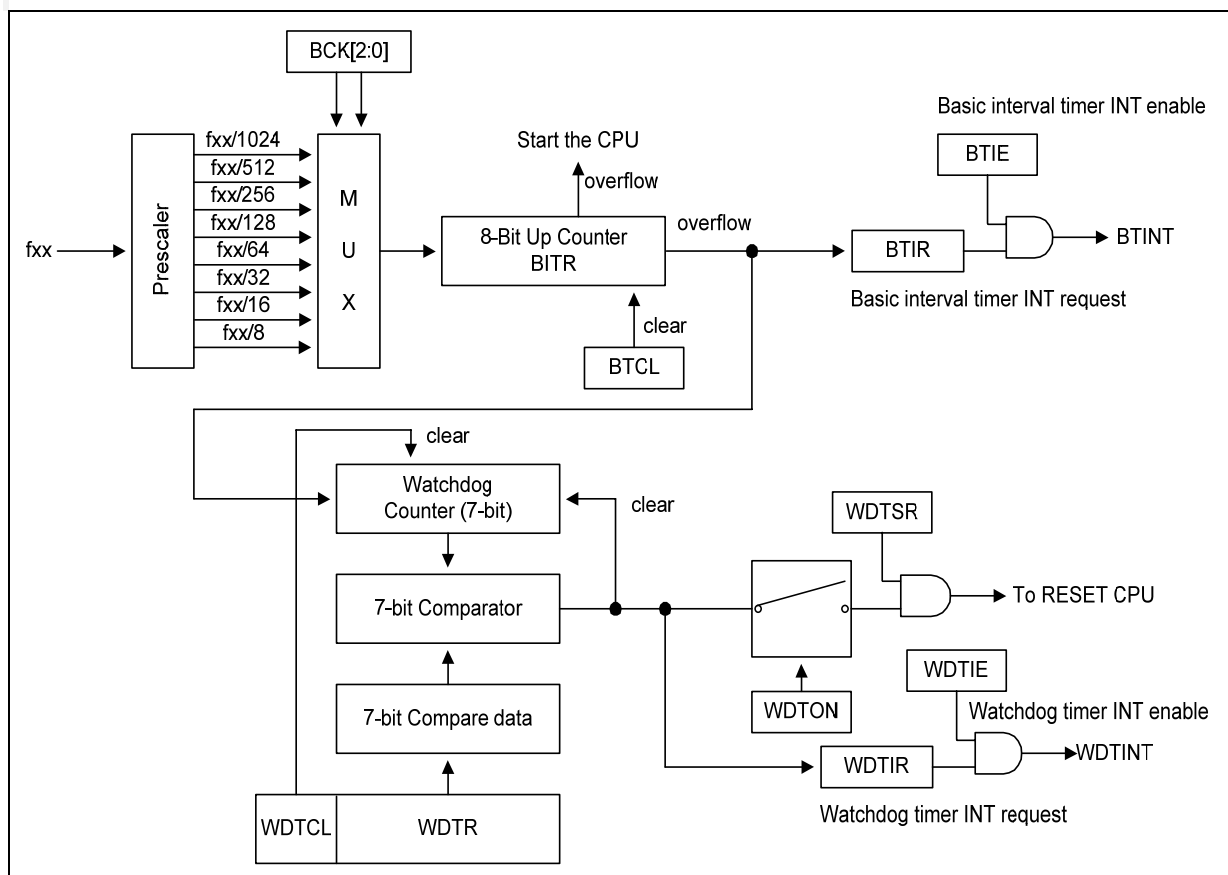

Figure 16-1 Block diagram of Basic Interval Timer/Watchdog Timer

The watchdog timer rapidly detects the CPU malfunction such as endless looping caused by noise or the like, and resumes the CPU to the normal state. The watchdog timer signal for detecting malfunction can be selected either a reset CPU or a interrupt request.

When the watchdog timer is not being used for malfunction detection, it can be used as a timer to generate an interrupt at fixed intervals.

The watchdog timer uses the Basic Interval Timer as a clock source.

The watchdog timer consists of 7-bit binary counter and the watchdog timer data register. When the value of 7-bit binary counter is equal to the lower 7 bits of WDR, the interrupt request flag is generated. This can be used as Watchdog timer interrupt or reset the CPU in accordance with the bit WDTON.

Watchdog reset feature is disabled when the watchdog timer status register(WDTSR) value is '0A5h'. Note that, WDTSR's reset value is '00h'. And reset value of WDTON is '1'. So watchdog timer reset is enabled at reset time.

16.1 Registers

WDTR

WATCHDOG TIMER REGISTER

00F4H

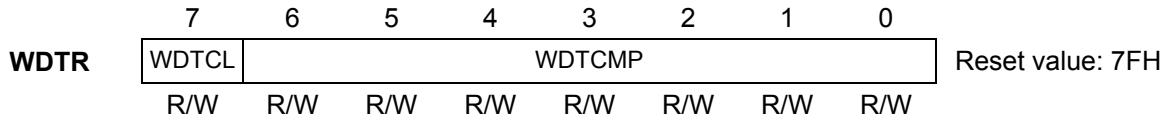

WDTCL	Watchdog Timer Clear Bit	0: Free-run count 1: When the WDTCL is set to "1", binary counter is cleared to "0". And the WDTCL becomes "0" automatically after one machine cycle. Counter count up again.
WDTCMP	bit6 – bit0	7-bit compare data

WDTSR

WATCHDOG TIMER STATUS REGISTER

00F6H

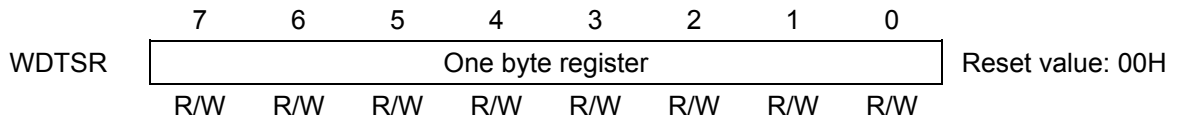

Watchdog Timer Function Disable Code (for System Reset)	10100101: Disable watchdog timer function Others: Enable watchdog timer function
---	---

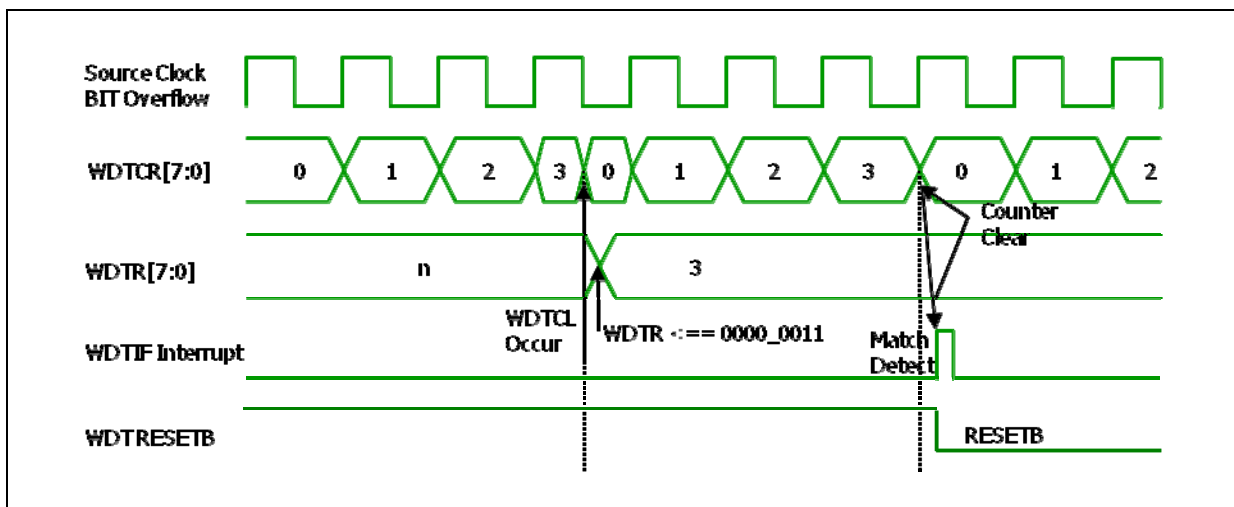

Figure 16-2 Watchdog Timer Timing

17. WATCH TIMER

Watch timer functions include real-time and watch-time measurement and interval timing for the system clock.

Watch timer has the following functional components:

- Real time and watch time measurement
- Using a main or sub clock source (main clock divided by 2^7 (fx/128) or sub clock(fxt))
- Timing tests in high-speed mode
- Watch timer interrupt generation
- Watch timer status and control register (WTSCR)

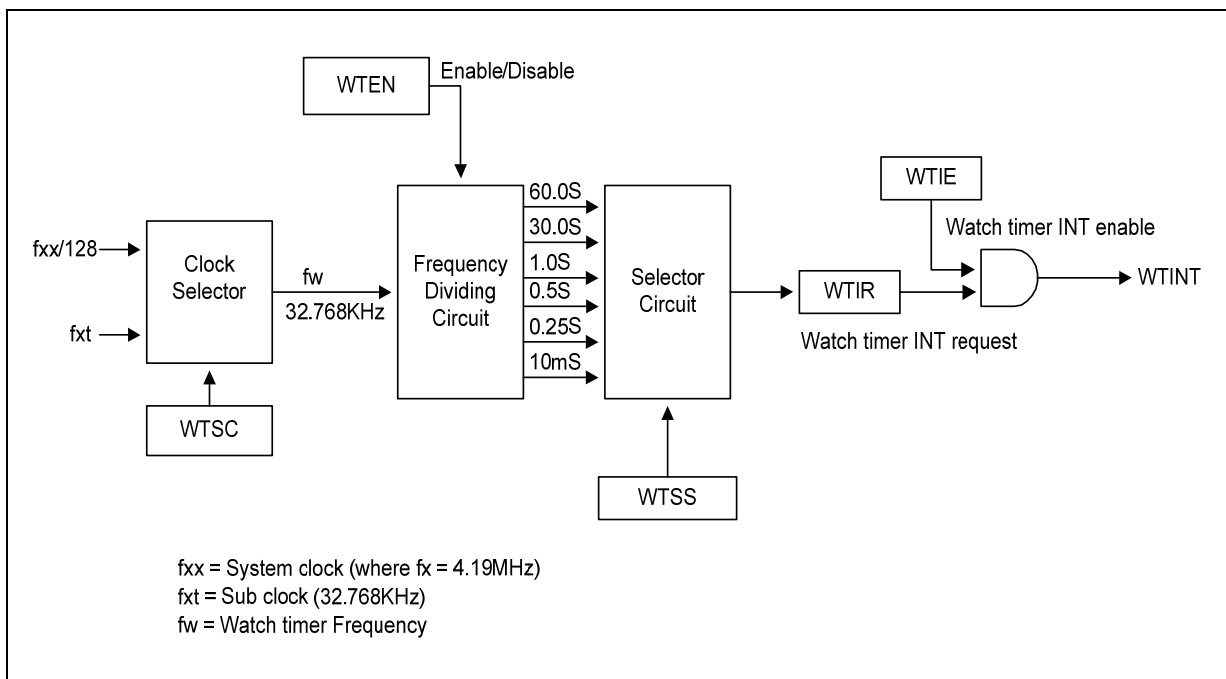

Figure 17-1 Watch Timer Block Diagram

17.1 Registers

WTSCR

WATCH TIMER STATUS AND CONTROL REGISTER

00F0H

	7	6	5	4	3	2	1	0	
WTSCR	–	WTEN	WTSS		–	–	–	WTCS	Reset value: 00H
	–	R/W	R/W	R/W	R/W	–	–	R/W	

A reset clears WTSCR register to '00H'. This disables the watch timer. So, if you want to use the watch timer, you must write appropriate value to WTSCR register.

When the watch timer interrupt sub-routine is serviced, the watch timer interrupt request flag bit, WTIR is automatically cleared.

–	bit7	Not used for MC81F4x16
WTEN	Watch Timer Enable Bit	0: Disable watch timer; Clear frequency Dividing circuits 1: Enable watch timer
WTSS	Watch Timer Speed Selection Bits	000: Set watch timer interrupt to 60.0s 001: Set watch timer interrupt to 30.0s 010: Not available 011: Not available 100: Set watch timer interrupt to 1.0s 101: Set watch timer interrupt to 0.5s 110: Set watch timer interrupt to 0.25s 111: 1/100s stop watch for real timer
–	bit2 – bit1	Not used for MC81F4x16
WTCS	Watch Timer Clock Selection Bit	0: Select main clock divided by 2^7 (fx/128) 1: Select sub clock (fxt)

Note: Main system clock frequency (fx) is assumed to be 4.19 MHz.

18. Timer 0/1

The 8-bit timer 0/1 are an 8-bit general-purpose timer. Timer 0/1 have three operating modes, you can select one of them using the appropriate T0SCR/T1SCR setting:

- Interval timer mode (Toggle output at T0O/T1O pin)
- Capture input mode with a rising or falling edge trigger at EXT1/EXT3 pin
- PWM mode (PWM0O/PWM1O)

18.1 Registers

T0DR

TIMER 0 DATA REGISTER

00B1H

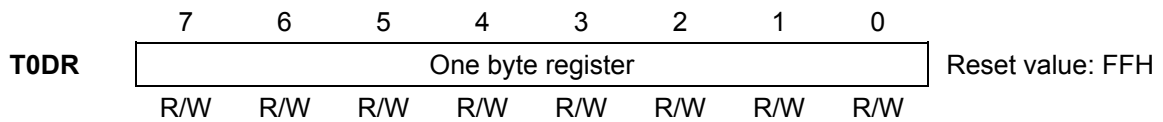

A 8-bit compare value register for the timer 0 match interrupt.

T0CR

TIMER 0 COUNTER REGISTER

00B2H

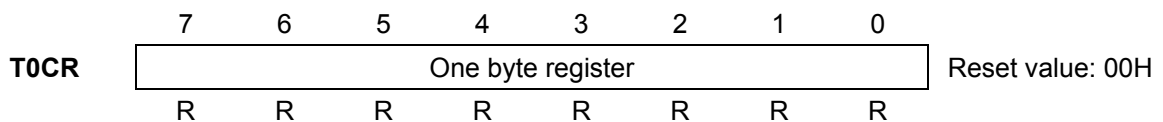

A 8-bit count register for the timer 0

T0SCR**TIMER 0 STATUS AND CONTROL REGISTER****00B0H**

To enable the timer 0 match interrupt, you must set “1” to T0MIE(IENH.7).

When the timer 0 match interrupt sub-routine is serviced, the timer 0 match interrupt request flag bit, T0MIR(IRQH.7), is automatically cleared.

To enable the timer 0 overflow interrupt, you must set “1” to T0OVIE(IENH.6).

When the timer 0 overflow interrupt sub-routine is serviced, the timer 0 overflow interrupt request flag bit, T0OVIR(IRQH.6), is automatically cleared.

	7	6	5	4	3	2	1	0	
T0SCR	T0MOD	T0MS		T0CC	T0CS				Reset value: 00H
	R/W	R/W	R/W	R/W	R/W	R/W	R/W	R/W	

T0MOD	Timer 0 mode Selection Bit	0: Two 8-bit timers mode (Timer 0/1) 1: One 16-bit timer mode (Timer 0)
T0MS	Timer 0 Mode Selection Bit	00: Interval mode (T0O) 01: PWM mode (OVF and match interrupt can occur) 1X: Capture mode (OVF can occur)
T0CC	Timer 0 Counter Clear Bit	0: No effect 1: Clear the Timer 0 counter (When write, automatically cleared “0” after being cleared counter)
T0CS	Timer 0 Clock Selection Bits	0000: Counter stop 0001: Not available 0010: Not available 0011: Not available 0100: Not available 0101: External clock (EC0) rising edge 0110: External clock (EC0) falling edge 0111: fxt (sub clock) 1000: fxx/2 1001: fxx/4 1010: fxx/8 1011: fxx/16 1100: fxx/32 1101: fxx/128 1110: fxx/512 1111: fxx/2048

Note :

You must set the T0CC(T0SCR.4) bit after set T0DR register. The timer 0 counter value is compared with timer 0 buffer register instead of T0DR. And T0DR value is copied to timer 0 buffer register when 1)T0CC is set 2)T0OVIR is set 3) T0MIR is set.

T1DR

TIMER 1 DATA REGISTER

00B4H

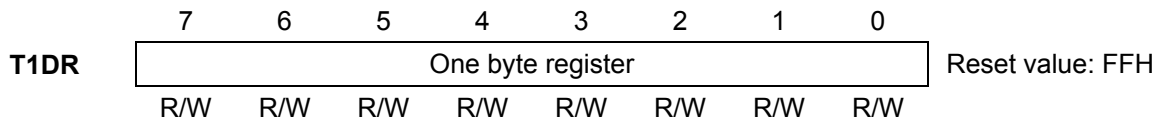

A 8-bit compare value register for the timer 1 match interrupt.

T1CR

TIMER 0 COUNTER REGISTER

00B5H

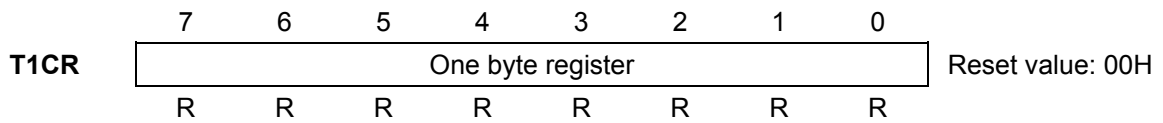

A 8-bit count register for the timer 1

T1SCR

TIMER 1 STATUS AND CONTROL REGISTER

00B3H

To enable the timer 1 match interrupt, you must set “1” to T1MIE.

When the timer 1 match interrupt sub-routine is serviced, the timer 1 match interrupt request flag bit, T1MIR(IRQH.5), is automatically cleared..

To enable the timer 1 overflow interrupt, you must set “1” to T1OVIE.

When the timer 1 overflow interrupt sub-routine is serviced, the timer 1 overflow interrupt request flag bit, T1OVIR(IRQH.4), is automatically cleared.

	7	6	5	4	3	2	1	0	
T1SCR	–	T1MS	T1CC	T1CS					Reset value: 00H
	R/W	R/W	R/W	R/W	R/W	R/W	R/W	R/W	

–	bit7	Not used for MC81F4x16
T1MS	Timer 1 Mode Selection Bit	00: Interval mode (T1O) 01: PWM mode (OVF and match interrupt can occur) 1X: Capture mode (OVF can occur)
T1CC	Timer 1 Counter Clear Bit	0: No effect 1: Clear the Timer 1 counter (When write, automatically cleared “0” after being cleared counter)
T1CS	Timer 1 Clock Selection Bits	0000: Counter stop 0001: Not available 0010: Not available 0011: Not available 0100: Not available 0101: External clock (EC1) rising edge 0110: External clock (EC1) falling edge 0111: fxt (sub clock) 1000: fxx/1 1001: fxx/2 1010: fxx/4 1011: fxx/8 1100: fxx/16 1101: fxx/64 1110: fxx/256 1111: fxx/1024

Note: You must set the T1CC(T1SCR.4) bit after set T1DR register. The timer 1 counter value is compared with timer 1 buffer register instead of T1DR. And T1DR value is copied to timer 1 buffer.

18.2 Timer 0 8-Bit Mode

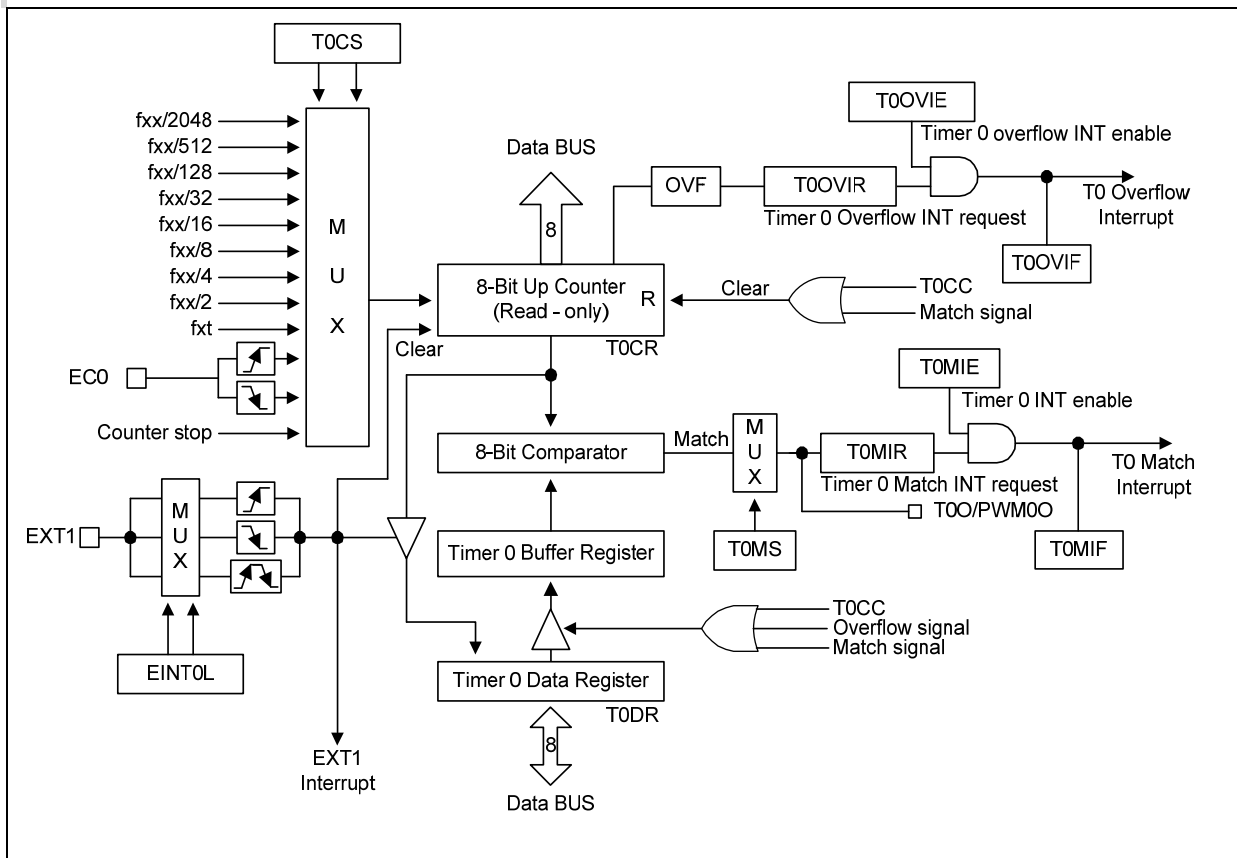

Figure 18-1 8-bit Timer 0 Block Diagram

Timer 0 has the following functional components:

- Clock frequency divider (fxx divided by 2048, 512, 128, 32, 16, 8, 4, 2, fxt) with multiplexer
- External clock input pin, EC0 (R02)
- I/O pins for capture input, EXT1 (R03) or PWM or match output PWM00/T00 (R03)
- 8-bit counter (T0CR), 8-bit comparator, and 8-bit reference data register (T0DR)
- Timer 0 status and control register (T0SCR)
- Timer 0 overflow interrupt and match interrupt generation

Function Description

Interval Timer Mode

A match signal is generated and T0O pins are toggled when the T0CR register value equals the T0DR register value. The match signal generates a timer match interrupt and clears the T0CR register.

Pulse Width Modulation Mode

Pulse width modulation (PWM) mode lets you program the width (duration) of the pulse that is output at the PWM0O pin. As in interval timer mode, a match signal is generated when the counter value is identical to the value written to the T0DR register. In PWM mode, however, the match signal does not clear the counter. Instead, it runs continuously, overflowing at FFH, and then continues incrementing from 00H.

Although you can use the match signal to generate a timer 0 overflow interrupt, interrupts are not typically used in PWM-type applications. Instead, the pulse at the PWM0O pin is held to Low level as long as the reference data value is less than or equal to (\leq) the counter value and then the pulse is held to High level for as long as the data value is greater than ($>$) the counter value. One pulse width is equal to $t_{CLK} * 256$.

So, the period and duty times are,

$$\begin{aligned} \text{Duty} &= t_{CLK} * (T0DR + 1) \\ \text{Period} &= t_{CLK} * 256 \end{aligned}$$

In order to generate the PWM0O signal, 3 steps are required,

Steps	Example C code
Make sure the PWM0O port is set by PWM output mode	T0CONM = 0x03;
Set the T0DR value properly	T0DR = 25;
Set the T0SCR register properly	T0SCR = 0x38;

Capture Mode

In capture mode, you have to set EXT1 interrupt. When the EXT1 interrupt is occurred, the T0CR register value is loaded into the T0DR register and the T0CR register is cleared.

And the timer 0 overflow interrupt is generated whenever the T0CR value is overflowed.

So, If you count how many overflow is occurred and read the T0DR value in EXT1 interrupt routine, it is possible to measure the time between two EXT1 interrupts. Or it is possible to measure the time from the T0 initial time to the EXT1 interrupt occurred time.

$$\text{The time} = (256 * t_{CLK}) * \text{overflow_count} + (t_{CLK} * T0DR)$$

Note

' t_{CLK} ' is the period time of the timer-counter's clock source

You must set the T0DR value before set the T0SCR register. Because T0DR value is fetched when the count is started(the T0CC bit is set) or match/overflow event is occurred.

18.3 Timer 1 8-Bit Mode

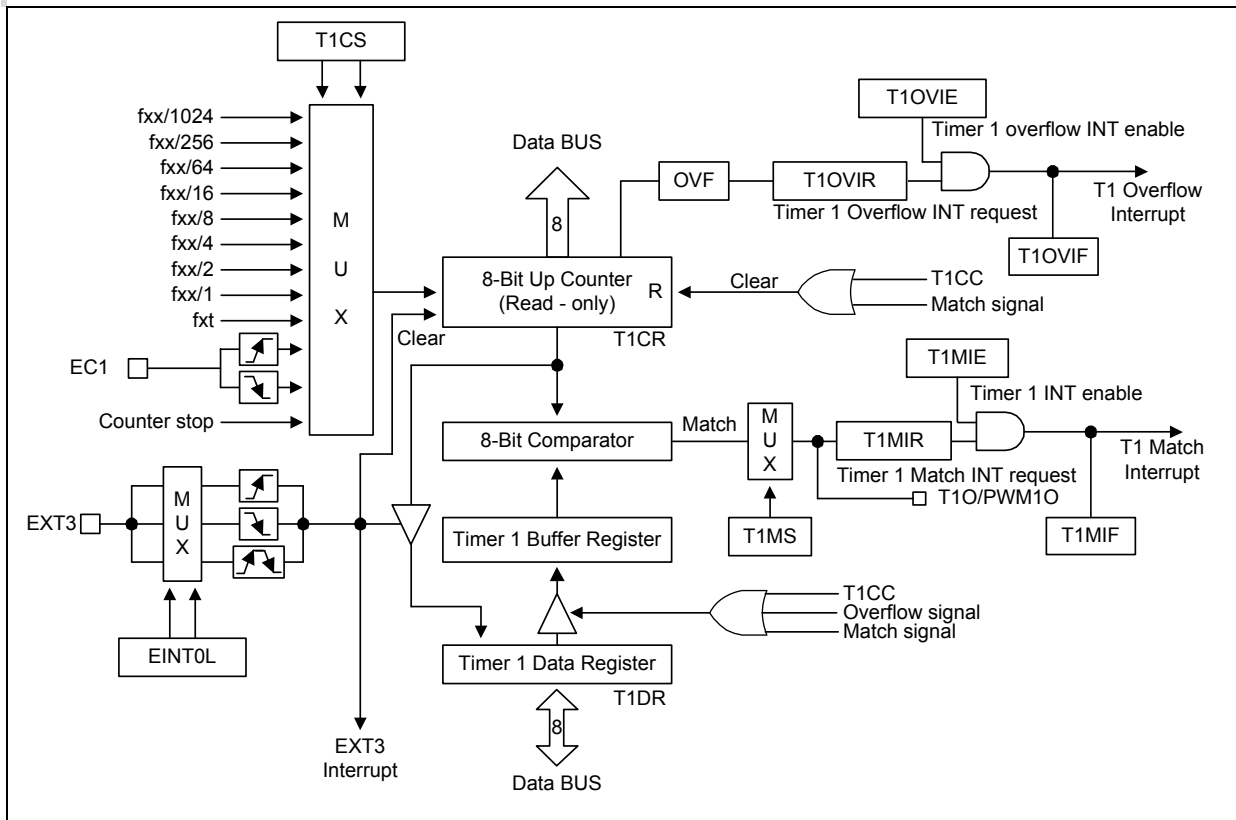

Figure 18-2 8-bit Timer 1 Block Diagram

Timer 1 has the following functional components:

- Clock frequency divider (fxx divided by 1024, 256, 64, 16, 8, 4, 2, 1, fxt) with multiplexer
- External clock input pin, EC1 (R04)
- I/O pins for capture input, EXT3 (R05) or PWM or match output PWM10/T1O (R05)
- 8-bit counter (T1CR), 8-bit comparator, and 8-bit reference data register (T1DR)
- Timer 1 status and control register (T1SCR)
- Timer 1 overflow interrupt and match interrupt generation

Function Description

Interval Timer Mode

A match signal is generated and T1O pins are toggled when the T1CR register value equals the T1DR register value. The match signal generates a timer match interrupt and clears the T1CR register.

Pulse Width Modulation Mode

Pulse width modulation (PWM) mode lets you program the width (duration) of the pulse that is output at the PWM1O pin. As in interval timer mode, a match signal is generated when the counter value is identical to the value written to the T1DR register. In PWM mode, however, the match signal does not clear the counter. Instead, it runs continuously, overflowing at FFH, and then continues incrementing from 00H.

Although you can use the match signal to generate a timer 1 overflow interrupt, interrupts are not typically used in PWM-type applications. Instead, the pulse at the PWM1O pin is held to Low level as long as the reference data value is less than or equal to (\leq) the counter value and then the pulse is held to High level for as long as the data value is greater than ($>$) the counter value. One pulse width is equal to $t_{CLK} * 256$.

So, the period and duty times are,

$$\begin{aligned} \text{Duty} &= t_{CLK} * (T1DR + 1) \\ \text{Period} &= t_{CLK} * 256 \end{aligned}$$

In order to generate the PWM1O signal, 3 steps are required,

Steps	Example C code
Make sure the PWM1O port is set by PWM output mode	T1CONM = 0xC0;
Set the T1DR value properly	T1DR = 25;
Set the T1SCR register properly	T1SCR = 0x38;

Capture Mode

In capture mode, you have to set EXT3 interrupt. When the EXT3 interrupt is occurred, the T1CR register value is loaded into the T1DR register and the T1CR register is cleared.

And the timer 1 overflow interrupt is generated whenever the T1CR value is overflowed.

So, If you count how many overflow is occurred and read the T1DR value in EXT3 interrupt routine, it is possible to measure the time between two EXT3 interrupts. Or it is possible to measure the time from the T1 initial time to the EXT3 interrupt occurred time.

$$\text{The time} = (256 * t_{CLK}) * \text{overflow_count} + (t_{CLK} * T1DR)$$

Note

' t_{CLK} ' is the period time of the timer-counter's clock source
You must set the T1DR value before set the T1SCR register. Because T1DR value is fetched when the count is started(the T1CC bit is set) or match/overflow event is occurred.

18.4 Timer 0 16-BIT Mode

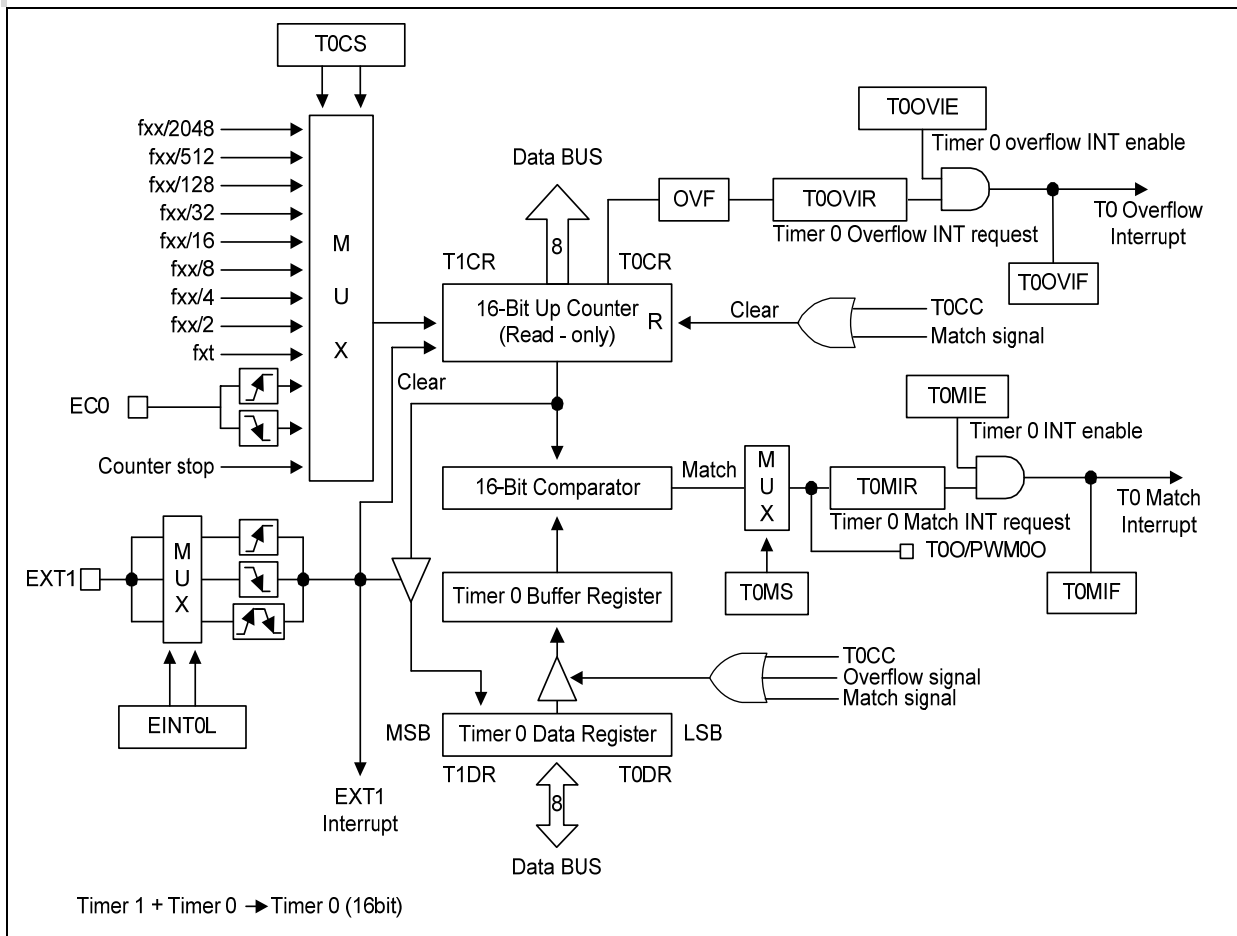

Figure 18-3 16-bit Timer 0 Block Diagram

The 16-bit timer 0 is a 16-bit general-purpose timer. Timer 0 has three operating modes, you can select one of them using the appropriate T0SCR setting:

- Interval timer mode (Toggle output at T0O pin)
- Capture input mode with a rising or falling edge trigger at EXT1 pin
- PWM mode (PWM00)

The 16-bit timer 0 has the following functional components:

- Clock frequency divider (fxx divided by 2048, 512, 128, 32, 16, 8, 4, 2, fxt) with multiplexer
- External clock input pin, EC0 (R02)
- I/O pins for capture input, EXT1 (R03) or PWM or match output PWM00/T0O (R03)
- 16-bit counter (T0CR+T1CR), 16-bit comparator, and 16-bit reference data register (T0DR+T1DR)
- Timer 0 status and control register (T0SCR)
- Timer 0 overflow interrupt and match interrupt generation

Function Description

Interval Timer Mode

A match signal is generated and T0O pins are toggled when the T0CR+T1CR register value equals the T0DR+T1DR. The match signal generates a timer match interrupt and clears the T0CR and the T1CR register.

If, for example, you write the value 24H to T0DR, 10H to T1DR and 9FH to T0SCR, the counter will increment until it reaches 1024H. At this point, the Timer 0 math interrupt request is generated, the counter value is reset, and counting resumes.

Pulse Width Modulation Mode

Pulse width modulation (PWM) mode lets you program the width (duration) of the pulse that is output at the PWM0O pin. As in interval timer mode, a match signal is generated when the counter value is identical to the value written to the T0DR+T1DR. In PWM mode, however, the match signal does not clear the counter. Instead, it runs continuously, overflowing at FFH, and then continues incrementing from 0000H.

Although you can use the match signal to generate a timer 0 overflow interrupt, interrupts are not typically used in PWM-type applications. Instead, the pulse at the PWM0O pin is held to Low level as long as the reference data value is less than or equal to (\leq) the counter value and then the pulse is held to High level for as long as the data value is greater than ($>$) the counter value. One pulse width is equal to $t_{CLK} * 65536$.

So, the period and duty times are,

$$\text{Duty} = t_{CLK} * ((T1DR \ll 8) + T0DR)$$

$$\text{Period} = t_{CLK} * 65536$$

In order to generate the PWM0O signal, 3 steps are required,

Steps	Example C code
Make sure the PWM0O port is set by PWM output mode	T0CONM = 0x03;
Set the T0DR, T1DR value properly	T1DR = 1; T0DR = 25;
Set the T0SCR register properly	T0SCR = 0xB8;

Capture Mode

In capture mode, you have to set EXT1 interrupt. When the EXT1 interrupt is occurred, the T0CR and T1CR register value is loaded into the T0DR and T1DR register and the T0CR and T1CR register is cleared.

And the timer 0 overflow interrupt is generated whenever the T0CR+T1CR value is overflowed.

So, If you count how many overflow is occurred and read the T0DR+T1DR value in EXT1 interrupt routine, it is possible to measure the time between two EXT1 interrupts. Or it is possible to measure the time from the T0 initial time to the EXT1 interrupt occurred time.

The time = (65536* tCLK) * overflow_count + (tCLK * (T0CR+(T1DR<<8)))

Note

'tCLK' is the period time of the timer-counter's clock source

You must set the T0DR and T1DR values before set the T0SCR register. Because T0DR and T1DR values are fetched when the count is started(the T0CC bit is set) or match/overflow event is occurred.

19. Timer 2/3

The 8-bit timer 2/3 are an 8-bit general-purpose timer. Timer 2/3 have two operating modes, you can select one of them using the appropriate T2SCR/T3SCR setting:

- Interval timer mode (Toggle output at T2O pin)
- Capture input mode with a rising or falling edge trigger at EXT5/6 pin

19.1 Registers

T2DR

TIMER 2 DATA REGISTER

00B7H

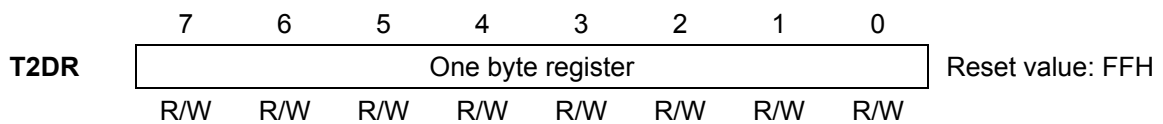

A 8-bit compare value register for the timer 2 match interrupt.

T2CR

TIMER 2 COUNTER REGISTER

00B8H

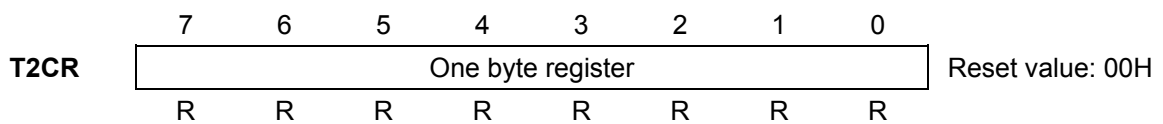

A 8-bit count register for the timer 2

T2SCR

TIMER 2 STATUS AND CONTROL REGISTER (T2SCR)

00B6H

To enable the timer 2 match interrupt, you must set “1” to T2MIE.

When the timer 2 match interrupt sub-routine is serviced, the timer 1 match interrupt request flag bit, T2MIR(IRQH.3), is automatically cleared.

To enable the timer 2 overflow interrupt, you must set “1” to T2OVIE.

When the timer 2 overflow interrupt sub-routine is serviced, the timer 2 overflow interrupt request flag bit, T2OVIR(IRQH.2), is automatically cleared.

	7	6	5	4	3	2	1	0	
T2SCR	T2MOD	–	T2MS	T2CC	T2CS				Reset value: 00H
	R/W	–	R/W	R/W	R/W	R/W	R/W	R/W	

T2MOD	Timer 2 mode Selection Bit	0: Two 8-bit timers mode (Timer 2/3) 1: One 16-bit timer mode (Timer 2)
–	bit6	Not used for MC81F4x16
T2MS	Timer 2 Mode Selection Bit	0: Interval mode (T2O) 1: Capture mode (OVF can occur)
T2CC	Timer 2 Counter Clear Bit	0: No effect 1: Clear the Timer 2 counter (When write, automatically cleared “0” after being cleared counter)
T2CS	Timer 2 Clock Selection Bits	0000: Counter stop 0001: Not available 0010: Not available 0011: Not available 0100: Not available 0101: External clock (EC2) rising edge 0110: External clock (EC2) falling edge 0111: fxt (sub clock) 1000: fxx/1 1001: fxx/2 1010: fxx/4 1011: fxx/8 1100: fxx/16 1101: fxx/64 1110: fxx/256 1111: fxx/1024

Note: You must set the T2CC(T2SCR.4) bit after set T2DR register. The timer 2 counter value is compared with timer 2 buffer register instead of T2DR. And T2DR value is copied to timer 2 buffer.

T3DR

TIMER 3 DATA REGISTER

00BAH

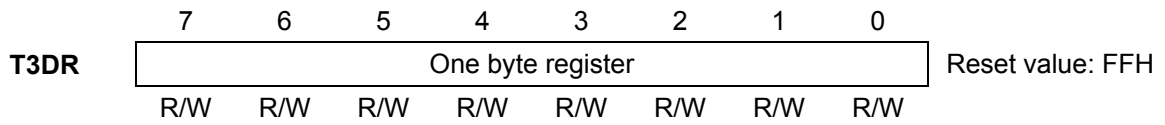

A 8-bit compare value register for the timer 3 match interrupt.

T3CR

TIMER 3 COUNTER REGISTER

00BBH

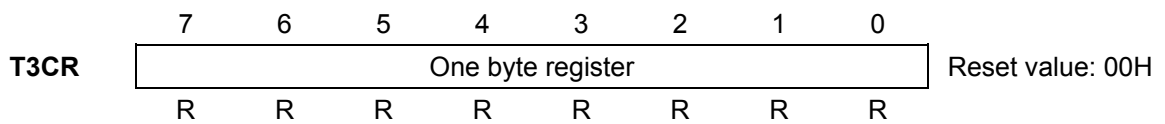

A 8-bit count register for the timer 3

T3SCR

TIMER 3 STATUS AND CONTROL REGISTER (T3SCR)

00D3H

To enable the timer 3 match interrupt, you must set “1” to T3MIE.

When the timer 3 match interrupt sub-routine is serviced, the timer 1 match interrupt request flag bit, T3MIR(IRQH.1), is automatically cleared.

To enable the timer 3 overflow interrupt, you must set “1” to T3OVIE.

When the timer 3 overflow interrupt sub-routine is serviced, the timer 3 overflow interrupt request flag bit, T3OVIR(IRQH.0), is automatically cleared.

	7	6	5	4	3	2	1	0	
T3SCR	–	–	T3MS	T3CC	T3CS				Reset value:
	–	–	R/W	R/W	R/W	R/W	R/W	R/W	--00_0000b

–	bit7 – bit6	Not used for MC81F4x16
T3MS	Timer 3 Mode Selection Bit	0: Interval mode 1: Capture mode (OVF can occur)
T3CC	Timer 3 Counter Clear Bit	0: No effect 1: Clear the Timer 3 counter (When write, automatically cleared “0” after being cleared counter)
T3CS	Timer 3 Clock Selection Bits	0000: Counter stop 0001: Not available 0010: Not available 0011: Not available 0100: Not available 0101: External clock (EC3) rising edge 0110: External clock (EC3) falling edge 0111: fxt (sub clock) 1000: fxx/2 1001: fxx/4 1010: fxx/8 1011: fxx/16 1100: fxx/32 1101: fxx/128 1110: fxx/512 1111: fxx/2048

Note: You must set the T3CC(T3SCR.4) bit after set T3DR register. The timer 3 counter value is compared with timer 3 buffer register instead of T3DR. And T3DR value is copied to timer 3 buffer.

19.2 Timer 2 8-Bit Mode

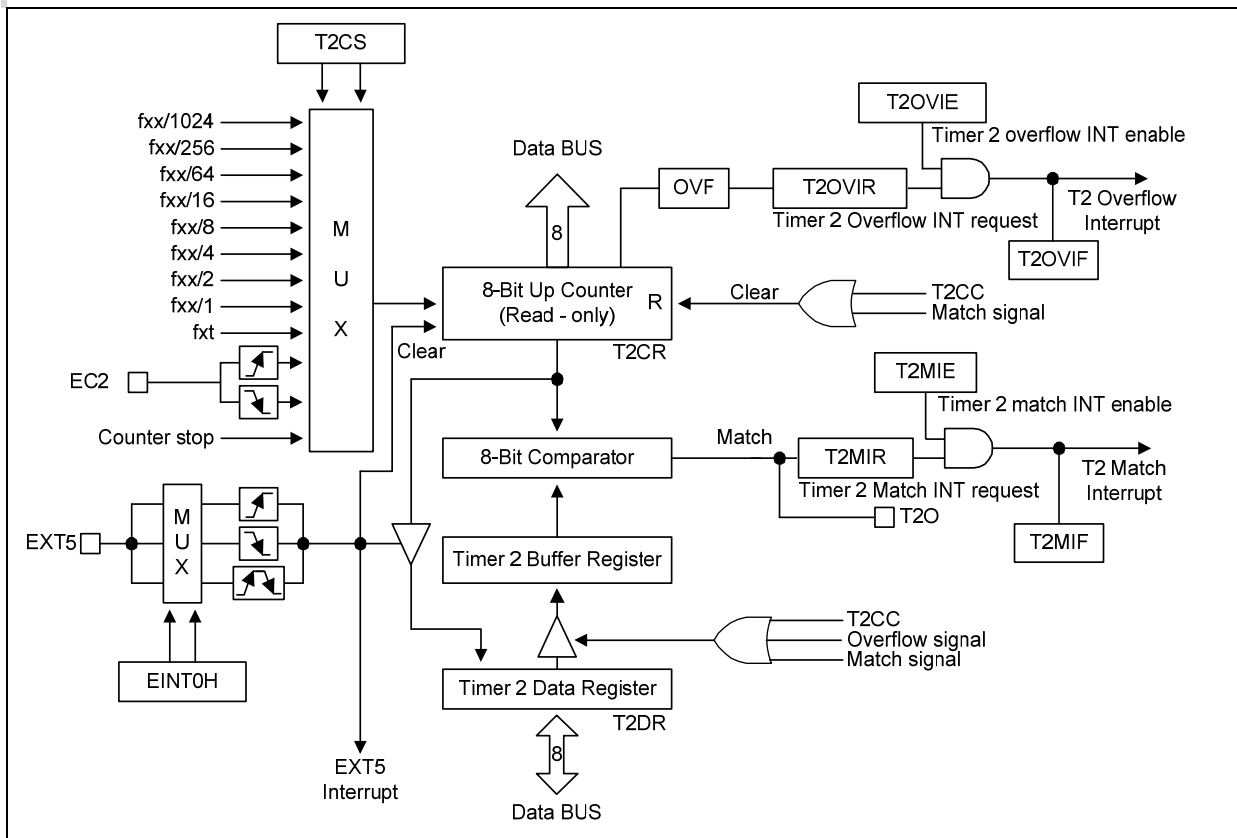

Figure 19-1 8-bit Timer 2 Block Diagram

Timer 2 has the following functional components:

- Clock frequency divider (fxx divided by 1024, 256, 64, 16, 8, 4, 2, 1, fxt) with multiplexer
- External clock input pin, EC2 (R06)
- I/O pins for capture input, EXT5 (R07) or match output T2O (R07)
- 8-bit counter (T2CR), 8-bit comparator, and 8-bit reference data register (T2DR)
- Timer 2 status and control register (T2SCR)
- Timer 2 overflow interrupt and match interrupt generation

Function Description

Interval Timer Mode

A match signal is generated and T2O pins are toggled when the T2CR register value equals the T2DR register value. The match signal generates a timer match interrupt and clears the T2CR register.

Capture Mode

In capture mode, you have to set EXT5 interrupt. When the EXT5 interrupt is occurred, the T2CR register value is loaded into the T2DR register and the T2CR register is cleared.

And the timer 2 overflow interrupt is generated whenever the T2CR value is overflowed.

So, If you count how many overflow is occurred and read the T2DR value in EXT5 interrupt routine, it is possible to measure the time between two EXT5 interrupts. Or it is possible to measure the time from the T2 initial time to the EXT5 interrupt occurred time.

The time = (256 * tCLK) * overflow_count + (tCLK * T2DR)

Note

'tCLK' is the period time of the timer-counter's clock source

You must set the T2DR value before set the T2SCR register. Because T2DR value is fetched when the count is started(the T2CC bit is set) or match/overflow event is occurred.

19.3 Timer 3 8-Bit Mode

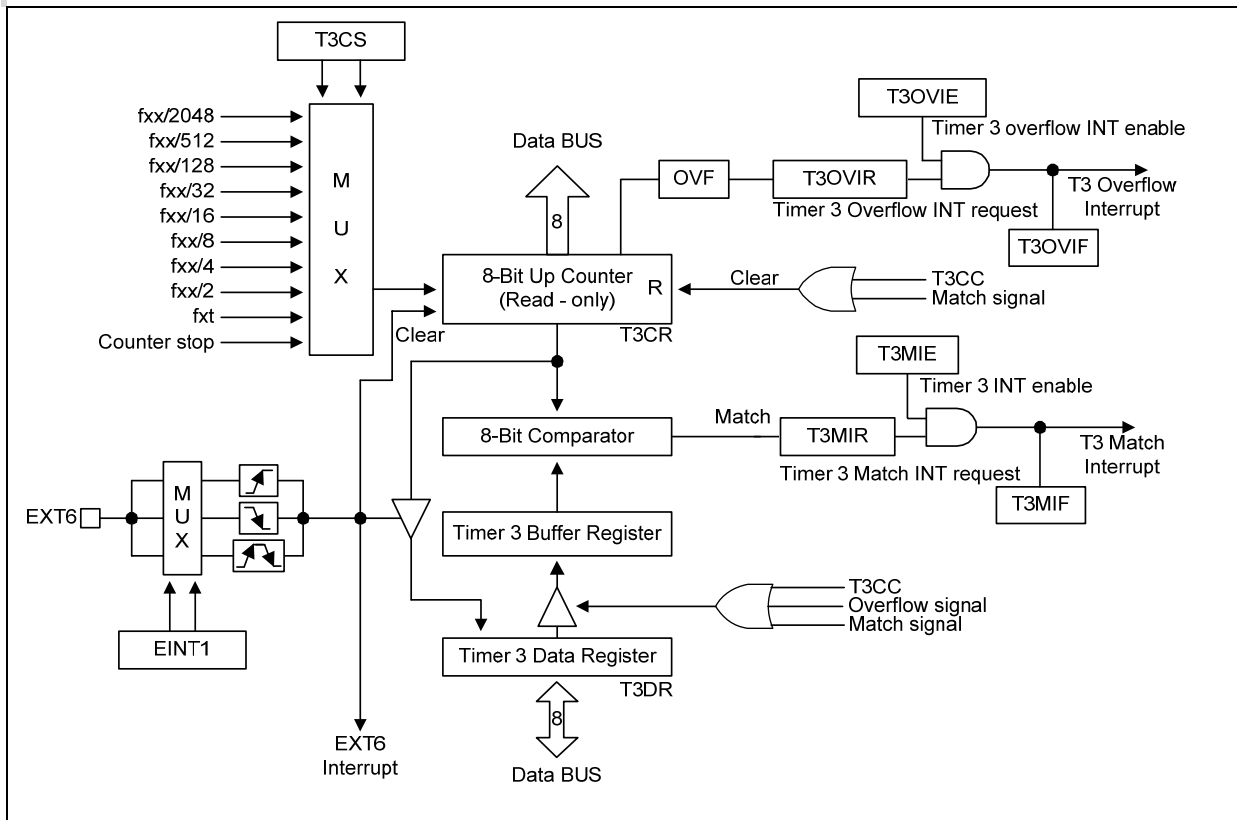

Figure 19-2 8-bit Timer 3 Block Diagram

Timer 3 has the following functional components:

- Clock frequency divider (fxx divided by 2048, 512, 128, 32, 16, 8, 4, 2, fxt) with multiplexer
- I/O pins for capture input, EXT6 (R10)
- 8-bit counter (T3CR), 8-bit comparator, and 8-bit reference data register (T3DR)
- Timer 3 status and control register (T3SCR)
- Timer 3 overflow interrupt and match interrupt generation

Function Description

Interval Timer Mode

A match signal is generated and T3O pins are toggled when the T3CR register value equals the T3DR register value. The match signal generates a timer match interrupt and clears the T3CR register.

Capture Mode

In capture mode, you have to set EXT6 interrupt. When the EXT6 interrupt is occurred, the T3CR register value is loaded into the T3DR register and the T3CR register is cleared.

And the timer 3 overflow interrupt is generated whenever the T3CR value is overflowed.

So, If you count how many overflow is occurred and read the T3DR value in EXT6 interrupt routine, it is possible to measure the time between two EXT6 interrupts. Or it is possible to measure the time from the T3 initial time to the EXT6 interrupt occurred time.

The time = (256 * tCLK) * overflow_count + (tCLK * T3DR)

Note

'tCLK' is the period time of the timer-counter's clock source

You must set the T3DR value before set the T3SCR register. Because T3DR value is fetched when the count is started(the T3CC bit is set) or match/overflow event is occurred.

19.4 Timer 2 16-Bit Mode

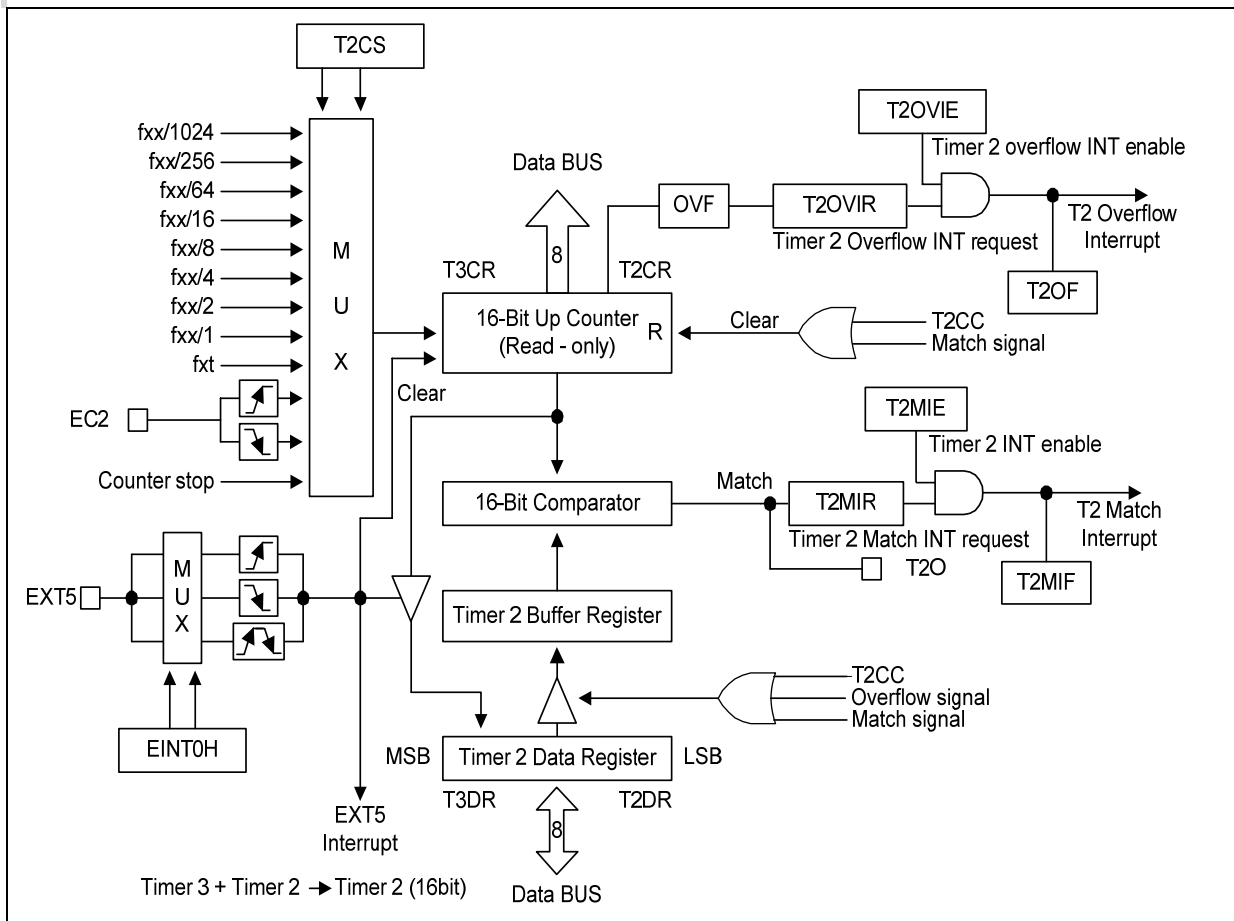

Figure 19-3 16-bit Timer 2 Block Diagram

The 16-bit timer 2 is a 16-bit general-purpose timer. Timer 2 has two operating modes, you can select one of them using the appropriate T2SCR setting:

- Interval timer mode (Toggle output at T2O pin)
- Capture input mode with a rising or falling edge trigger at EXT5 pin

The 16-bit timer 2 has the following functional components:

- Clock frequency divider (fxx divided by 1024, 256, 64, 16, 8, 4, 2, 1, fxt) with multiplexer
- External clock input pin, EC2 (R06)
- I/O pins for capture input, EXT5 (R07) or match output T2O (R07)
- 16-bit counter (T2CR+T3CR), 16-bit comparator, and 16-bit reference data register (T2DR+T3DR)
- Timer 2 status and control register (T2SCR)
- Timer 2 overflow interrupt and match interrupt generation

Function Description

Interval Timer Mode

A match signal is generated and T2O pins are toggled when the T2CR+T3CR register value equals the T2DR+T3DR. The match signal generates a timer match interrupt and clears the T2CR and the T3CR register.

If, for example, you write the value 24H to T2DR, 10H to T3DR and 9FH to T2SCR, the counter will increment until it reaches 1024H. At this point, the Timer 0 math interrupt request is generated, the counter value is reset, and counting resumes.

Capture Mode

In capture mode, you have to set EXT5 interrupt. When the EXT5 interrupt is occurred, the T2CR and T2CR register value is loaded into the T2DR and T3DR register and the T2CR and T3CR register is cleared.

And the timer 2 overflow interrupt is generated whenever the T2CR+T3CR value is overflowed.

So, If you count how many overflow is occurred and read the T2DR+T3DR value in EXT5 interrupt routine, it is possible to measure the time between two EXT5 interrupts. Or it is possible to measure the time from the T2 initial time to the EXT5 interrupt occurred time.

The time = $(65536 * t_{CLK}) * \text{overflow_count} + (t_{CLK} * (T2CR + (T3DR \ll 8)))$

Note

't_{CLK}' is the period time of the timer-counter's clock source

You must set the T2DR and T3DR values before set the T2SCR register. Because T2DR and T3DR values are fetched when the count is started(the T2CC bit is set) or match/overflow event is occurred.

20. High Speed PWM

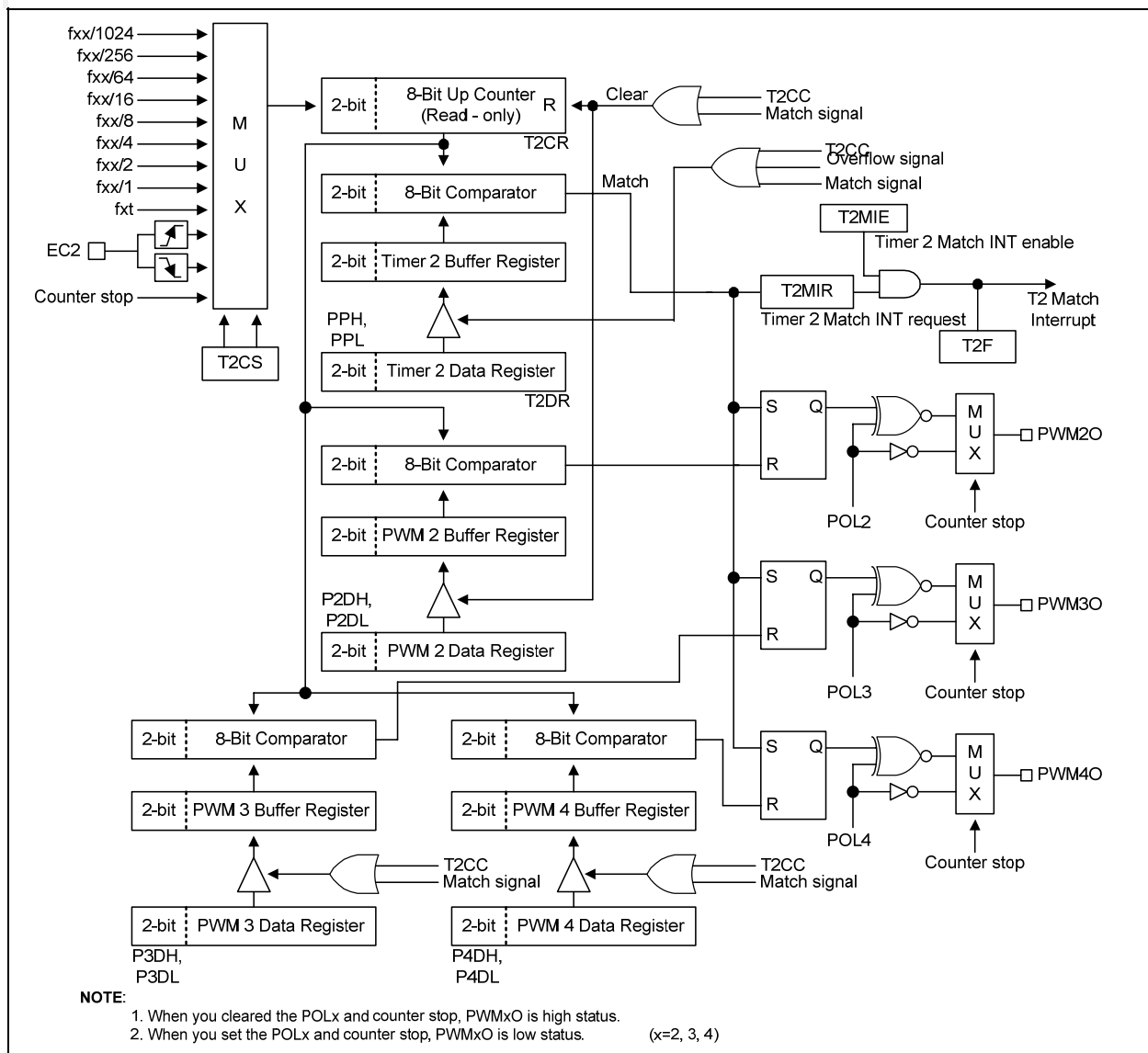

Figure 20-1 High Speed PWM Block Diagram

The MC81F4x16 has three high speed PWM (Pulse Width Modulation) function which shared with Timer2.

In PWM mode, the R11/PWM2O, R12/PWM3O, R13/PWM4O pins operate as a 10-bit resolution PWM output port. For this mode, the R11 of R1CONL, the R12 and the R13 of R1CONM should be set to alternative function mode.

The period of the PWM output is determined by the T2DR (T2 data Register) and PWMPDR[1:0] (PWM Period Duty Register) and the duty of the PWM output is determined by the PWM2DR, PWM3DR, PWM4DR (PWM Data Register) and PWMPDR[7:2] (PWM Period Duty Register).

User can use PWM data by writing the lower 8-bit period value to the T2DR and the higher 2-bit period value to the PWMPDR[1:0]. And the duty value can be used with the PWM2DR, PWM3DR, PWM4DR and the PWMPDR[7:2] in the same way.

The bit POL2, POL3 and POL4 of PWMSCR decides the polarity of duty cycle. The duty value can be changed when the PWM outputs. However the changed duty value is output after the current period is over. And it can be maintained the duty value at present output when changed only period value shown as Example of PWM2. As it were, the absolute duty time is not changed in varying frequency.

Note: When user need to change mode from the Timer2 mode to the PWM mode, the Timer2 should be stopped firstly, and then set period and duty register value. If user writes register values and changes mode to PWM mode while Timer2 is in operation, the PWM data would be different from expected data in the beginning.

PWM Period = [PWMPDR[1:0]T2DR+1] X Source Clock
 PWM2 Duty = [PWMPDR[3:2]PWM2DR+1] X Source Clock
 PWM3 Duty = [PWMPDR[5:4]PWM3DR+1] X Source Clock
 PWM4 Duty = [PWMPDR[7:6]PWM4DR+1] X Source Clock

If it needed more higher frequency of PWM, it should be reduced resolution.

Note: If the duty value and the period value are same, the PWM output is determined by the bit POL (1: High, 0: Low). And if the duty value is set to "00H", the PWM output is determined by the bit POL(1: Low, 0: High). The period value must be same or more than the duty value, and 00H cannot be used as the period value.

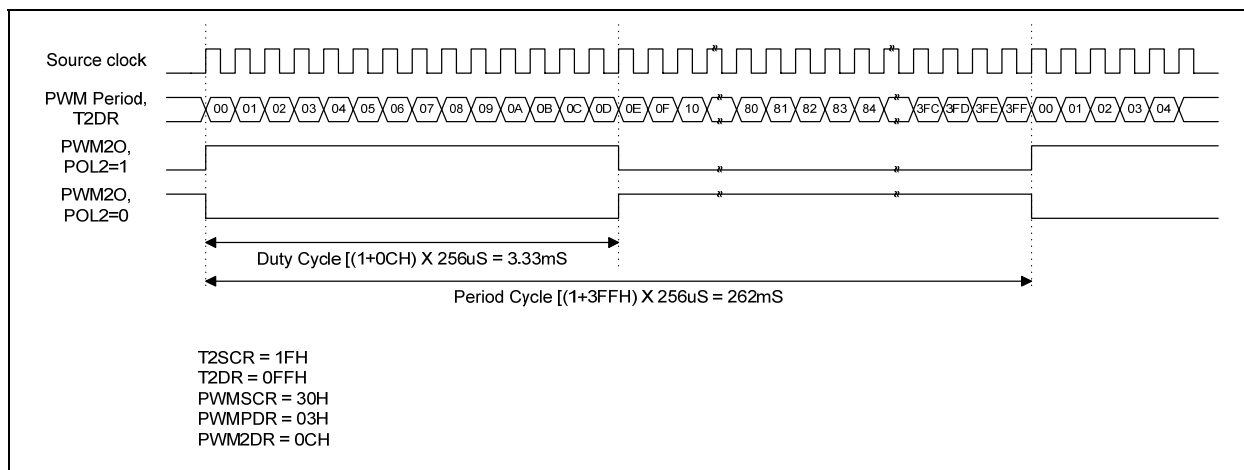

Figure 20-2 Example of PWM2 at 8MHz

20.1 Registers

PWMSCR

PWM STATUS AND CONTROL REGISTER (PWMSCR)

00CEH

	7	6	5	4	3	2	1	0	
PWMSCR	POL4	POL3	POL2	PWMS	–	–	–	–	Reset value: 0-H
	R/W	R/W	R/W	R/W	–	–	–	–	

POL4	PWM 4 Polarity Selection Bit	0: PWM 4 duty active low 1: PWM 4 duty active high
POL3	PWM 3 Polarity Selection Bit	0: PWM 3 duty active low 1: PWM 3 duty active high
POL2	PWM 2 Polarity Selection Bit	0: PWM 2 duty active low 1: PWM 2 duty active high
PWMS	PWM Selection Bit	0: Timer 2 mode (interval or capture) 1: PWM mode (PWM2O, PWM3O, PWM4O)
–	Bit3 – bit0	Not used for MC81F4x16

PWMPDR

PWM PERIOD DUTY REGISTER

00CFH

	7	6	5	4	3	2	1	0	
PWMPDR	P4DH	P4DL	P3DH	P3DL	P2DH	P2DL	PPH	PPL	Reset value: FFH
	R/W	R/W	R/W	R/W	R/W	R/W	R/W	R/W	

P4DH	PWM 4 Duty High Bit	PWM4 duty value (9,8th bits)
P4DL	PWM 4 Duty Low Bit	
P3DH	PWM 3 Duty High Bit	PWM3 duty value (9,8th bits)
P3DL	PWM 3 Duty Low Bit	
P2DH	PWM 2 Duty High Bit	PWM2 duty value (9,8th bits)
P2DL	PWM 2 Duty Low Bit	
PPH	PWM Period High Bit	Period value (9/8th bits)
PPL	PWM Period Low Bit	

PWM2DR

PWM 2 DATA REGISTER

00D0H

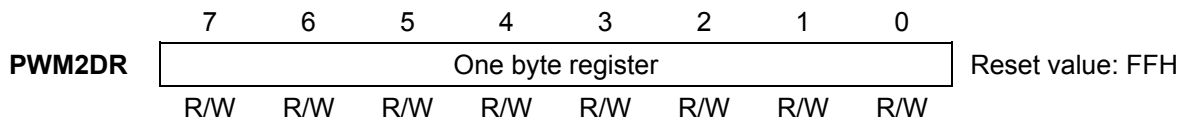

A 8-bit data register for lower bits of 10-bit PWM 2 duty value.

PWM3DR

PWM 3 DATA REGISTER

00D1H

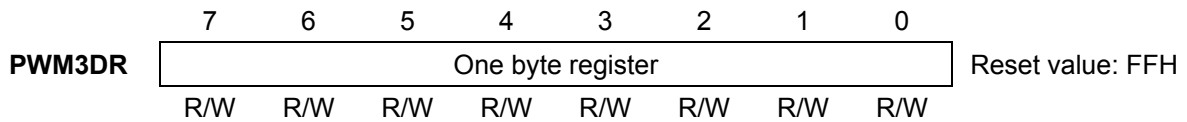

A 8-bit data register for lower bits of 10-bit PWM 3 duty value.

PWM4DR

PWM 4 DATA REGISTER

00D2H

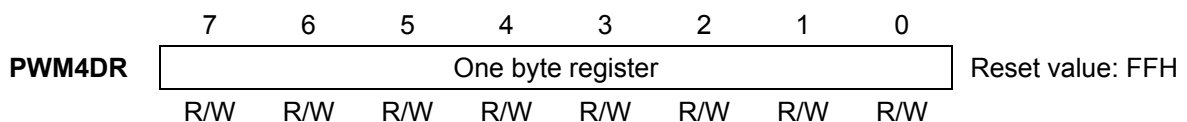

A 8-bit data register for lower bits of 10-bit PWM 4 duty value.

21. BUZZER

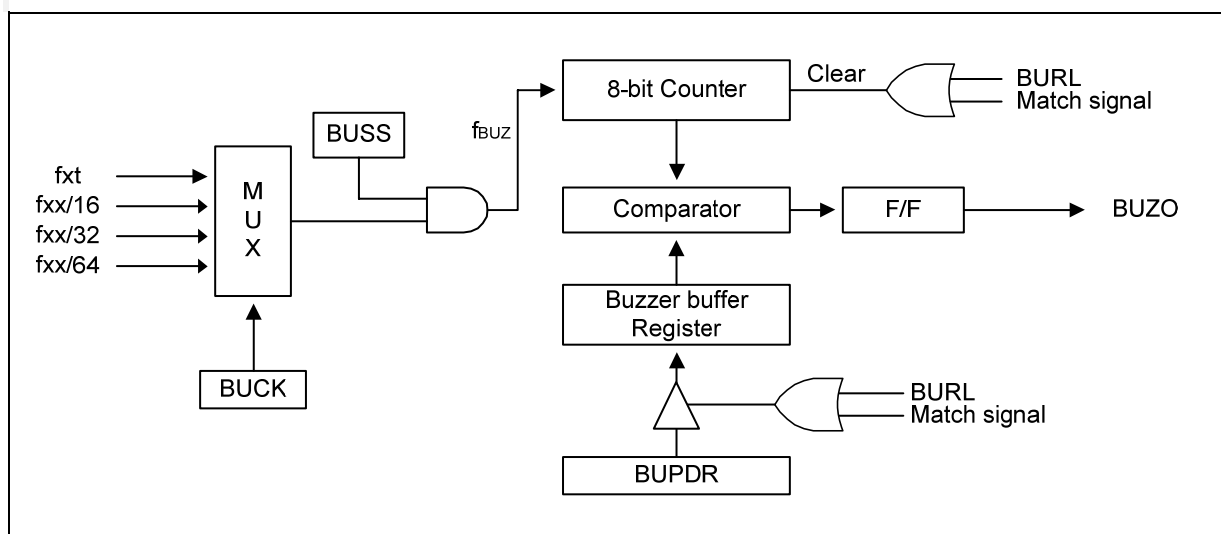

Figure 21-1 Buzzer Driver Block Diagram

The buzzer driver consists of 8-bit binary counter, the buzzer period data register BUPDR, and the buzzer driver register BUZR, the clock selector. It generates square-wave which is very wide range frequency (244 Hz ~ 250 KHz at $f_{xx} = 8\text{MHz}$) by user programmable counter.

Pin R12/BUZO is assigned for output port of Buzzer driver by setting the bits R12 of R1 Control Middle Register (R0CONM) to "101".

The 8-bit buzzer counter is cleared and start the counting by writing signal to the register BUZR. It is increased from 00H until it matches with BUPDR[7:0].

Also, it is cleared by counter overflow and count up to output the square wave pulse of duty 50%.

The bit 0 to 7 of BUPDR determines output frequency for buzzer driving. BUPDR is initialized to FFH after reset.

Frequency calculation is following as shown below.

21.1 Registers

BUZR

BUZZER DRIVER REGISTER

00E5H

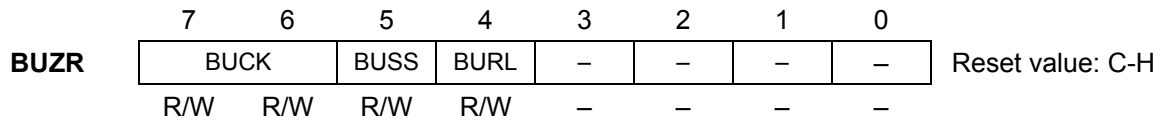

BUCK	Buzzer Clock Selection Bit	00: fxt (sub clock) 01: fxx/16 10: fxx/32 11: fxx/64
BUSS	Buzzer Start/Stop Bit	0: Disable Buzzer 1: Enable Buzzer
BURL	Buzzer Data Reload Bit	0: No effect 1: Reload buzzer data to buffer
-	bit3 – bit1	Not used for MC81F4x16

BUPDR

BUZZER PERIOD DATA REGISTER

00E6H

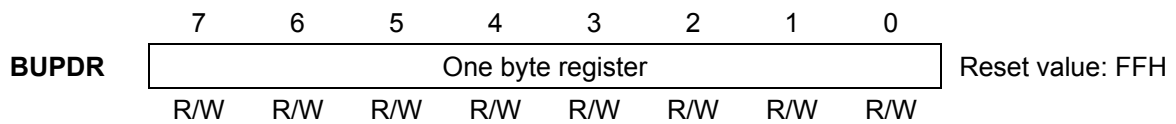

A 8-bit data register for the buzzer period value.

21.2 Frequency table

System Clock = 4MHz

BUCK :01 = div16

frequency unit = KHz

High nibble	Low nibble of BUPDR							
	0	1	2	3	4	5	6	7
0	125.000	62.500	41.667	31.250	25.000	20.833	17.857	15.625
1	7.353	6.944	6.579	6.250	5.952	5.682	5.435	5.208
2	3.788	3.676	3.571	3.472	3.378	3.289	3.205	3.125
3	2.551	2.500	2.451	2.404	2.358	2.315	2.273	2.232
4	1.923	1.894	1.866	1.838	1.812	1.786	1.761	1.736
5	1.543	1.524	1.506	1.488	1.471	1.453	1.437	1.420
6	1.289	1.276	1.263	1.250	1.238	1.225	1.214	1.202
7	1.106	1.096	1.087	1.078	1.068	1.059	1.050	1.042
8	0.969	0.962	0.954	0.947	0.940	0.933	0.926	0.919
9	0.862	0.856	0.850	0.845	0.839	0.833	0.828	0.822
A	0.776	0.772	0.767	0.762	0.758	0.753	0.749	0.744
B	0.706	0.702	0.698	0.694	0.691	0.687	0.683	0.679
C	0.648	0.644	0.641	0.638	0.635	0.631	0.628	0.625
D	0.598	0.595	0.592	0.590	0.587	0.584	0.581	0.579
E	0.556	0.553	0.551	0.548	0.546	0.543	0.541	0.539
F	0.519	0.517	0.514	0.512	0.510	0.508	0.506	0.504

High nibble	Low nibble of BUPDR							
	8	9	A	B	C	D	E	F
0	13.889	12.500	11.364	10.417	9.615	8.929	8.333	7.813
1	5.000	4.808	4.630	4.464	4.310	4.167	4.032	3.906
2	3.049	2.976	2.907	2.841	2.778	2.717	2.660	2.604
3	2.193	2.155	2.119	2.083	2.049	2.016	1.984	1.953
4	1.712	1.689	1.667	1.645	1.623	1.603	1.582	1.563
5	1.404	1.389	1.374	1.359	1.344	1.330	1.316	1.302
6	1.190	1.179	1.168	1.157	1.147	1.136	1.126	1.116
7	1.033	1.025	1.016	1.008	1.000	0.992	0.984	0.977
8	0.912	0.906	0.899	0.893	0.887	0.880	0.874	0.868
9	0.817	0.812	0.806	0.801	0.796	0.791	0.786	0.781
A	0.740	0.735	0.731	0.727	0.723	0.718	0.714	0.710
B	0.676	0.672	0.668	0.665	0.661	0.658	0.654	0.651
C	0.622	0.619	0.616	0.613	0.610	0.607	0.604	0.601
D	0.576	0.573	0.571	0.568	0.566	0.563	0.561	0.558
E	0.536	0.534	0.532	0.530	0.527	0.525	0.523	0.521
F	0.502	0.500	0.498	0.496	0.494	0.492	0.490	0.488

Ex) BUPDR = 0xFC -> Freq = 0.494KHz

22. 12-BIT ADC

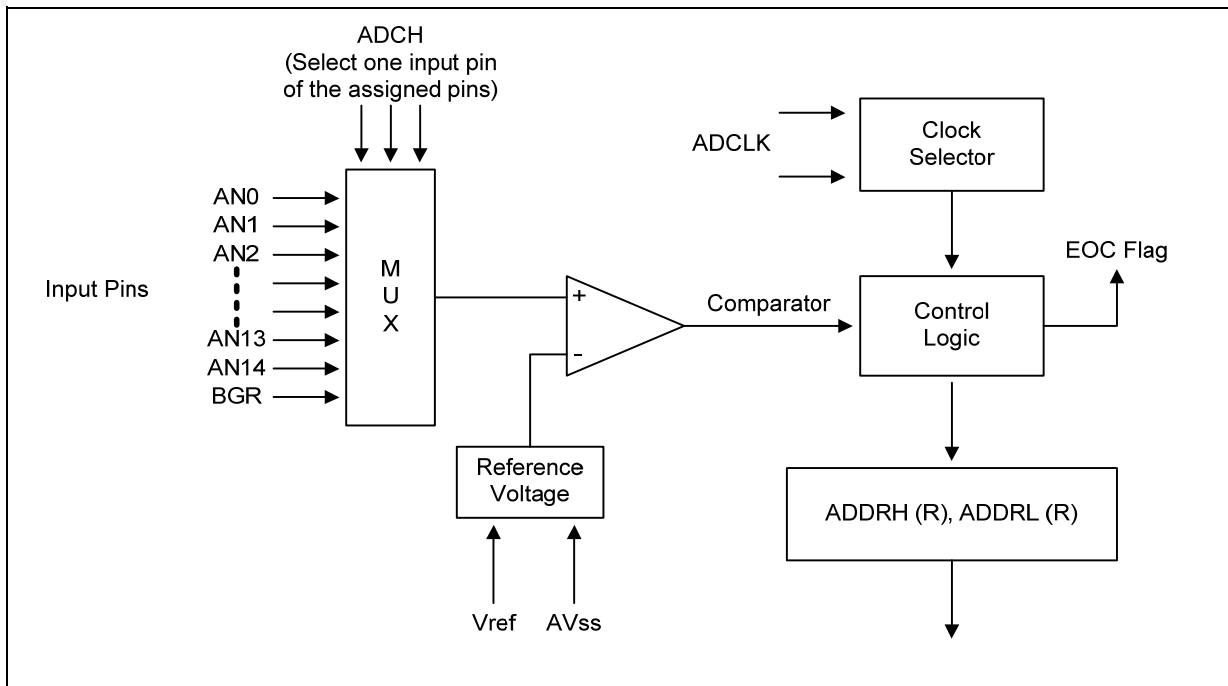

Figure 22-1 A/D Converter Block Diagram

The 12-bit A/D converter (ADC) module uses successive approximation logic to convert analog levels entering at one of the 16 input channels to equivalent 12-bit digital values. The analog input level must lie between the V_{REF} and V_{SS} values. The A/D converter has the analog comparator with successive approximation logic, D/A converter logic (resistor string type), A/D mode register (ADMR), 16 multiplexed analog data input pins (AD0-AD14,BGR), and 12-bit A/D conversion data output register (ADDRH/ADDRL).

22.1 Registers

ADMR

A/D MODE REGISTER

00BDH

	7	6	5	4	3	2	1	0	
ADMR	SSBIT	EOC	ADCLK		ADCH				Reset value: 00H
	R/W	R	R/W	R/W	R/W	R/W	R/W	R/W	

After reset, the start/stop bit is turned off. You can select only one analog input channel at a time. Other analog input (AD0-AD14,BGR) can be selected dynamically by manipulating the ADCH. And the pins not used for analog input can be used for normal I/O function.

SSBIT	Start or Stop bit	0: Stop operation 1: Start operation	
EOC	End of Conversion	0: Conversion not complete 1: Conversion complete	
ADCLK	A/D Clock Selection	00: fxx/1 01: fxx/2	10: fxx/4 11: fxx/8
ADCH	A/D Input Pin Selection	0000: AN0 0001: AN1 0010: AN2 0011: AN3 0100: AN4 0101: AN5 0110: AN6 0111: AN7	1000: AN8 1001: AN9 1010: AN10 1011: AN11 1100: AN12 1101: AN13 1110: AN14 1111: BGR

ADDRH

A/D CONVERTER DATA HIGH REGISTER

00BEH

	7	6	5	4	3	2	1	0	
ADDRH	.11	.10	.9	.8	.7	.6	.5	.4	Reset value: XXH
	R	R	R	R	R	R	R	R	

A 8-bit data register for higher 8-bits of the 12-bit ADC result.

ADDRL

A/D CONVERTER DATA LOW REGISTER

00BFH

	7	6	5	4	3	2	1	0	
ADDRL	.3	.2	.1	.0	-	-	-	-	Reset value: X-H
	R	R	R	R	R	R	R	R	

A 8-bit data register for lower 4-bits of the 12-bit ADC result.

22.2 Procedure

To do the A/D converting, follow these basic steps:

1. Set the ADC pins as the alternative mode.
2. Set the ADMR register for
 - setting ADC channel
 - setting Clock
 - clearing the 'End of Conversion' bit
 - starting ADC
3. Wait until ADC is finished (check the 'End of Conversion' bit)
When ADC is finished, EOC bit is set and SSBIT is cleared automatically.
4. Read the ADCRH and ADCRL register

To initiate an analog-to-digital conversion procedure, at first you must set ADC pins to alternative function (ADC analog input) mode. And you write the channel selection data in the A/D mode register (ADMR) to select one of analog input channels and set the conversion start/stop bit, SSBIT. The pins not used for ADC can be used for normal I/O.

To start the A/D conversion, you should set the start/stop bit, SSBIT. When a conversion is completed, the end-of-conversion bit, EOC is automatically set to 1 and the result is dumped into the ADDRH/ADDRL register. Then the A/D converter enters an idle state. The EOC bit is cleared when SSBIT is set.

Note that, ADC interrupt is not provided.

Because the A/D converter has no sample-and-hold circuitry, it is very important that fluctuation of the analog level at the ADC input pins during a conversion procedure be kept to an absolute minimum. Any change in the input level, perhaps due to noise, will invalidate the result.
If the chip enters to STOP or IDLE mode in conversion process, there will be a leakage current path in A/D block. You must use STOP or IDLE mode after ADC operation is finished.

22.3 Conversion Timing

The A/D conversion process requires 4 steps (4 clock edges) to convert each bit and 10 clocks to set-up A/D conversion. Therefore, total of 66 clocks are required to complete a 12-bit conversion: When f_{clk}/8 is selected for conversion clock with a 12 MHz f_{clk} clock frequency, one clock cycle is 0.66 μs. Each bit conversion requires 4 clocks, the conversion rate is calculated as follows:

$4 \text{ clocks/bit} \times 14 \text{ bits} + \text{set-up time} = 66 \text{ clocks}$, $66 \text{ clock} \times 0.66 \mu\text{s} = 44.0 \mu\text{s}$ at 1.5 MHz (12 MHz/8)

Note : The A/D converter needs at least 25 μs for conversion time. So you must set the conversion time slower than 25 μs.

22.4 Internal Reference Voltage

In the ADC function block, the analog input voltage level is compared to the reference voltage. The analog input level must be remained within the range V_{SS} to V_{REF} .

Different reference voltage levels are generated internally along the resistor tree during the analog conversion process for each conversion step. The reference voltage level for the first conversion bit is always $1/2 V_{REF}$.

22.5 Recommended Circuit

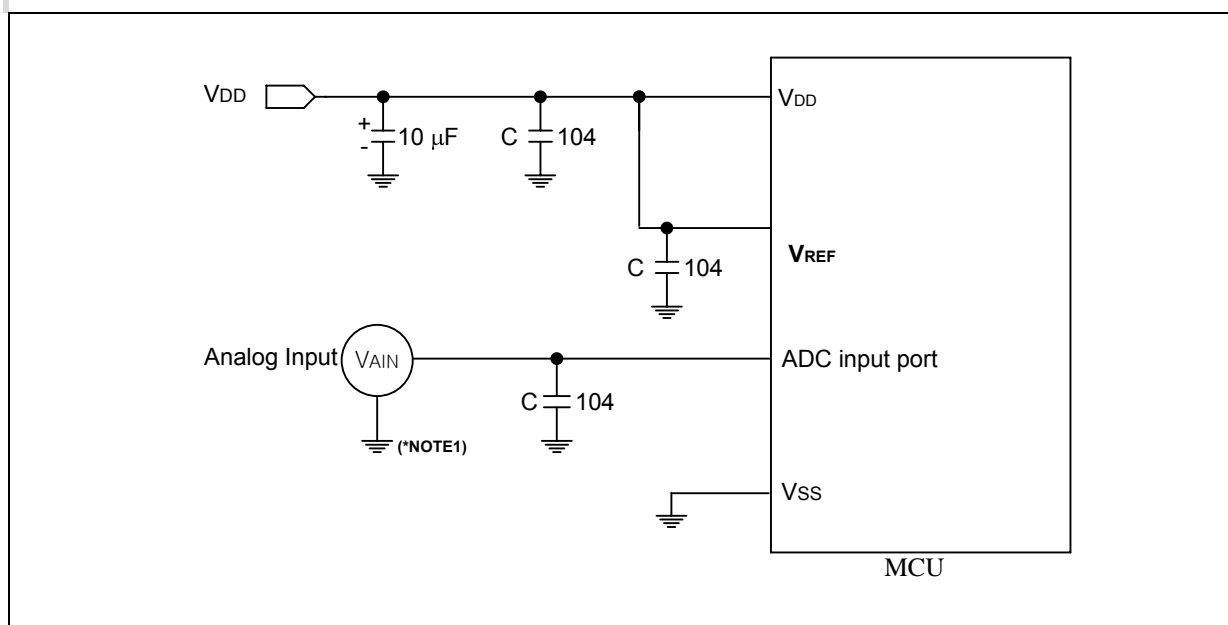

Figure 22-2 Recommended A/D Converter Circuit

Note: Lay out the GND of V_{AIN} as close as possible to the power source.

23. SERIAL I/O INTERFACE

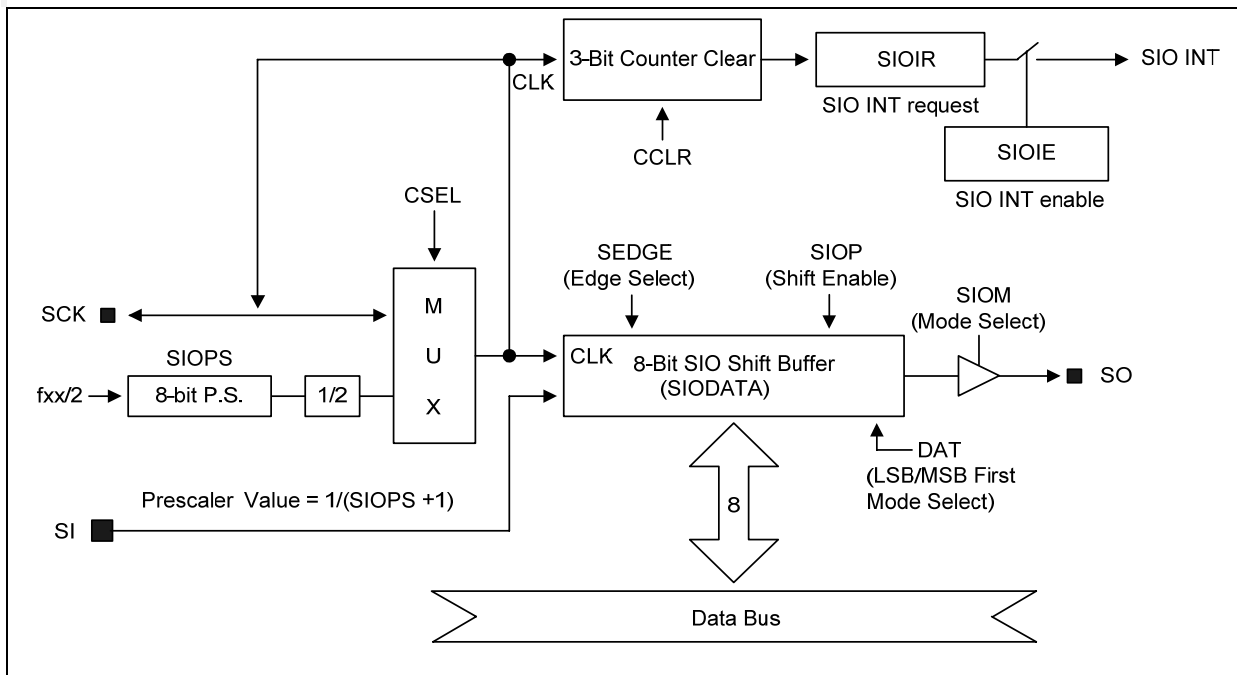

Figure 23-1 SIO Block Diagram

Serial I/O interface modules, SIO can interface with various types of external device that require serial data transfer. The components of SIO function block are:

- 8-bit control register (SIOCR)
- Clock selector logic
- 8-bit data register (SIODAT)
- 8-bit pre-scaler register (SIOPS)
- 3-bit clock counter
- Serial data I/O pins (SI, SO)
- Serial clock pin (SCK)

The SIO module can transmit or receive 8-bit serial data at a frequency determined by its corresponding control register settings. To ensure flexible data transmission rates, you can select internal or external clock source.

23.1 Registers

SIOCR

SERIAL I/O INTERFACE CONTROL REGISTER

00E7H

A reset clears the SIOCR register value to "00H". With this value, internal clock source and receive-only mode are selected and the 3-bit counter is cleared. The data shift operation is disabled. The selected data direction is MSB-first.

	7	6	5	4	3	2	1	0	
SIOCR	–	–	CSEL	DAT	SIOM	SIOP	CCLR	SEDGE	Reset value:
	–	–	R/W	R/W	R/W	R/W	R/W	R/W	--00_0000b

–	bit7 – bit6	Not used for MC81F4432
CSEL	SIO Shift Clock Selection Bit	0: Internal clock (P.S clock) 1: External clock (SCK)
DAT	Data Direction Control Bit	0: MSB-first mode 1: LSB-first mode
SIOM	SIO Mode Selection Bit	0: Receive only mode 1: Transmit/Receive mode
SIOP	SIO Shift Operation Enable Bit	0: Disable shifter and clock counter 1: Enable shifter and clock counter
CCLR	SIO Counter Clear and Shift Start Bit	0: No action 1: Clear 3-bit counter and start shifting
SEDGE	Shift Clock Edge Selection Bit	0: Tx at falling edges, Rx at rising edges 1: Tx at rising edges, Rx at falling edges

SIODAT

SIO DATA REGISTER

00E8H

	7	6	5	4	3	2	1	0	
SIODAT	One byte register								Reset value: 00H
	R/W	R/W	R/W	R/W	R/W	R/W	R/W	R/W	

A 8-bit data register for SIO Rx/Tx data

SIOPS

SIO PRE-SCALER REGISTER

00E9H

	7	6	5	4	3	2	1	0	
SIOPS	One byte register								Reset value: 00H
	R/W	R/W	R/W	R/W	R/W	R/W	R/W	R/W	

$$\text{Baud rate} = (\text{fxx}/4) / (\text{SIOPS}+1)$$

23.2 Procedure

To program the SIO module, follow these basic steps:

1. Configure the I/O pins at port (SCK/SI/SO) by loading the appropriate value to the R0CONM, R0CONH register if necessary.
 - If one side uses a internal clock, the other side must use a external clock.
 - Note that, if the external clock is used, you must set the SCK port as an input mode.
2. Set SIOPS register with proper pre-scale value.
3. Load an 8-bit value to the SIOCR to properly configure the serial I/O module. In this operation, SIOP [SIOCR.2] bit must be set to "1" to enable the data shifter.
4. For interrupt generation, set the SIO interrupt enable bit, SIOIE to "1".
5. Data transmit and receiving are occurred at the same time. So before start the shift operation, you must set the SIODAT with what you want to transmit.
 - When SIOM [SIOCR.3] bit is 0, it does not transmit a data.
6. When set SIOCR.1 to 1, the shift operation starts.
 - With internal clock: shift operation is started right after SIOCR.1 is set.
 - With external clock: shift operation is started when the master starts the operation.
7. When the shift operation (transmit/receive) is completed, the SIO interrupt request flag bit, SIOIR is set to "1" and SIO interrupt request is generated.
 - Don't forget to set the SIOCR.1 bit by 1, to receive next SIO data if want.

When the SIO interrupt sub-routine is serviced, the SIO interrupt request flag bit, SIOIR, is cleared automatically.

24. UART

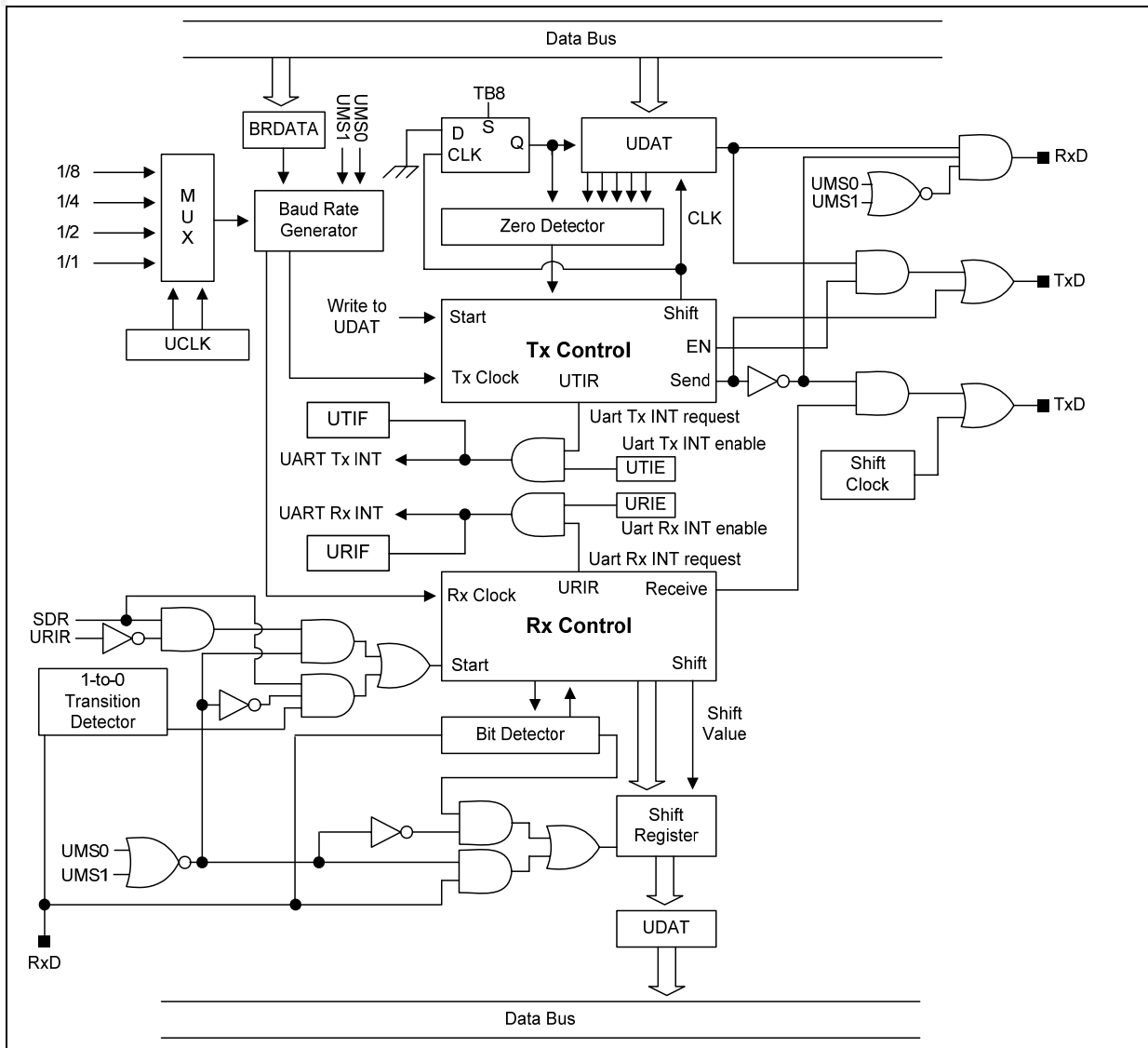

Figure 24-1 UART Block Diagram

The UART block has four communication modes. One synchronous mode and three UART (Universal Asynchronous Receiver/Transmitter) modes.

- Mode 0 : Serial I/O with baud rate of $f_{xx}/(16 \times (BRDAT+1))$ half-duplex and master mode only
- Mode 1 : 8-bit UART mode; variable baud rate : no parity bit
- Mode 2 : 9-bit UART mode; $f_{xx}/16$
- Mode 3 : 9-bit UART mode, variable baud rate

24.1 Registers

UCONH

UART CONTROL HIGH REGISTER (UCONH)

00FCH

When current mode is 2 or 3, and the 'MCE' bit is enabled, Rx interrupt is generated when only 9th bit of Rx data is '1'. This feature is used to Multiprocessor Communication. See '24.4 Multi-processor Communication' on page 175 for more detail information.

In mode 1, and the 'MCE' bit is enabled, Rx interrupt is generated when only valid stop bit is received. In mode 0, the 'MCE' bit must be '0'.

TB8 and RB8 bits are ignored when current mode is 0 or 1, or the 'UTP(UCONL.7 / UART parity auto-generation)' bit is enabled.

	7	6	5	4	3	2	1	0	
UCONH	UMS1	UMS0	MCE	SDR	TB8	RB8	-	-	Reset value: 00H
	R/W	R/W	R/W	R/W	R/W	R/W	-	-	

UMS	UART Mode Selection Bits	00: Mode 0; Synchronous mode ($fu/(16 \times (BRDAT+1))$) 01: Mode 1; 8-bit UART ($fu/(16 \times (BRDAT+1))$) 10: Mode 2; 9-bit UART ($fx/16$) 11: Mode 3; 9-bit UART ($fu/(16 \times (BRDAT+1))$)
MCE	Multiprocessor Communication Enable Bit (for modes 2 and 3 only)	0: Disable 1: Enable
SDR	Serial Data Receive Enable Bit	0: Receive Disable 1: Receive Enable
TB8	TB8	9th bit of Tx Data
RB8	RB8	9th bit of Rx Data
-	bit1 – bit0	Not used for MC81F4x16

Note : 'fu' is the clock source which is selected by the UCLK(UCONL.[2-3]) bits.

UCONL**UART CONTROL LOW REGISTER****00FDH**

	7	6	5	4	3	2	1	0	
UCONL	UTP	UTPS	URPS	URPER	UCLK		-	-	Reset value: 00H
	R/W	R/W	R/W	R/W	R/W	R/W	-	-	

UTP	UART Transmit Parity-bit Auto-Generation Enable Bit	0: Disable parity-bit auto-generation 1: Enable parity-bit auto-generation
UTPS	UART Transmit Parity-bit Selection Bit (for modes 2 and 3 only)	0: Even parity-bit 1: Odd parity-bit
URPS	UART Receive Parity-bit Selection Bit (for modes 2 and 3 only)	0: Even parity-bit check 1: Odd parity-bit check
URPER	UART Receive Parity-bit Error Status Bit (for modes 2 and 3 only)	0: No parity-bit error 1: Parity-bit error
UCLK	UART Clock Selection Bits	00: fxx/8 01: fxx/4 10: fxx/2 11: fxx/1
-	bit1 – bit0	Not used for MC81F4x16

UDAT**UART DATA REGISTER****00FEH**

Both UART receive and transmit buffers are both accessed via the UDAT register even two buffers are physically separated. Writing to the UDAT register accesses the transmit buffer; reading the UDAT register accesses the receive buffer.

	7	6	5	4	3	2	1	0	
UDAT	One byte register								Reset value: XXH
	R/W	R/W	R/W	R/W	R/W	R/W	R/W	R/W	

A 8-bit data register for UART Rx/Tx data

BRDAT**UART BAUD RATE DATA REGISTER****00FFH**

	7	6	5	4	3	2	1	0	
BRDAT	One byte register								Reset value: FFH
	R/W	R/W	R/W	R/W	R/W	R/W	R/W	R/W	

A 8-bit data register for UART baud rate setting

24.2 Modes and Procedures

Uart Mode 0

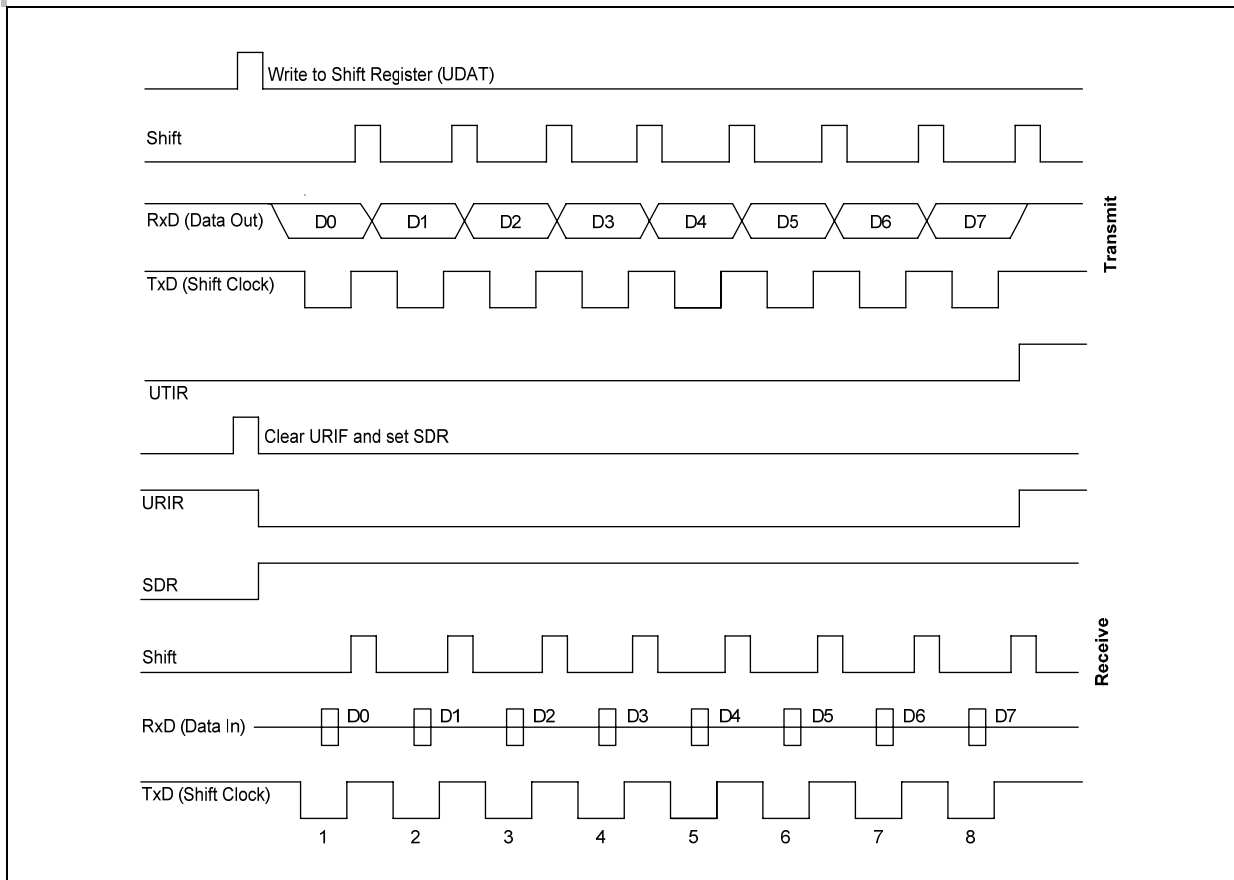

Figure 24-2 Timing Diagram for Serial Port Mode 0 Operation

In mode 0, both input and output data are passed through the RxD (R14) pin and TxD (R15) pin generates the clock. Data is transmitted or received in 8-bit units only. The LSB of the 8-bit value is transmitted (or received) first.

Note that, only master mode is provided.

Mode 0 Transmit Procedure

1. Set Rx/Tx pins to Alternative mode.
2. Set the baud rate
 - Select the UART clock by setting the UCLK(UCONL.[3-2]) bits.
 - Set the BRDAT register properly
3. Select mode 0 by setting the USM(UCONH.[7-6]) bits.
4. Write transmission data to the UDA.

After finish above steps, the data transmission will be started. And after finish the transmission, both UTIR(IRQL.3) and UTIF(INTFL.0) bits are set to '1' by hardware.

Mode 0 Receive Procedure

1. Set the baud rate
 - Select the UART clock by setting the UCLK(UCONL.[3-2]) bits.
 - Set the BRDAT register properly
2. Select mode 0 by setting the USM(UCONH.[7-6]) bits.
3. Clear the receive interrupt request flag bit URIR(IRQL.4).
4. Set the SDR(UCONH.4 / UART receive enable bit) by '1'.

Right after finish above steps, the shift clock will be output to the TxD (R15) pin and receiving is started at the RxD (R14) pin. After finish receiving, both URIR(IRQL.4) and URIF(INTFL.1) bits are set to "1" by hardware.

Uart Mode 1

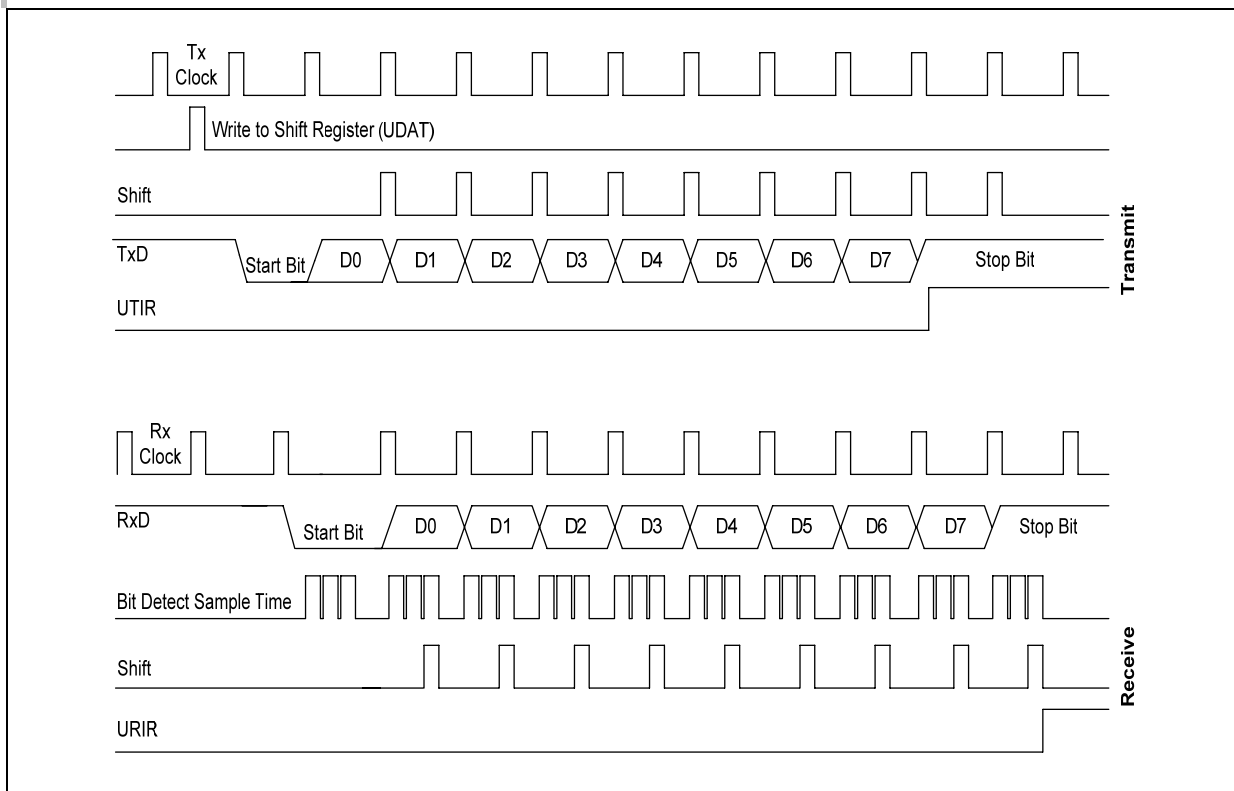

Figure 24-3 Timing Diagram for UART Mode 1 Operation

In mode 1, 10-bits are transmitted (through the TxD (R15) pin) or received (through the RxD (R14) pin). Each data frame has three components:

- Start bit ("0")
- 8 data bits (LSB first)
- Stop bit ("1")

* The baud rate for mode 1 is variable depend on the BRDAT register value.

* Parity bit is not available for mode 1.(mode 2,3 provide parity bit)

Mode 1 Transmit Procedure

1. Set Rx pin to input mode and Tx pin to alternative mode.
2. Set the baud rate
 - Select the UART clock by setting the UCLK(UCONL.[3-2]) bits.
 - Set the BRDAT register properly
3. Select mode 1 by setting the USM(UCONH.[7-6]) bits.
4. Write transmission data to the UDAT.

After finish above steps, the data transmission will be started. And after finish the transmission, the UTIR(IRQL.3) bit is set to '1' by hardware.

Mode 1 Receive Procedure

1. Set Rx pin to input mode and Tx pin to alternative mode.
2. Set the baud rate
 - Select the UART clock by setting the UCLK(UCONL.[3-2]) bits.
 - Set the BRDAT register properly
3. Select mode 1 by setting the USM(UCONH.[7-6]) bits and set the SDR (UCONH.4 / Receive Enable) bit in the UCONH register to "1".

After finish above steps, the receive operation starts when the signal at the RxD (R14) pin goes to low level(start bit). After finish receiving, the URIR(IRQL.4) is set to "1".

Uart Mode 2 / 3

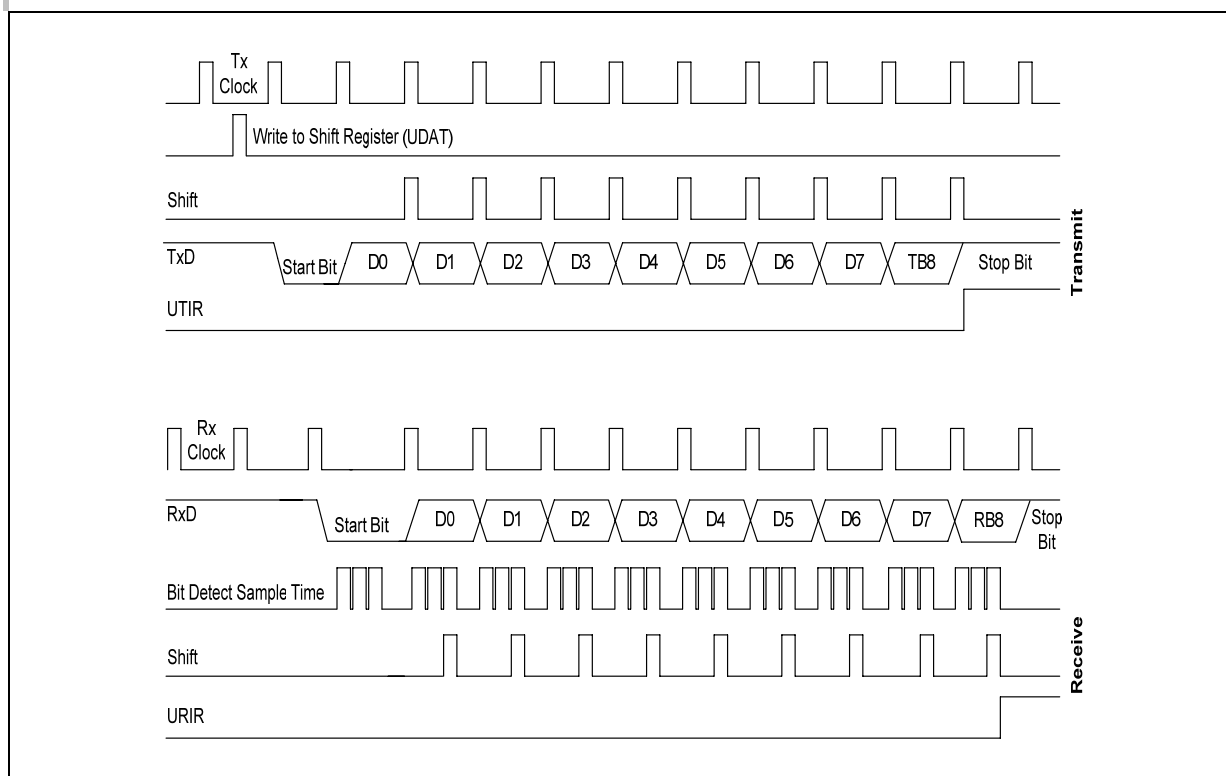

Figure 24-4 Timing Diagram for UART Mode 2 and 3 Operation

The mode 2 is exactly same with mode 3 when the BRDAT register value is '00h'. In mode 2 the BRDAT is assumed '00h' even whatever value is stored in the BRDAT register. But in mode 3, the baud rate is changeable by the BRDAT register.

In mode 2 and 3, 11-bits are transmitted (through the TxD (R15) pin) or received (through the RxD (R14) pin). Each data frame has four components:

- Start bit ("0")
- 8 data bits (LSB first)
- Programmable 9th data bit
- Stop bit ("1")

The 9th data bit to be transmitted can be assigned a value of "0" or "1" by writing the TB8(UCONH.3) bit. When receiving, the 9th data bit that is received is written to the RB8(UCONH.2) bit, while the stop bit is ignored.

The baud rate for mode 2 is $f_u/16$ (BRDAT is ignored in mode 2).

The baud rate for mode 3 is $f_u/(16 \times (BRDAT+1))$.

Mode 2 / 3 Transmit Procedure

1. Set Rx pin to input mode and Tx pin to alternative mode.
2. Set the baud rate
 - Select the UART clock by setting the UCLK(UCONL.[3-2]) bits.
 - Set the BRDAT register properly(in mode 3 only)
3. Select mode 2 or 3 by setting the USM(UCONH.[7-6]) bits.
4. Set the 9th bit, there are two way to set the 9th bit.
 - Set the 'UTP(UCONL.7 / parity auto-generatio)' bit by '1'
 - Or, Clear 'UTP(UCONL.7 / parity auto-generation)' bit by '0' and write the 9th bit data to the TB8(UCONH.3) bit as you want.
5. Write transmission data to the UDAT.

After finish above steps, the data transmission will be started. And after finish the transmission, the UTIR(IRQL.3) bit is set to '1' by hardware.

Mode 2 / 3 Receive Procedure

1. Set Rx pin to input mode and Tx pin to alternative mode.
2. Set the baud rate
 - Select the UART clock by setting the UCLK(UCONL.[3-2]) bits.
 - Set the BRDAT register properly(in mode 3 only)
3. Select mode 2 or 3 by setting the USM(UCONH.[7-6]) bits.
4. If you want, set the MCE(UCONH.5 / multi-processor communication enable) bit
If you do not want the MCE feature, do not have to set the MCE bit.
5. Set the SDR(UCONH.4 / receive enable) bit by '1'.
- 6.

After finish above steps, the receive operation starts when the signal at the RxD (R14) pin goes to low level(start bit). After finish receiving, the URIR(IRQL.4) is set to "1".

24.3 Baud rate calculations

Mode 2

The baud rate in mode 2 is fixed at the fxx clock frequency divided by 16:

Mode 2 baud rate = fxx/16

Modes 0, 1 and 3

In modes 0, 1 and 3, the baud rate is determined by the UART baud rate data register, BRDAT:

Mode 0, 1 and 3 baud rate = fu/(16 × (BRDATA + 1))

Mode	Baud Rate	UART Clock	BRDAT	
			DEC	HEX
Mode 2	0.5 MHz	8 MHz	X	X
	230,400 Hz	11.0592 MHz	02	02H
	115,200 Hz	11.0592 MHz	05	05H
	57,600 Hz	11.0592 MHz	11	0BH
	38,400 Hz	11.0592 MHz	17	11H
	19,200 Hz	11.0592 MHz	35	23H
	9,600 Hz	11.0592 MHz	71	47H
	4,800 Hz	11.0592 MHz	143	8FH
	62,500 Hz	10 MHz	09	09H
	9,615 Hz	10 MHz	64	40H
	38,461 Hz	8 MHz	12	0CH
	12,500 Hz	8 MHz	39	27H
	19,230 Hz	4 MHz	12	0CH
	9,615 Hz	4 MHz	25	19H

Figure 24-5 Commonly Used Baud Rates Generated by BRDAT

24.4 Multi-processor Communication

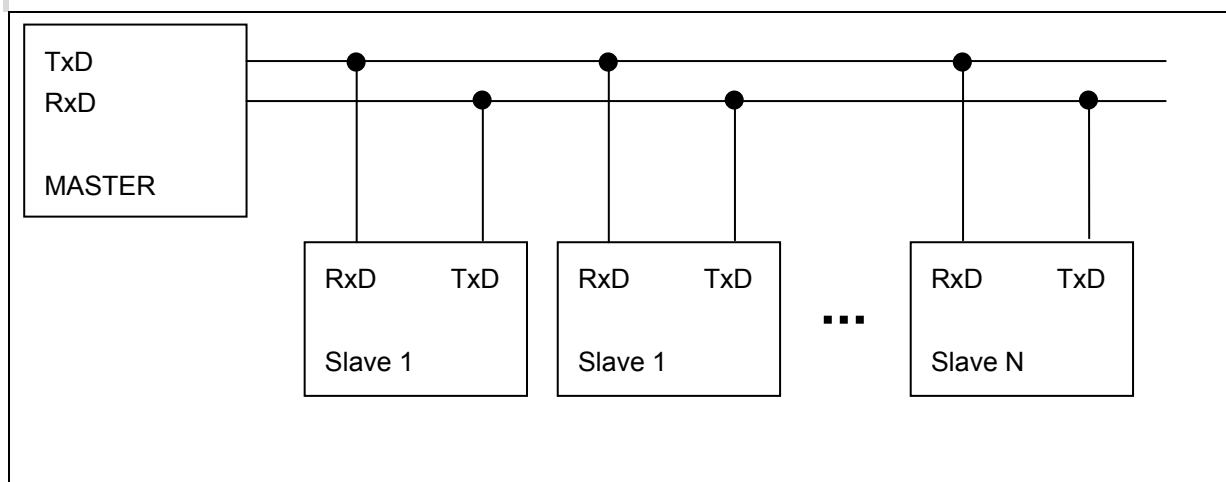

Figure 24-6 Connection Example for Multiprocessor Serial Data Communications

The MC81F4x16 multiprocessor communication features lets a "master" device send a multiple-frame serial message to a "slave" device in a multi-processor configuration. It does this without interrupting other slave devices that may be on the same serial line.

This feature can be used only in UART modes 2 or 3. In these modes 2 and 3, 9 data bits are received. The 9th bit value is written to RB8 (UCONH.2). The data receive operation is concluded with a stop bit. You can program this function so that when the stop bit is received, the serial interrupt will be generated only if RB8 = "1".

To enable this feature, you set the MCE bit in the UCONH register. When the MCE bit is "1", serial data frames that are received with the 9th bit = "0" do not generate an interrupt. In this case, the 9th bit simply separates the address from the serial data.

Sample Protocol for Master/Slave Interaction

When the master device wants to transmit a block of data to one of several slaves on a serial line, it first sends out an address byte to identify the target slave. Note that in this case, an address byte differs from a data byte: In an address byte, the 9th bit is "1" and in a data byte, it is "0".

The address byte interrupts all slaves so that each slave can examine the received byte and see if it is being addressed. The addressed slave then clears its MCE bit and prepares to receive incoming data bytes.

The MCE bits of slaves that were not addressed remain set, and they continue operating normally while ignoring the incoming data bytes.

While the MCE bit setting has no effect in mode 0, it can be used in mode 1 to check the validity of the stop bit. For mode 1 reception, if MCE is "1", the receive interrupt will be issue unless a valid stop bit is received.

Setup Procedure for Multiprocessor Communications

Follow these steps to configure multiprocessor communications:

1. Set all MC81F4x16 devices (masters and slaves) to UART mode 2 or 3.
2. Write the MCE bit of all the slave devices to "1".
3. The master device's transmission protocol is:
 - First byte: the address identifying the target slave device (9th bit = "1")
 - Next bytes: data (9th bit = "0")
4. When the target slave receives the first byte, all of the slaves are interrupted because the 9th data bit is "1". The targeted slave compares the address byte to its own address and then clears its MCE bit in order to receive incoming data. The other slaves continue operating normally.

24.5 Interrupt

Interrupt Timing

In mode 0, the URIR(IRQL.4) bit is set to "1" when the 8th receive data bit has been shifted. In mode 1, the URIR(IRQL.4) bit is set to "1" at the halfway point of the stop bit's shift time.

In mode 2, or 3, the URIR(IRQL.4) bit is set to "1" at the halfway point of the RB8 bit's shift time. When the CPU has acknowledged the receive interrupt request flag condition, the URIR(IRQL.4) bit is cleared automatically.

In mode 0, the UTIR(IRQL.3) bit is set to "1" when the 8th transmit data bit has been shifted. In mode 1, 2, or 3, the UTIR(IRQL.3) bit is set at the start of the stop bit. When the CPU has acknowledged the transmit interrupt request flag condition, the UTIR(IRQL.3) 4 bit is cleared automatically.

Shared Interrupt Vector

In case of using interrupts of UART Tx and UART Rx together, it is necessary to check UTIF and URIF in interrupt service routine to find out which interrupt is occurred, because the UART Tx and UART Rx is shared with the same interrupt vector address. These flag bits must be cleared by software after reading this register. (UTIF and URIF are placed in INTFL register. See '9.6 Control Registers (SFR)' on page 71)

25. SLAVE IIC

IIC is used to communicate between some devices with 2 lines which are SDA(Serial Data Line) and SCL(Serial Clock Line). Both two lines are bidirectional open drain lines which are pulled up with registers.

IIC provides 'standard mode' (max 100Kbps) and 'fast mode' (max 400Kbps).

25.1 Roles

There are two roles in an IIC communication. Which are 'master' and 'slave'.

- Master : that generates the clock and transfer slave's address.
- Slave : that receives the clock and matched with message's slave address.

Note: MC81F4x16 provides the slave mode only.

25.2 Registers

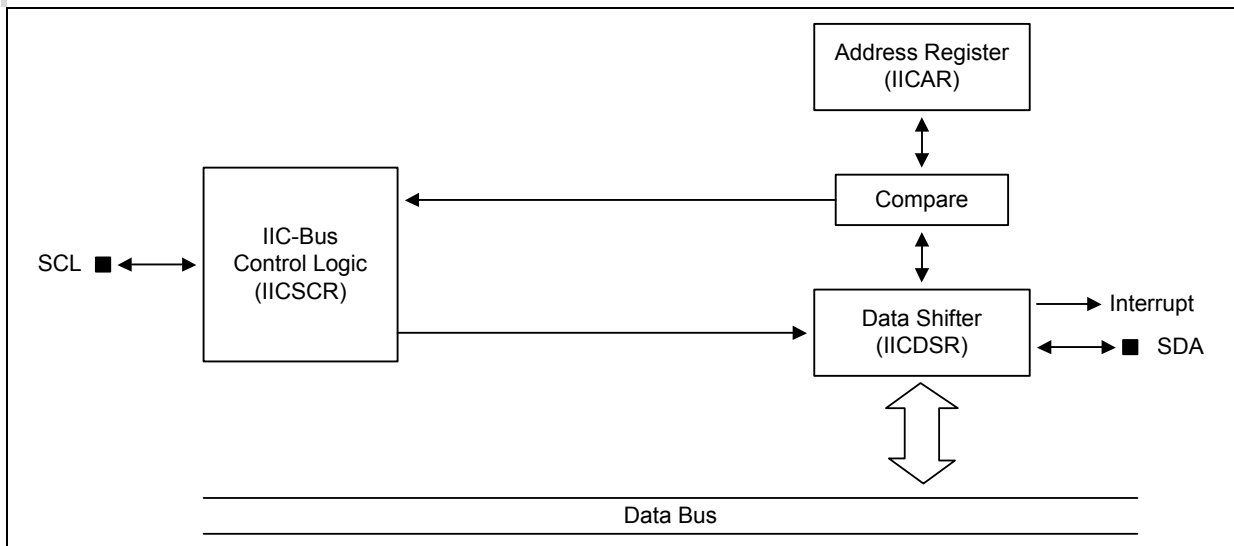

Figure 25-1 Registers for IIC

IICSCR

SLAVE IIC STATUS AND CONTROL REGISTER

00E2H

	7	6	5	4	3	2	1	0	
IICSCR	ACKE	IICEN	IICIFEN	IICAZS	IICTR	IICBS	SAM	IICLR	Reset value: 00H
	R/W	R/W	R/W	R	R/W	R	R	R	

ACKE	IIC-Bus Acknowledgement Enable Bit	0: Disable ACK generation 1: Enable ACK generation
IICEN	IIC-Bus Module Enable Bit	0: Disable IIC-Bus module 1: Enable IIC-Bus module
IICIFEN	IICIF Enable/Disable Bit	0: IICIF (interrupt flag) cannot be generated and IIC interrupt is disabled. 1: IICIF (interrupt flag) can be generated and IIC interrupt is also enabled.
IICAZS	IIC-Bus Address Zero Status Flag	0: It is cleared when start or stop condition is generated. 1: It is set when received slave address is 00H (general call)
IICTR	Slave IIC-Bus Tx/Rx mode Status Bit	It is set or cleared by W/R signal from the master. 0: Slave Receive mode 1: Slave transmit mode
IICBS	IIC-Bus Busy Status Bit	0: IIC-bus is not busy (It is cleared when 'stop' condition is received). 1: IIC-bus is busy (It is set when 'start' condition is received).
SAM	Slave Address Match Bit	0: It is cleared when start or stop or reset condition is generation 1: When received slave address value matches to 'SIAR' register
IICLR	IIC-Bus Last Received Bit Status Bit	0: Last-received 9th bit is "0" (ACK was received) 1: Last-received 9th bit is "1" (ACK was not received)

Note : The IICIFEN must be set by '1' to use IIC interrupt. If it is cleared by '0' IIC interrupt is not occurred.
So, in order to use IIC interrupt, both IICIFEN(IICSCR.5) and IICEN(IENL.7) must be set by '1'.

IICDSR

IIC DATA SHIFT REGISTER

00E4H



When only IICSCR.6='1', write operation is enabled. But read operation is possible at anytime, regardless of the current IICSCR.6 bit setting.

A 8 bit register for Tx/Rx data of slave IIC.
 Note that, When only the IICEN(IICSCR.6) bit is enabled, writing to the 'IICAR' is available.
 But reading is possible anytime, regardless of the current IICEN(IICSCR.6) bit status.

IICAR

IIC ADDRESS REGISTER

00E3H

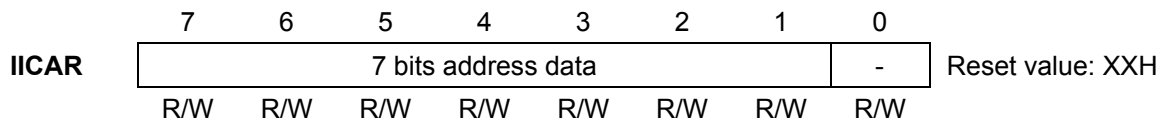

A 8 bit register for the 7 bit slave address.
 Note that, When only the IICEN(IICSCR.6) bit is disabled, writing to the 'IICAR' is available.
 But reading is possible anytime, regardless of the current IICEN(IICSCR.6) bit status.

25.3 Message format

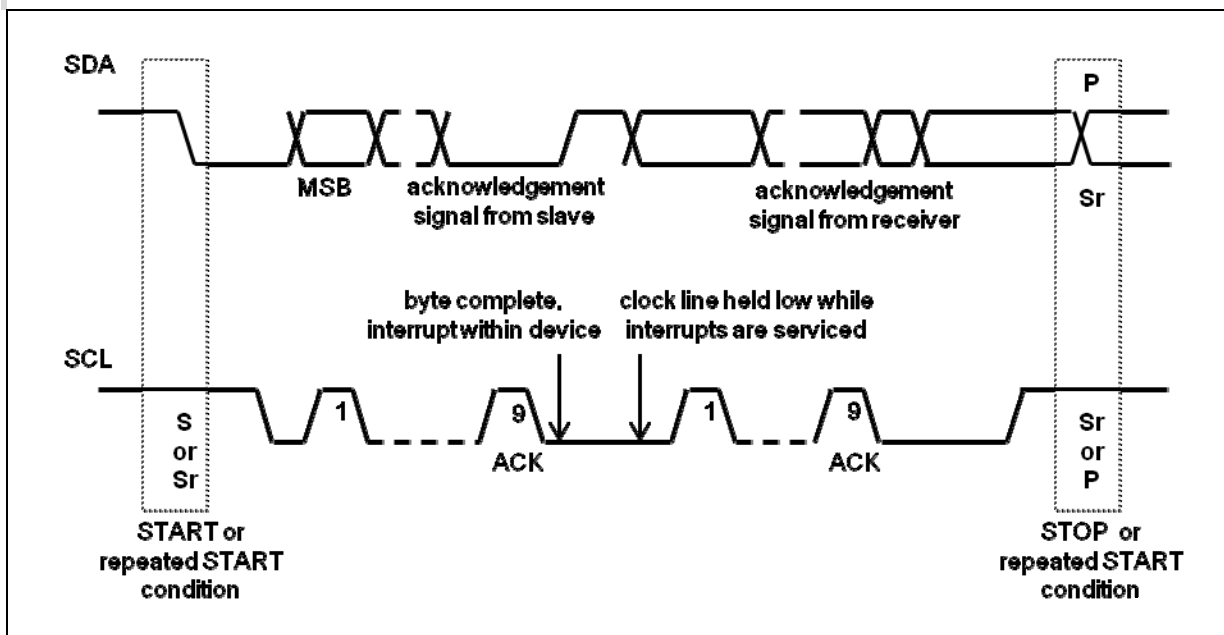

Figure 25-2 Data transfer on the IIC-BUS

START, Repeated START and STOP

One IIC data message is started by 'START condition' and finished by 'STOP' or 'START' condition. If one message is finished by 'START' condition, it means both an end of the current message and a start of the next message at the same time. So we call it 'repeated START condition'.

Repeated START is used to keep the IIC communication bus. If master transmit the STOP condition, other masters can take the bus. To prevent it, the repeated START condition is used.

When SDA(data line) is changed while SCL(clock line) is staying high, it must be one of START, repeated Start or STOP condition. In other words, changing SDA state while SCL is staying high is not possible except those conditions.

START : SDA is changed from HIGH to LOW while SCL is staying high.

STOP : SDA is changed from LOW to HIGH while SCL is staying high.

Repeated START : START condition at the end of the frame.

Message Transmit

After START or repeated START condition, one byte data is transferred from master to slave. The first one byte data consist of 7 bit address and 1 bit read/write flag.

And 1 bit ACK(acknowledge) is transferred from slave to master to notice that receiving process is correctly finished and the slave address is matched.

Note: Simply transmitting '0' is ACK.

After then, one or more data bytes are transferred. The data bytes are sent MSB first.

It is possible both master to slave and slave to master based on the read/write bit flag (the last bit of the first one byte).

Write = read/write bit is 0 = data is transferred from master to slave.

Read = read/write bit is 1 = data is transferred from slave to master.

After each data bytes are transferred, ACK can be transferred from receiver. But meaning is different based on situation.

- Write time : master transmit and slave receive,
slave transmit a ACK when one byte data is correctly received.
So, slave must transmit a ACK when receive is finished.
- Read time : slave transmit and slave receive,
master transmit a ACK when there are more bytes to transmit.
So, if there is no more data to transmit, master dose not transmit a ACK.

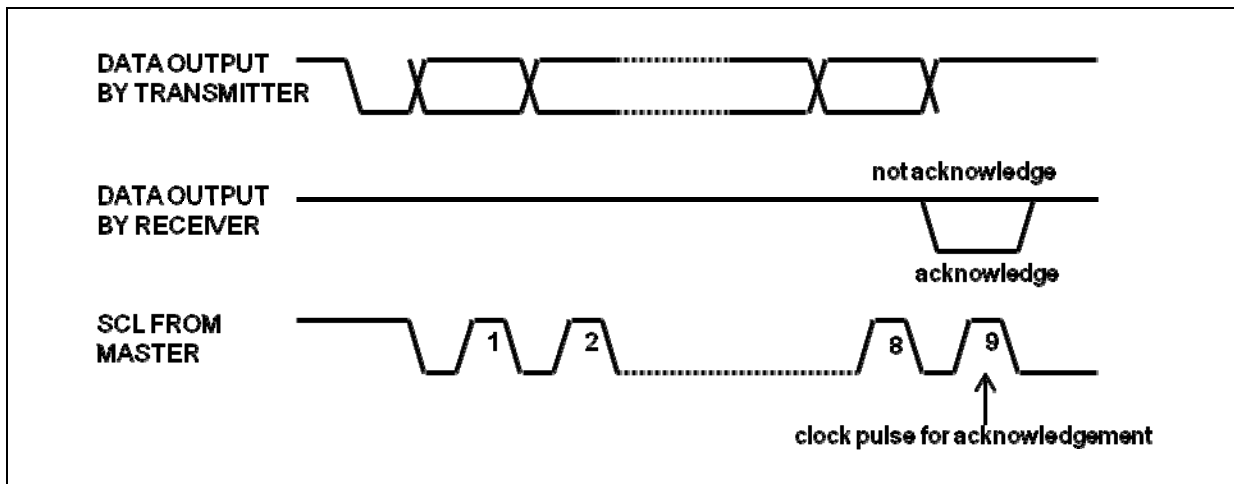

Figure 25-3 Acknowledge on the IIC-BUS

1 Bit Transmit

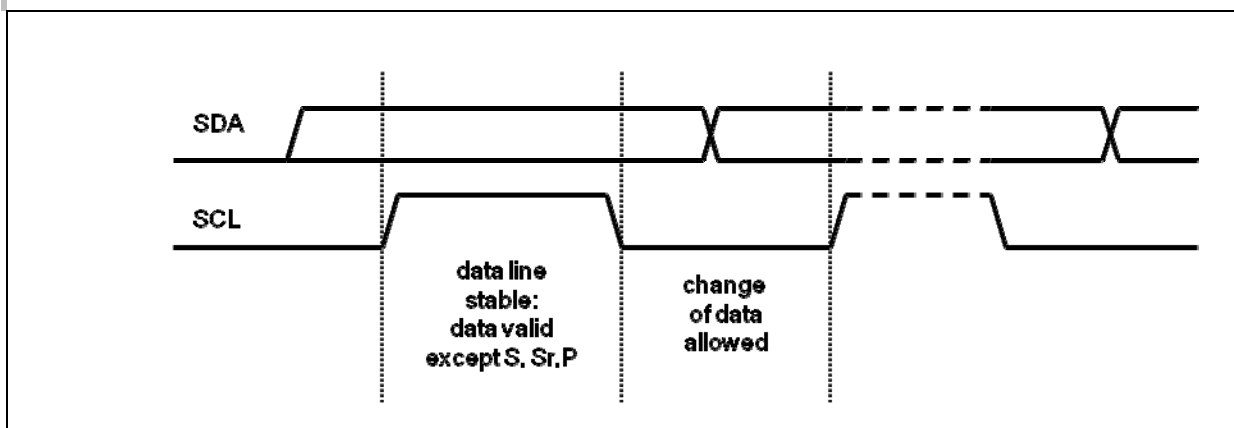

Figure 25-4 Bit transfer on the IIC-BUS

The data bytes and ACK are consist of one bit transmits. If SDA is not changed while SCL is staying high, SDA status is one bit data. As already said, If SDA is changed while SCL is staying high, it is START or STOP condition. Therefore, transfer device change the SDA status while SCL is staying low. And when SCL is going to low, 1 bit transmit is finished.

1 bit data value and state are,

- 1 : high state (more preciously said, line is open-drained and pulled up).
- 0 : low state

25.4 Procedure

Initialization

Following steps initialize the IIC slave.

1. Set SCL and SDA pins as an alternative mode.
Set the R1CONH[7~4] bits by "1010b".
2. Set the slave address by setting the IICAR register.
3. Enable IIC module and the interrupt :
Set the ACKE bit by '1'
Set the IICEN bit by '1'
Set the IICIFEN bit by '1'. (If it is cleared by '0', IIC interrupt is not occurred)
-> Or you can simply set the IICSCR register by 'E0h'.

After finish above steps, IIC interrupt is enabled. So The IIC interrupt will be generated after receive or transmit one byte.

Interrupt Routine Procedure

Simply say, when you write a byte to the IICSCR, it is transmitted and when a byte is received, you can read it from the IICDSR register.

But, the master has a right to decide the read/write mode. And the master sends 1-bit R/W mode flag after 7-bit slave address. And it is stored in the IICTR(IICSCR.3) bit when it is received.

So you can recognize current Rx/Tx mode. And you have to react based on the IICTR(IICSCR.3) bit.

The IICTR(IICSCR.3) bit equals '1' means that the master want to read from the slave. So, In this case, Slave-IIC's mode is changed into 'transmit mode' automatically. So, in this case you have to write a data to the IICDSR register as you want.

The IICTR(IICSCR.3) bit equals '0' means that the master want to write to the slave. So, In this case, Slave-IIC's mode is changed into 'receive mode' automatically. So, in this case you have to read a data from the IICDSR register.

Before finish the IIC interrupt routine, you have to clear the IICIF bit. When the IICIF bit is cleared, the SCL line is released. If it is not cleared, the SCL line is holding down to low status. While in this condition, master can't continue the IIC communication.

In order to recognize current received byte's position in the message, you have to count the IIC interrupts. Based on the position information

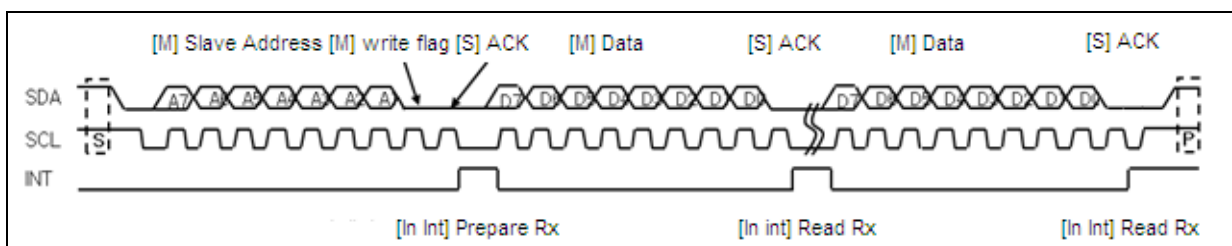

Figure 25-5 IIC Slave Receiving Timing Diagram

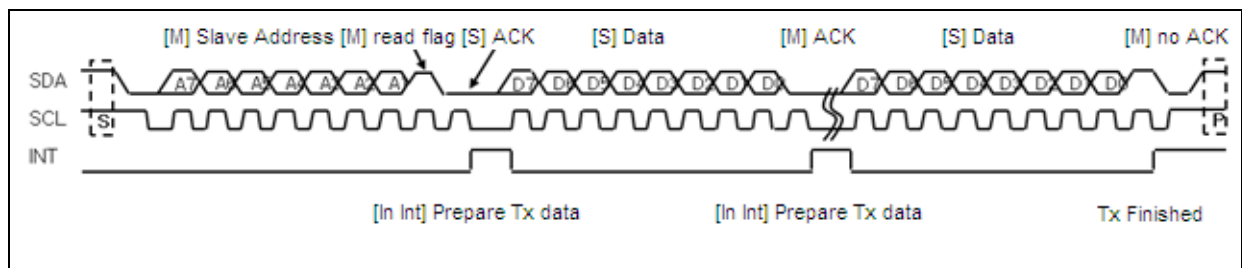

Figure 25-6 IIC Slave Transmit Timing Diagram

26. RESET

26.1 Reset Process

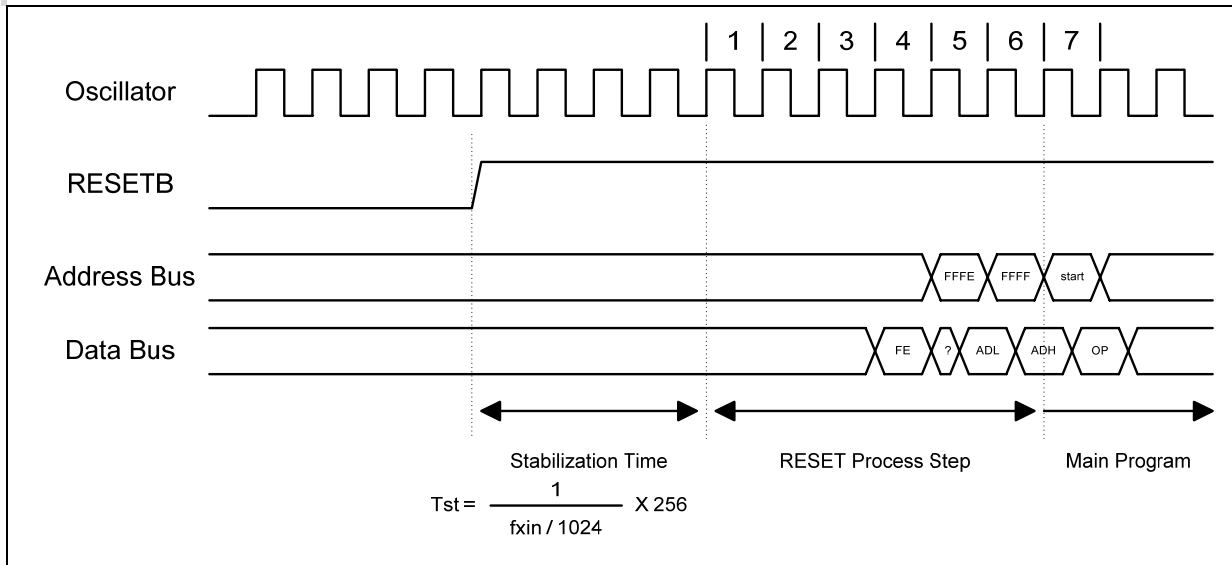

Figure 26-1 Timing Diagram After Reset

When the reset event is occurred, there is a 'stabilization time' at the beginning. This time is counted from 00h to FFh by BIT. So it takes $1/(f_{xin}/1024) * 256$ second.

After that, the 'reset process step' is started. It takes 6 system clock time. At this time, following statuses are initialized.

On- chip Hardware	Initial Value
Program Counter (PC)	high byte = a byte at FFFFh low byte = a byte at FFFEh FFFFh and FFFEh stores the reset vector.
RAM Page Register (PRP)	0
G-flag (G)	0
Operation Mode	OSCS setting of Rom option
Control registers	Initialized by reset values (See '9.6 Control Registers (SFR)' on page 71)
Low Voltage Reset	LVREN setting of Rom option

26-1 Initializing Status by Reset

After that, the main program execution is started from the reset vector address which is stored at FFFFh and FFFEh.

26.2 Reset Sources

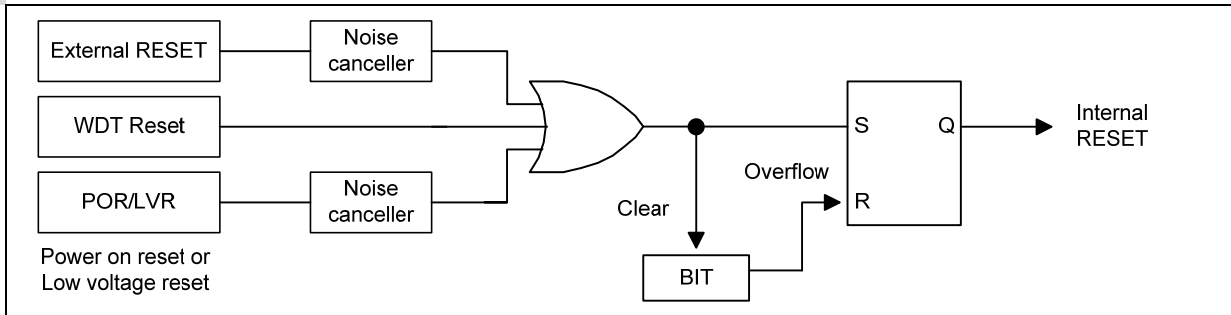

Figure 26-2 Reset Sources Diagram

There are four reset sources in MC81F4x16. Those are external reset, watch dog timer reset, power on reset and low voltage reset.

26.3 Reset circuit

When the external reset is enabled and the input signal of RESET pin is going to low for a while and going to high, the external reset is occurred. (See '7.7 Serial I/O Characteristics' on page 46 for more timing information.)

The Reset Pin should be pulled up to VDD with 75kohm resistor, if reset pin voltage is higher than VDD over 2V gap, MCU process self test procedure

It is possible to use a Reset pin like Figure 26-3..

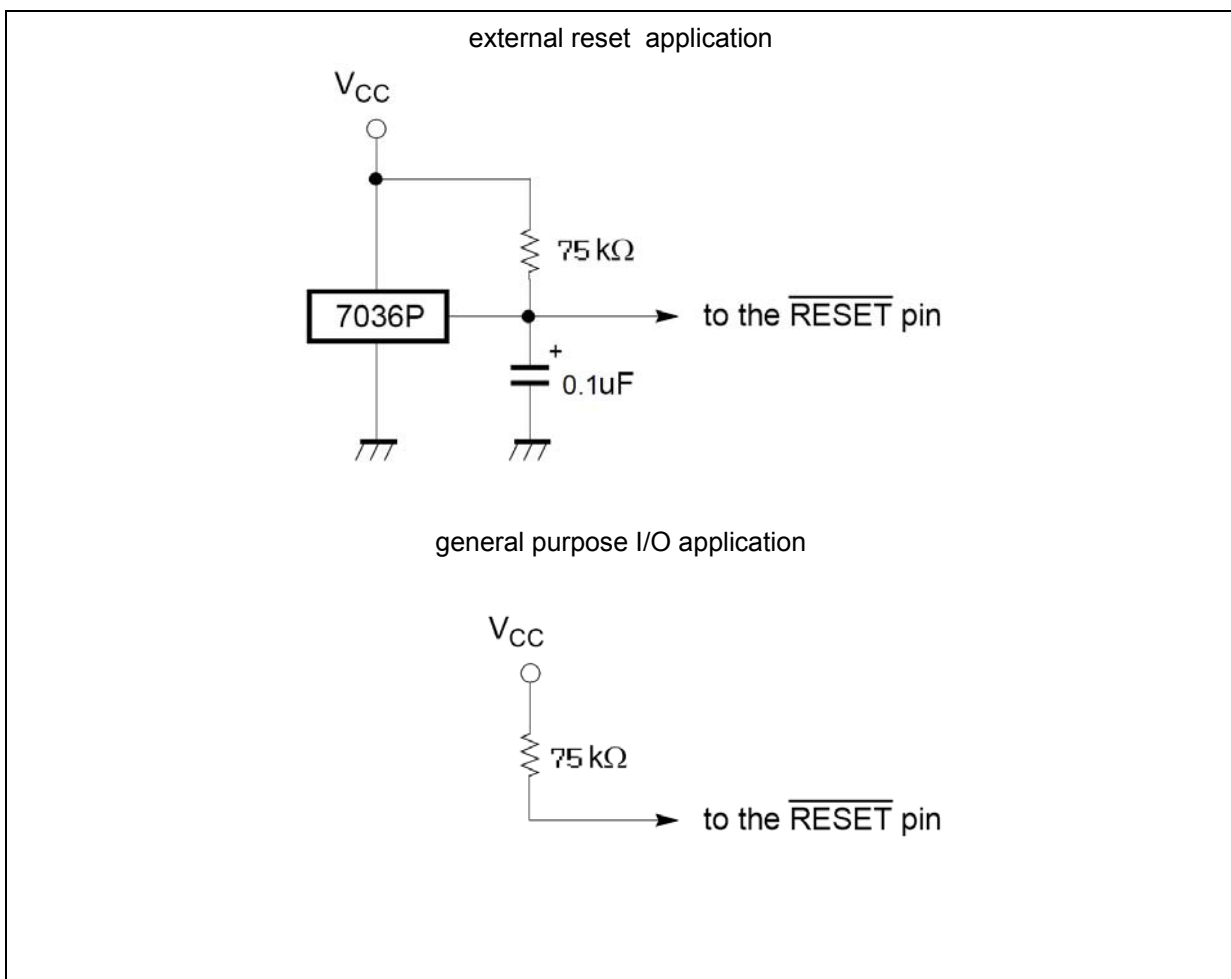

Figure 26-3 Reset circuit Example

26.4 Watch Dog Timer Reset

See '16. WATCH DOG TIMER' on page 125.

26.5 Power On Reset

There is a internal power on reset circuit internally. We simply call it POR. POR occurs the reset event when VDD is rising over the POR level.

Note that, POR can be enabled and disabled by the PORC register. And default setting is 'POR enable'. So at the first time power is supplied, POR is working always even external reset is enabled.

PORC

POWER ON RESET CONTROL REGISTER (00F3H)

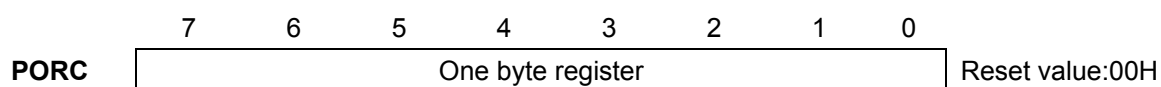

POR Enable/Disable	01011010: POR disable Others: POR enable
--------------------	---

It is recommended to disable the POR. When POR is enabled, current consumption is increased and, the LVR(Low Voltage Reset) is ignored even the LVR is enabled by the 'ROM OPTION'.

26.6 Low Voltage Reset

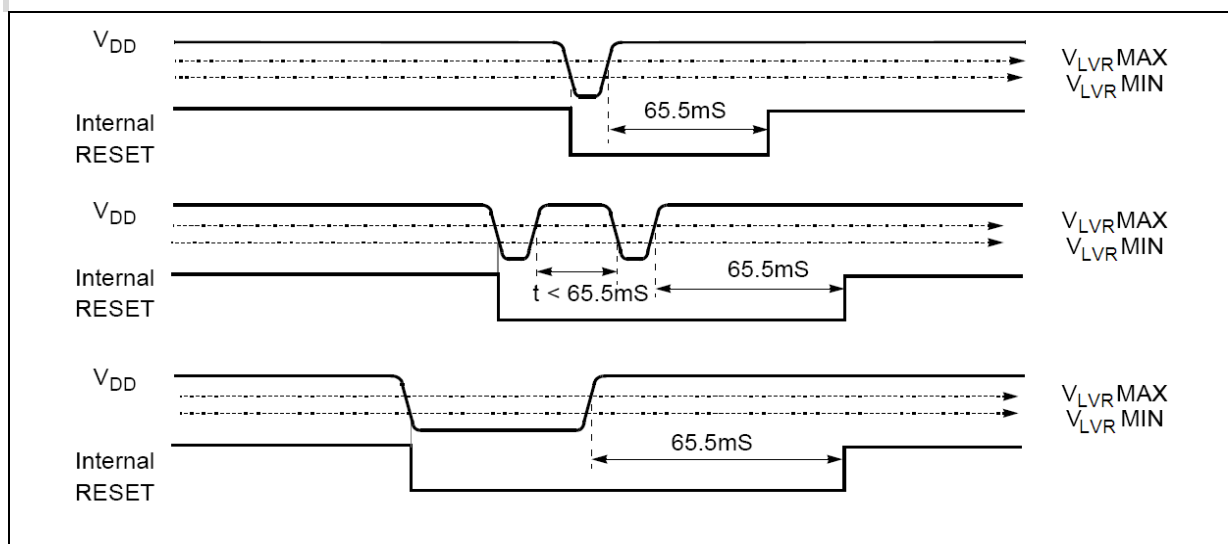

Figure 26-4 LVR Timing Diagram at 4MHz system clock

The low voltage reset occurs the reset event when current VDD is going down under the LVR level. It is configurable by the rom-option. (See '8. ROM OPTION' on page 61)

If you want to know more detail timing information, see '7.9 LVR (Low Voltage Reset) Electrical Characteristics' on page 49.

27. POWER DOWN OPERATION

In the power-down modes, power consumption is reduced considerably. For applications where power consumption is a critical factor, device provides two kinds of power saving functions, STOP mode and SLEEP mode. Table 27-1 on page 112, shows the status of each Power Saving Mode. SLEEP mode is entered by the SSCR register to "0Fh". and STOP mode is entered by STOP instruction after the SSCR register to "5Ah".

Note: ** If you use 20pin package, you must set R12 port as an low OUTPUT mode even it is not exist in 20pin package. **

In fact, R12 port is exist in side of the package and it's reset status is input mode. If it is in input mode it course current leakage when the MCU falls in stop/sleep mode. So you must set it as an output mode before fall in stop/sleep.

It is recommendable to set R12 port as an low OUTPUT mode at initial time.

You do not have to care about it if you use other packages.

27.1 Sleep Mode

In this mode, the internal oscillation circuits remain active. Oscillation continues and peripherals are operated normally but CPU stops. Movement of all peripherals is shown in Table 27-1 on page 112. SLEEP mode is entered by setting the SSCR register to "0Fh". It is released by Reset or interrupt. To be released by interrupt, interrupt should be enabled before SLEEP mode.

SSCR

STOP AND SLEEP CONTROL REGISTER

00F5H

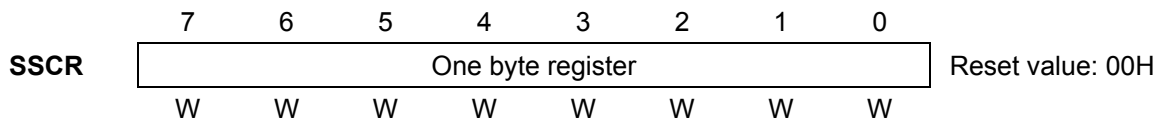

It is used to set the stop or sleep mode.

5Ah : STOP
0Fh : SLEEP

Note: To get into STOP mode, **SSCR must be set to 5AH** just before STOP instruction execution. At STOP mode, Stop & Sleep Control Register (SSCR) value is cleared automatically when released.

To get into SLEEP mode, **SSCR must be set to 0FH**.

Release the SLEEP mode

The exit from SLEEP mode is hardware reset or all interrupts. Reset re-defines all the Control registers but does not change the on-chip RAM (Be careful, If the code is compiled with RAM clear option, RAM is cleared after reset by ram clear routine. It is possible to disable the RAM clear option by option menu). Interrupts allow both on-chip RAM and Control registers to retain their values. If I-

flag = 1, the normal interrupt response takes place. If I-flag = 0, the chip will resume execution starting with the instruction following the SLEEP instruction. It will not vector to interrupt service routine. (refer to Figure 27-3)

When exit from SLEEP mode by reset, enough oscillation stabilization time is required to normal operation. Figure 27-2 shows the timing diagram. When released from the SLEEP mode, the Basic interval timer is activated on wake-up. It is increased from 00H until FFH. The count overflow is set to start normal operation.

Note :
 After SLEEP mode, at least one or more NOP instruction for data bus pre-charge time should be written.

```

LDM SSCR,#0FH
NOP           ;for data bus pre-charge time
NOP           ;for data bus pre-charge time
    
```

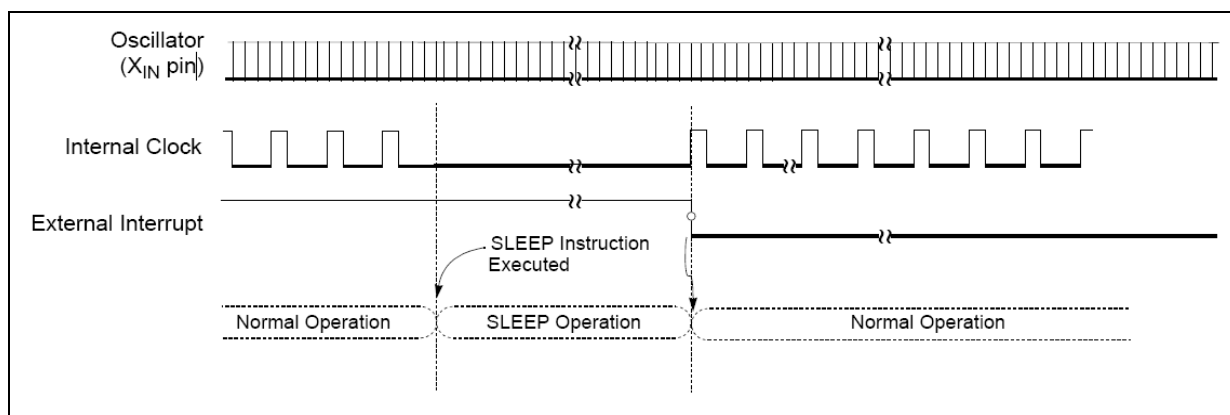

Figure 27-1 SLEEP Mode Release Timing by External Interrupt

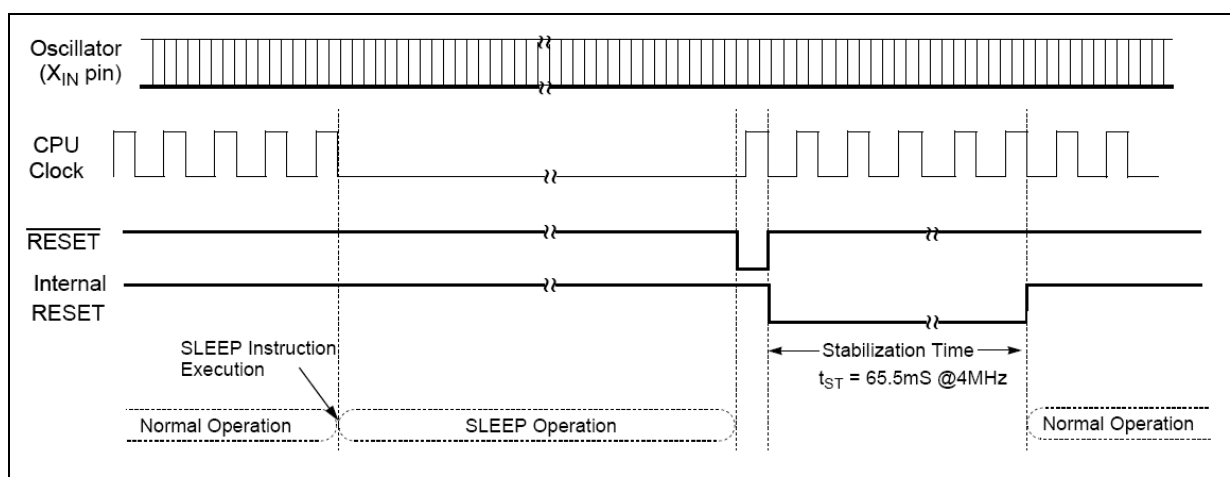

Figure 27-2 Timing of SLEEP Mode Release by Reset

27.2 Stop Mode

In the Stop mode, the system clock and the peripheral clocks are stopped, but the unselected clock source is keep running. See the "Table 27-1 Peripheral Operation During Power Saving Mode" for more information.

The states of the RAM, registers, and latches valid immediately before the system is put in the STOP state are all held.

The program counter stop the address of the instruction to be executed after the instruction "STOP" which starts the STOP operating mode.

Note :

The Stop mode is activated by execution of STOP instruction after setting the SSCR to "5AH". (This register should be written by byte operation. If this register is set by bit manipulation instruction, for example "set1" or "clr1" instruction, it may be undesired operation)

In the Stop mode of operation, V_{DD} can be reduced to minimize power consumption. Care must be taken, however, to ensure that V_{DD} is not reduced before the Stop mode is invoked, and that V_{DD} is restored to its normal operating level, before the Stop mode is terminated. The reset should not be activated before V_{DD} is restored to its normal operating level, and must be held active long enough to allow the oscillator to restart and stabilize.

Note :

After STOP instruction, at least two or more NOP instruction should be written.

Ex)

```
LDM CKCTLR,#0FH           ;more than 20ms
LDM SSCR,#5AH
STOP
NOP                       ;for stabilization time
NOP                       ;for stabilization time
```

In the STOP operation, the dissipation of the power associated with the oscillator and the internal hardware is lowered; however, the power dissipation associated with the pin interface (depending on the external circuitry and program) is not directly determined by the hardware operation of the STOP feature. This point should be little current flows when the input level is stable at the power voltage level (V_{DD}/V_{SS}); however, when the input level gets higher than the power voltage level (by approximately 0.3 to 0.5V), a current begins to flow. Therefore, if cutting off the output transistor at an I/O port puts the pin signal into the high-impedance state, a current flow across the ports input transistor, requiring to fix the level by pull-up or other means.

Release the STOP mode

The source for exit from STOP mode is hardware reset, external interrupt, Timer, Watch Timer, IIC Slave, SIO or UART. Reset re-defines all the Control registers but does not change the on-chip RAM(Be careful, If the code is compiled with RAM clear option, RAM is cleared after reset by ram clear routine. It is possible to disable the RAM clear option by option menu).

If I-flag = 1, the normal interrupt response takes place. If I-flag = 0, the chip will resume execution starting with the instruction following the STOP instruction. It will not vector to interrupt service routine.

(refer to Figure 27-3) When exit from Stop mode by external interrupt, enough oscillation stabilization time is required to normal operation. Figure 27-4 shows the timing diagram. When released from the Stop mode, the Basic interval timer is activated on wake-up. It is increased from 00H until FFH. The count overflow is set to start normal operation. Therefore, before STOP instruction, user must be set its relevant prescaler divide ratio to have long enough time (more than 20msec). This guarantees that oscillator has started and stabilized. By reset, exit from Stop mode is shown in Figure 27-5.

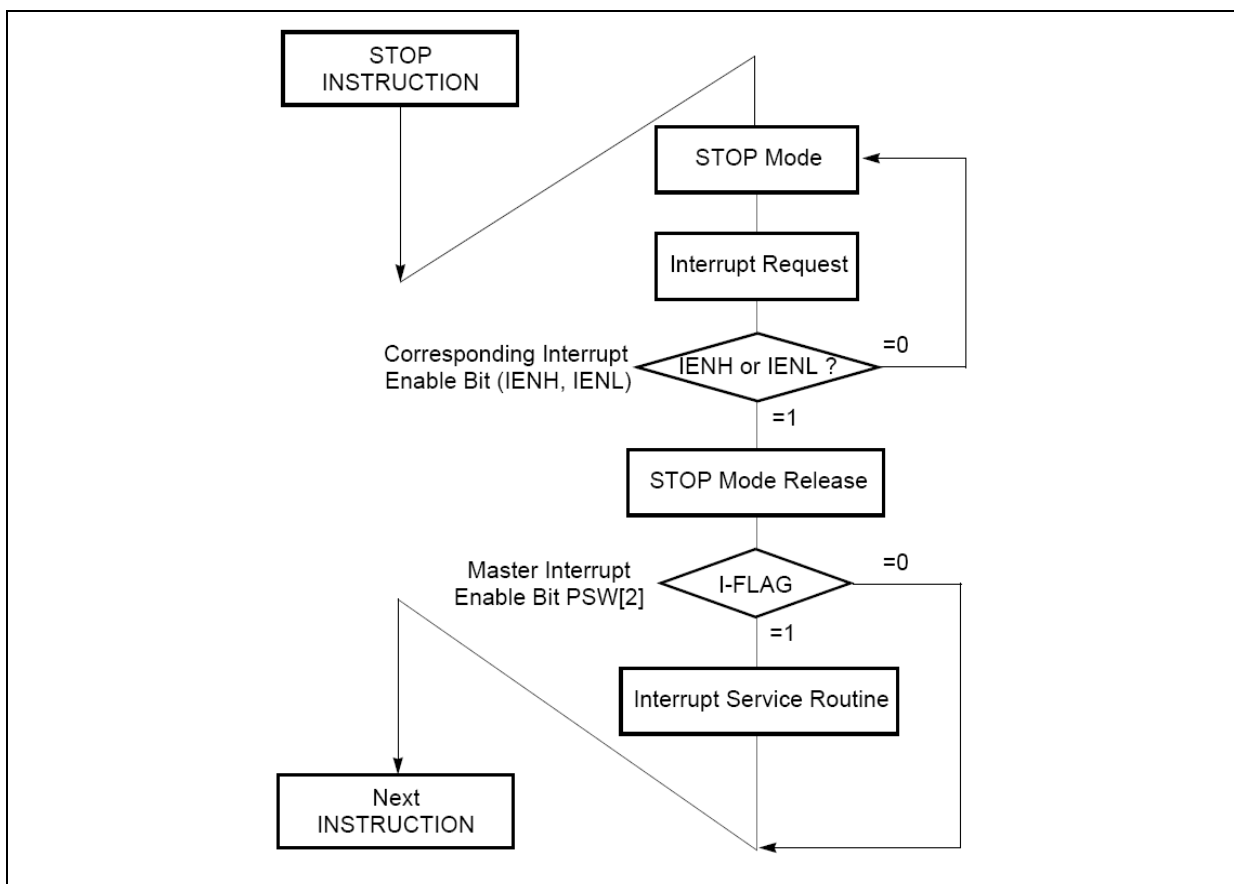

Figure 27-3 STOP Releasing Flow by Interrupts

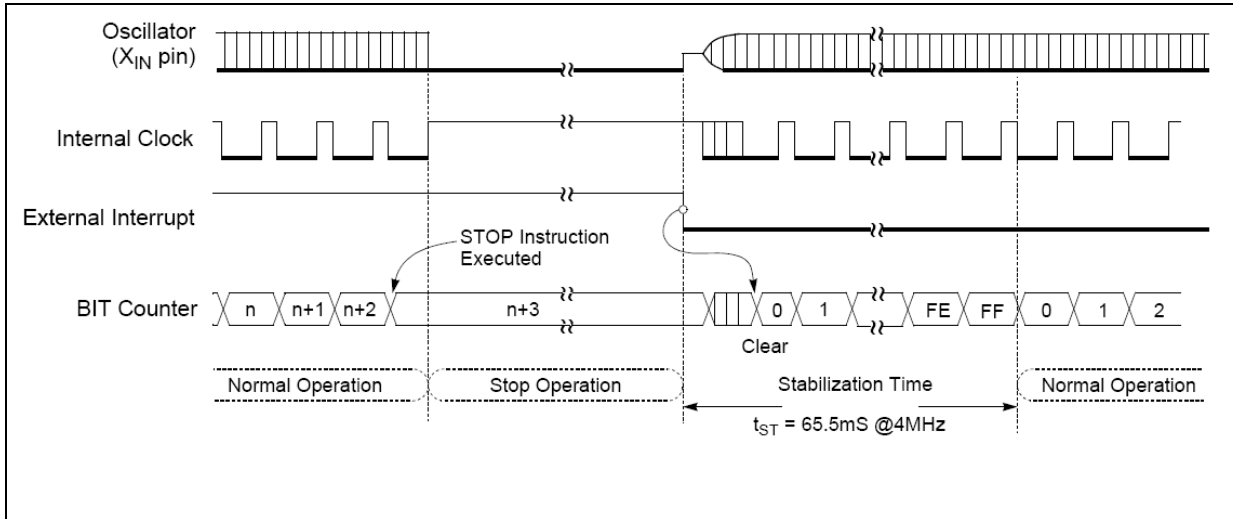

Figure 27-4 STOP Mode Release Timing by External Interrupt

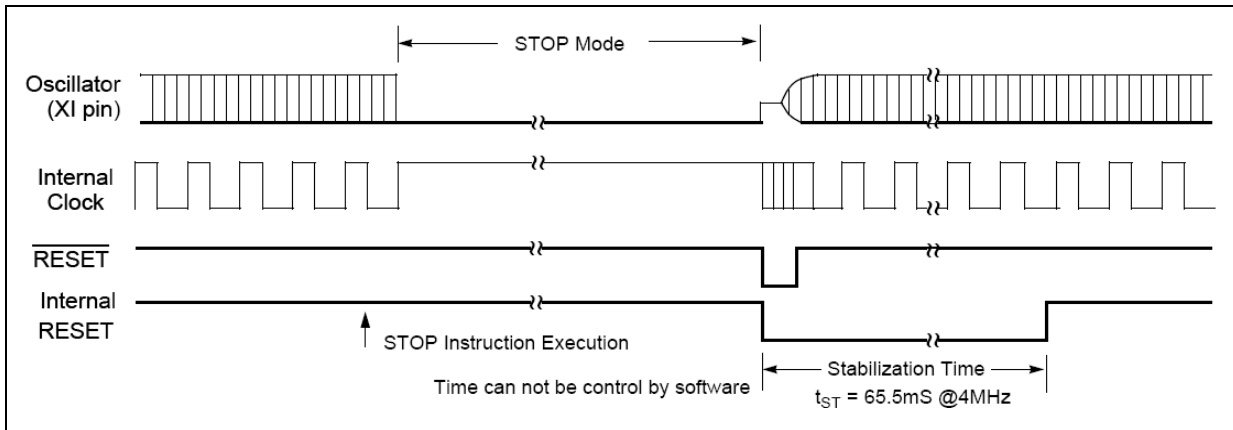

Figure 27-5 of STOP Mode Release by Reset

27.3 Sleep vs Stop

Peripheral	STOP in Main OSC	STOP in SUB OSC	SLEEP Mode
CPU	Stop		Stop
RAM	Retain		Retain
I/O Ports	Retain		Retain
Control Registers	Retain		Retain
Address Data Bus	Retain		Retain
ADC	Stop		Operate
Usart	Stop		Operate
SIO	Only operated with external clock		Operate
IIC Slave	Operate		Operate
Basic Interval Timer	Stop		Operate
Watchdog Timer	Stop		Operate
Watch Timer with System clock	Stop		Operate
Timer/Counter with System clock	Stop		Operate
Buzzer with System clock	Stop		Operate
Watch Timer with Sub clock	Operate	Stop	Operate
Timer/Counter with Sub clock	Operate	Stop	Operate
Buzzer with Sub clock	Operate	Stop	Operate
Main Oscillator	Stop	Oscillation	Oscillation
Sub Oscillator	Oscillation	Stop	Oscillation
Release Source	Reset, Timer(0,1,2,3) , Watch Timer(with Sub clock) , SIO, USART, IIC Slave , External Interrupt		Reset, All Interrupts

Table 27-1 Peripheral Operation During Power Saving Mode

Note: In the stop mode, system clock source is stopped. But unselected clock source is not stopped.
 For example, when main oscillator is selected as the system clock and the stop instruction is executed, main oscillator is stopped, but sub oscillator is not stopped. (assume that, both oscillator are working before stop instruction) In this case, the watch timer can be operated with sub oscillator.

27.4 Changing the stabilizing time

After reset or wake up from the stop/sleep mode, there is a stabilizing time to make sure the system oscillation is stabilized. Actually the stabilizing time is the basic interval timer's one cycle time.

So it is adjustable by changing the basic interval timer's clock division. (See chapter '15.BASIC INTERVAL TIMER' at page 122 to know how to change the basic interval timer's clock division.)

It is useful to reduce the power consumption in battery operation with stop/sleep mode. In the battery operation, reducing normal operation time is the key-point to reducing the power consumption.

Note that, it is not possible after reset. Because after reset, the control registers are initialized.

27.5 Minimizing Current Consumption

The Stop mode is designed to reduce power consumption. To minimize current drawn during Stop mode, the user should turnoff output drivers that are sourcing or sinking current, if it is practical.

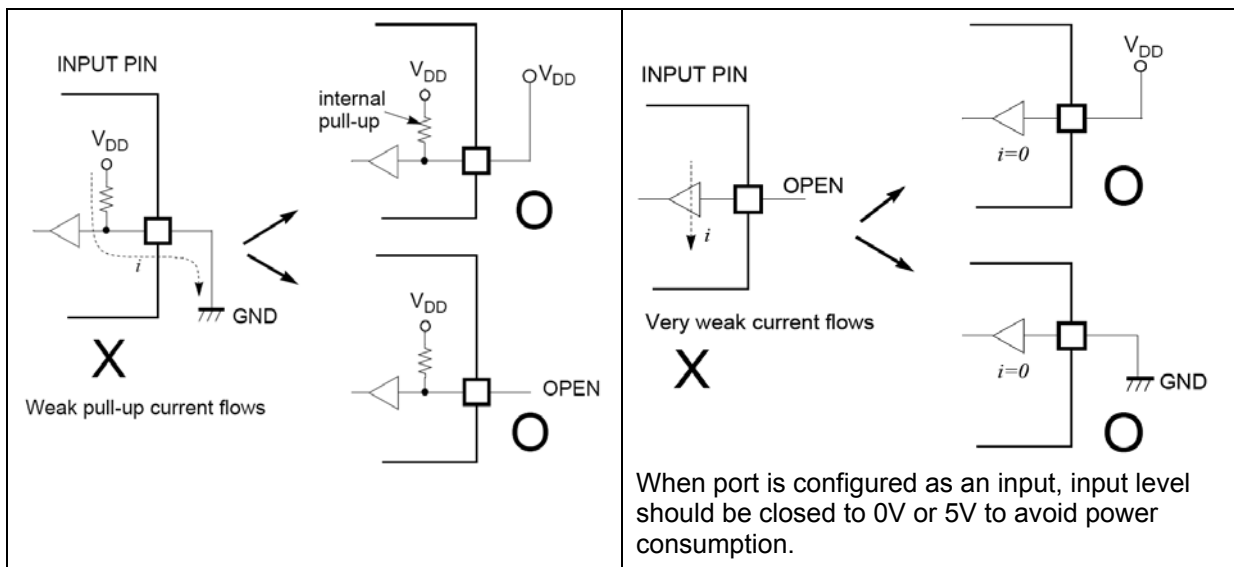

Figure 27-6 Application Example of Unused Input Port

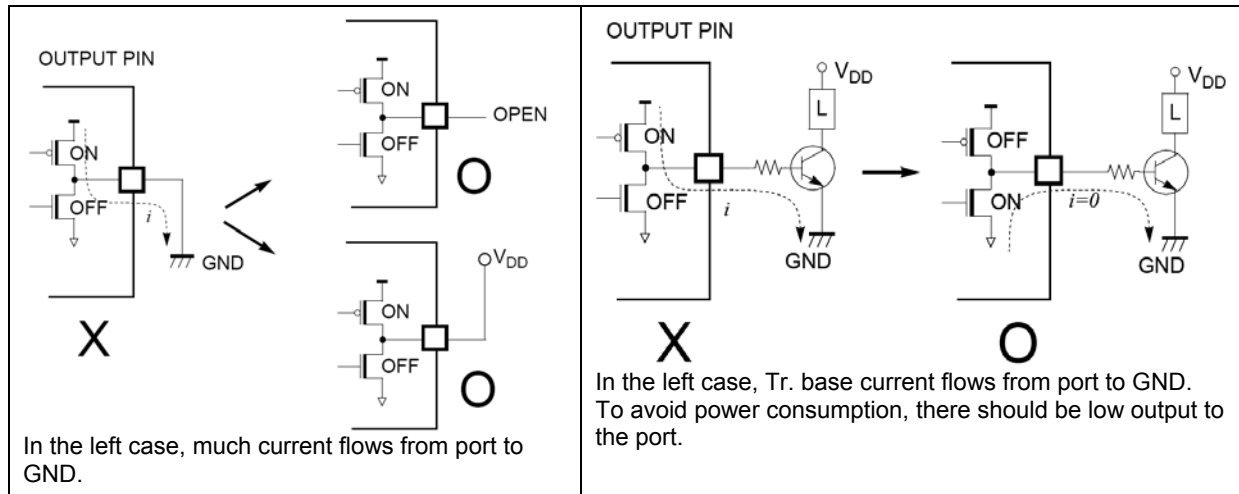

Figure 27-7 Application Example of Unused Output Port

In the STOP operation, the power dissipation associated with the oscillator and the internal hardware is lowered; however, the power dissipation associated with the pin interface (depending on the external circuitry and program) is not directly determined by the hardware operation of the STOP feature. This point should be little current flows when the input level is stable at the power voltage level (V_{DD}/V_{SS}); however, when the input level becomes higher than the power voltage level (by approximately 0.3V), a current begins to flow. Therefore, if cutting off the output transistor at an I/O port puts the pin signal into the high impedance state, a current flow across the ports input transistor, requiring it to fix the level by pull-up or other means.

It should be set properly in order that current flow through port doesn't exist.

First consider the port setting to input mode. Be sure that there is circuit. In input mode, the pin impedance viewing from external MCU is very high that the current doesn't flow. But input voltage level should be V_{SS} or V_{DD} . Be careful that if unspecified voltage, i.e. if uncertain voltage level (not V_{SS} or V_{DD}) is applied to input pin, there can be little current (max. 1mA at around 2V) flow.

If it is not appropriate to set as an input mode, then set to output mode considering there is no current flow. The port setting to High or Low is decided by considering its relationship with external circuit. For example, if there is external pull-up resistor then it is set to output mode, i.e. to High, and if there is external pull-down register, it is set to low.

28. EMULATOR

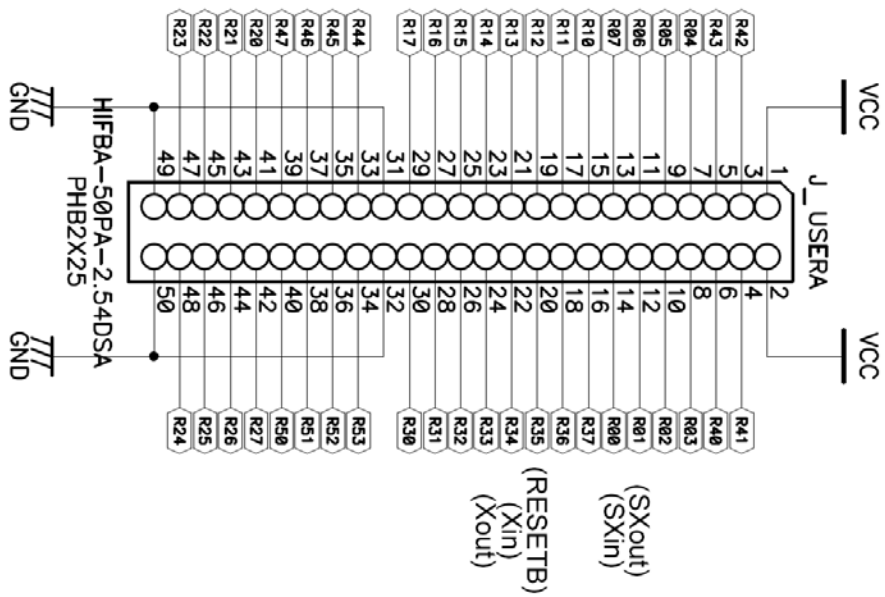
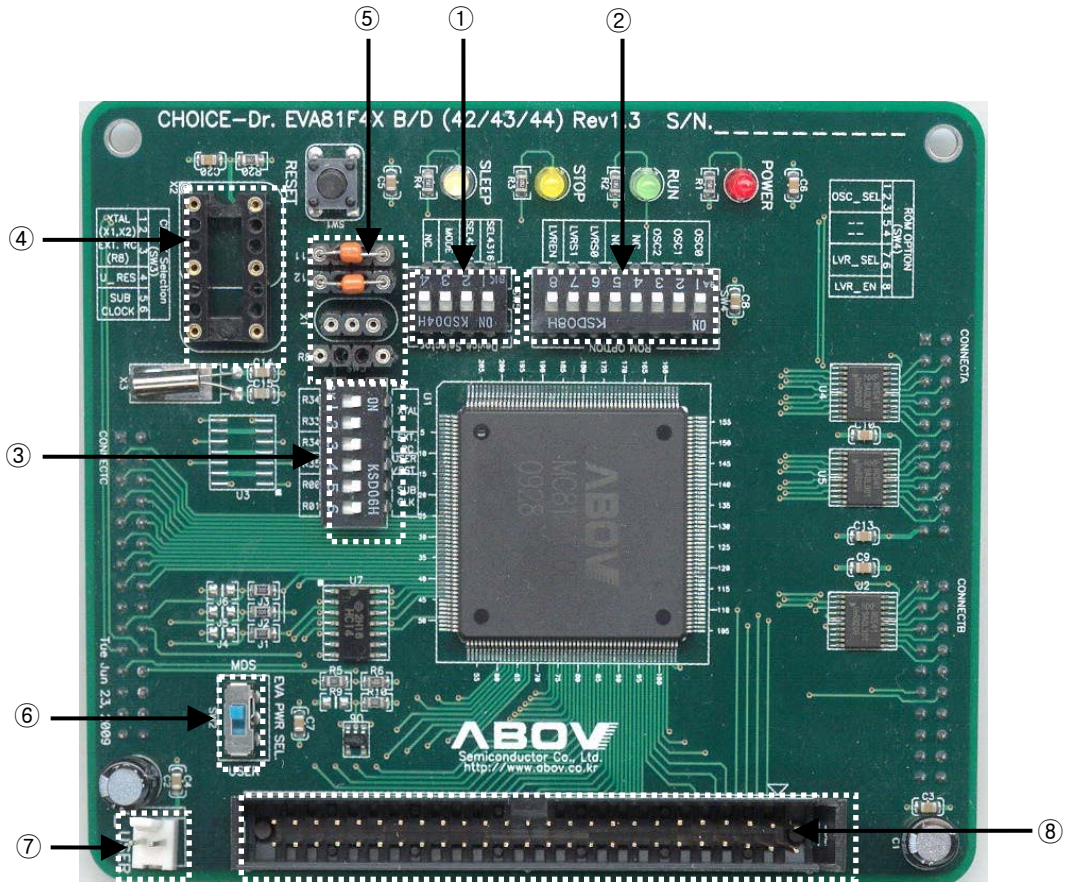

Mark	Name	Description
①	SW5.1 – SELL4x16	Those two switch are used to select the device mode SW5.1 :On & SW5.2:On : 4432 mode SW5.1 :Off & SW5.2:On : 4x16 mode SW5.1 :On & SW5.2:Off : 4204 mode
	SW5.2 – SELL4204	
	SW5.3 - MODE	It is used for developing emulator. So, user must turn it off always.
	SW5.4	Not Connected
②	SW4.1 – OSCS.0	Rom Option bit 0~2 : OSC Selection bits (On : 1, Off : 0) 000: External RC 001: Internal RC; 4MHz 010: Internal RC; 2MHz 011: Internal RC; 1MHz 100: Internal RC; 8MHz 101: Not available 110: Not available 111: Crystal/ceramic oscillator
	SW4.2 – OSCS.1	
	SW4.3 – OSCS.2	
	SW4.4	Not Connected
	SW4.5	Not Connected
	SW4.6 – LVRS.0	Rom Option bit 5~6 : Low Voltage Reset Level Selection bit (On : 1, Off : 0) 00: 2.4V 10: 3.0V 01: 2.7V 11: 4.0V
	SW4.7 – LVRS.1	
SW4.8 – LVREN	Rom Option bit 7 : Low Voltage Reset Enable bit On : (1) Disable (RESETB) Off : (0) Enable (R35)	
③	SW3.1 – R34	On : Connect the XTAL to R34/XIN pin Off : Disconnect
	SW3.2 – R33	On : Connect the XTAL to R33/XOUT pin Off : Disconnect
	SW3.3 – R34	On : Connect the EXT.RC to R34/XIN pin Off : Disconnect
	SW3.4 – R35	On : Connect the Reset to R35/Reset pin Off : Disconnect
	SW3.5 – R00	On : Connect the Sub-Clock to R00/SXIN pin Off : Disconnect
	SW3.6 – R01	On : Connect the Sub-Clock to R01/SXOUT pin Off : Disconnect

Mark	Name	Description
④	X2	A Oscillator socket
⑤	X1	A Crystal/Resonator socket
	C11	A capacitor socket for crystal
	C12	A capacitor socket for crystal
	R8	Register socket for External RC Oscillator
⑥	SW2 – EVA PWR SEL	<p>Eva.Board power source selection switch</p>  <p>Use MDS Power Use User's Power</p> <p>User's power source is supplied from the connector V_USER(⑦) which is described below.</p>
⑦	V_USER	A connector for power source which can be used for Eva.Board.
⑧	J_USERA	A connector for target system.

Note :

Only GND is connected between Eva.Board and the target system. VDD is not connected. So, the target system is required it's own power source.

29. IN SYSTEM PROGRAMMING

29.1 Getting Started

The In-System Programming (ISP) is an ability to program the code into the MCU while it is installed in a complete system.

USB_SIO_ISP uses both USB to communicate with PC and SIO to communicate with MCU. That is why we call it as 'USB_SIO_ISP'. In fact there are another ISP types. So remember that all MC81F4xxx series use 'USB_SIO_ISP'.

Here is a procedure to use ISP.

1. Power off the target system.

If you use the RESET/Vpp pin as an output mode, power on timing is very important. So you must read 'Entering ISP mode at power on time' and strictly obey the procedure.

2. Install the USB_SIO_ISP software. (It is required at only first time)

- 1) Download the ISP software from <http://www.abov.co.kr>
- 2) Unzip the downloaded file and connect the USB_SIO_ISP board.
- 3) Install the driver for USB_SIO_ISP. (There is a driver file in the zip file.)

3. Make sure the hardware condition is satisfied. And connect the ISP cable.

See '29.3 Hardware Conditions to Enter the ISP Mode' page 202,

4. Run the software and select a device.

All commands are enabled after select the device.

5. Power on the target system.

If you use the RESET/Vpp pin as an input mode, power on timing is not that important. But make sure the power is turned-on before execute the ISP commands.

6. Execute ISP commands as you want.

If you want to write a code into your MCU, it is recommendable to do following step.
'Load File' -> 'Auto'(while 'Auto Option Write' and 'Auto Show Option' options are enabled).

After finish an ISP command is executed, the MCU enters to normal operation mode automatically. So you can see the system is working right after the ISP command is finished. ('Auto' is assumed as one command')

In fact, it is possible to repeat the step-6 until the hardware condition is changed. But in case of RESET/Vpp pin is used as an output mode, do not repeat step-6. In that case, you must follow the procedure. See 'Entering ISP mode at power on time' for more information.

After you change the 'Rom Option', you must do power-off and power-on to reflect the changed 'Rom Option', even you can repeat the step-6 and see the changed code's operation without doing it. The MCU reads the 'Rom option' when only the 'power on reset time'.

29.2 Basic ISP S/W Information

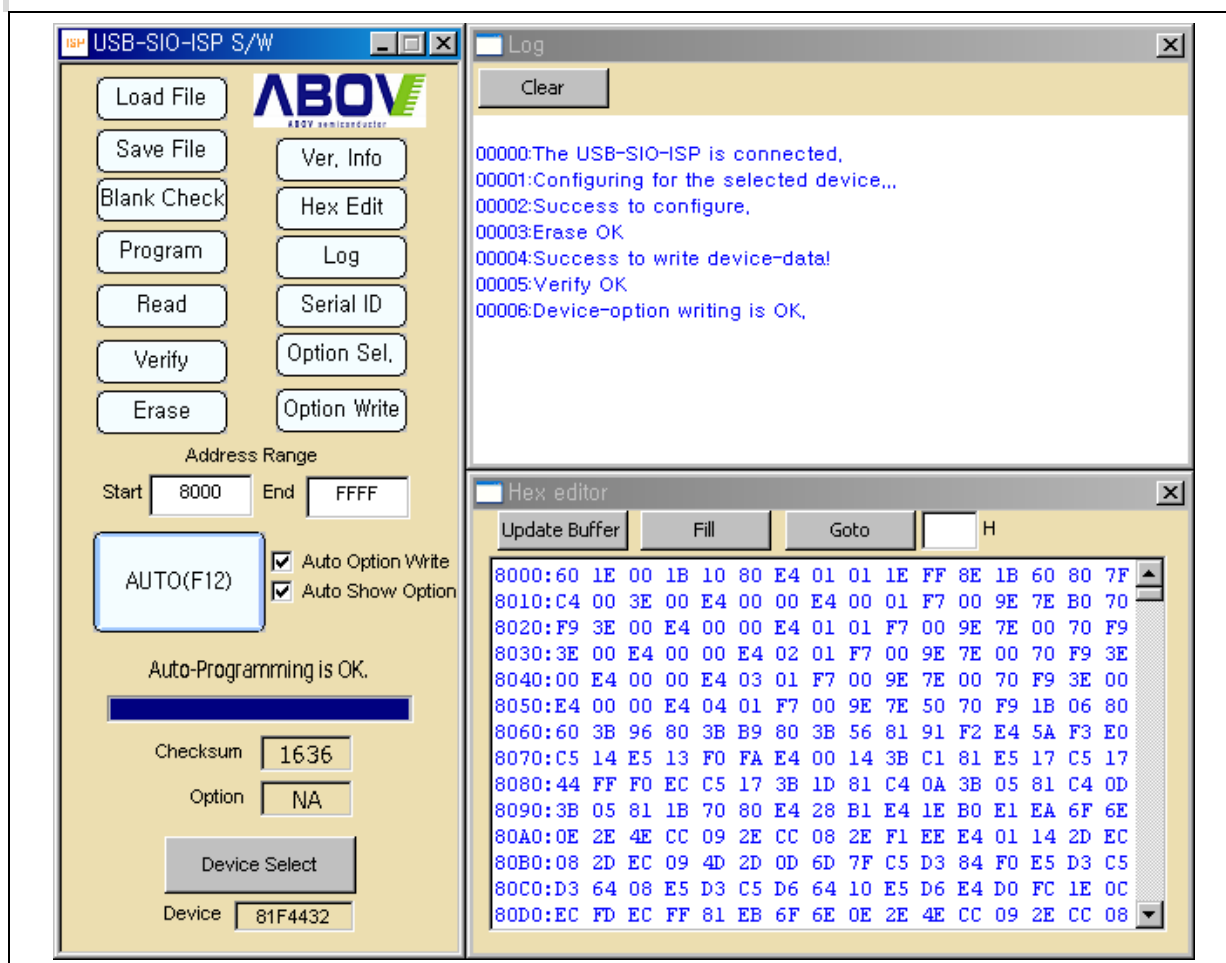

Figure 29-1 ISP Software

The Figure 29-1 is the USB_SIO_ISP software based on MS-Windows. This software supports only SIO_ISP type devices.

Function	Description
Load File	Load the data from the selected file storage into the memory buffer.
Save File	Save the current data in your memory buffer to a disk storage by using the Intel Motorola HEX format.
Blank Check	Verify whether or not a device is in an erased or unprogrammed state. Program This button enables you to place new data from the memory buffer into the target device.
Program	Write the current data into the MCU.
Read	Read the data in the target MCU into the buffer for examination. The checksum will be displayed on the checksum box.
Verify	Assures that data in the device matches data in the memory buffer. If your device is secured, a verification error is detected.

Erase	Erase the data in your target MCU before programming it.
Option Selection	Set the configuration data of target MCU. The security locking is set with this button.
Option Write	Program the configuration data of target MCU. The security locking is performed with this button.
AUTO	Following sequence is performed ; 1.Erase 2.Program 3.Verify 4.Option Write
Auto Option Write	Enable the option writing when the 'AUTO' sequence is executing.
Auto Show Option	Enable showing the option window when 'AUTO' button is pressed.
Ver. Info	It shows the version information.
Log	It shows/hides the log windows
Hex Edit	It shows/hides 'Hex editor'. In 'Hex editor' you can modify the currently loaded data.
Fill	Buffer Fill the selected area with a data.
Goto	Display the selected page.
Start _____	Starting address
End _____	End address
Checksum	Display the check sum(Hex decimal) after reading the target device.
Option	It shows currently selected option code in hexadecimal.
Device Select	It is used to select a target device.
Device	It shows currently selected device.

Note: MCU Configuration value is erased after erase operation. It must be configured to match with user target board. Otherwise, it is failed to enter ISP mode, or its operation is not desirable.

29.3 Hardware Conditions to Enter the ISP Mode

Anytime RESET/ Vpp pin goes +9V, the MCU entering an ISP mode except RESET/Vpp pin is output mode(See note1).

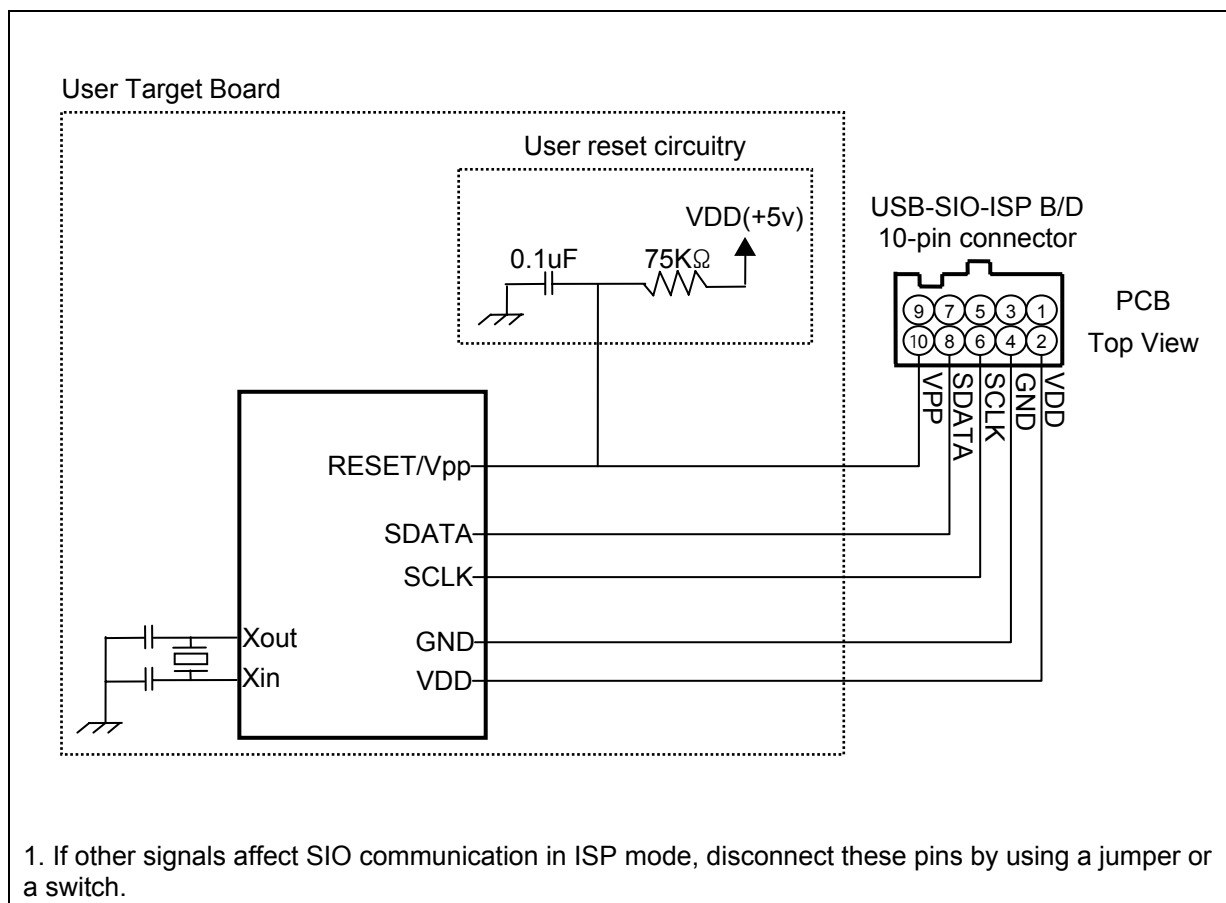

Figure 29-2 Hardware Conditions to Enter the ISP Mode

Note:

1) Using RESET/Vpp pin as an output mode is not recommended even it is possible. Anytime RESET/Vpp pin goes +9v, the MCU entering an ISP mode except RESET/Vpp pin is output mode. If it is output mode, +9v signal is clashing with the output voltage.

So if RESET/Vpp pin is used as an output mode, do not try to execute any ISP commands when MCU is in normal operation mode. It is allowable when only power on time. See 'Entering ISP mode at power on time' for more information.

2) There is a 10KΩ pull-down register at VPP pin in the ISP Board. That is why 75KΩ register is suggested for R/C reset circuit. So those two register makes a voltage divider circuit when ISP board is connected. So the VPP level can't go down to low level status if the register of reset circuit value is too small. Otherwise, if the register value is too large the capacitor value also changed and the reset circuit's characteristics also changed.

29.4 Entering ISP mode at power on time

Basically anytime +9v signal is forced to RESET/Vpp pin, the MCU is entering into ISP mode. But it makes trouble when the RESET/Vpp pin is output mode. Because the +9v signal is clashing with the port's output voltage.

But it is possible to enter the ISP mode at the power on time even RESET/Vpp pin is used as an output mode. There is an oscillator stabilizing time when power is turn on. While in the time RESET/Vpp pin is in input mode even it is used as an output mode in operation time.

A proper procedure is required to make sure that ISP board catch the oscillator stabilizing time to enter the ISP mode. See following procedure.

1. Power off the target system.
2. Configure the target system as ISP mode.
3. Attach a ISP B/D into the target system.
4. Run the ISP S/W
5. Select the target device.
6. Power on the target system.
7. Execute ISP commands as you want.

Note! Power on the target system after select the target device is essential. Because when target device is selected, ISP board is getting ready to catch the proper timing to rise the Vpp(+9v) signal.

29.5 USB-SIO-ISP Board

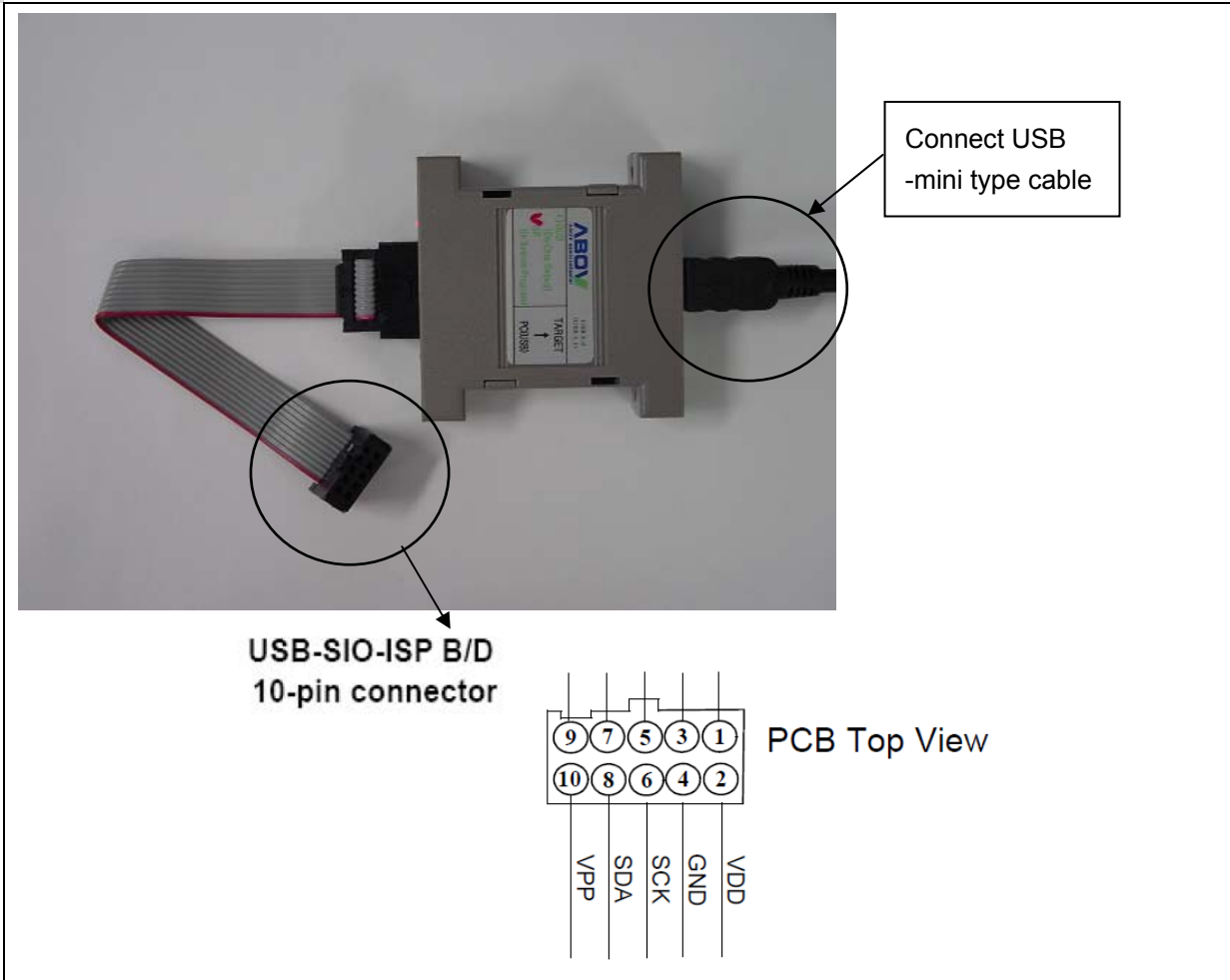
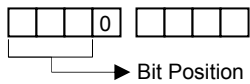
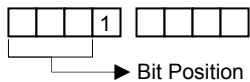

Figure 29-3 USB-SIO-ISP Board

30. INSTRUCTION SET

30.1 Terminology List

A	Accumulator
X	X - register
Y	Y - register
PSW	Program Status Word
#imm	8-bit Immediate data
dp	Direct Page Offset Address
!abs	Absolute Address
[]	Indirect expression
{ }	Register Indirect expression
{ }+	Register Indirect expression, after that, Register auto-increment
.bit	Bit Position
A.bit	Bit Position of Accumulator
dp.bit	Bit Position of Direct Page Memory
M.bit	Bit Position of Memory Data (000H~0FFFH)
rel	Relative Addressing Data
upage	U-page (0FF00H~0FFFFH) Offset Address
n	Table CALL Number (0~15)
+	Addition
x	Upper Nibble Expression in Opcode when it is even number (bit7~bit5, bit4=0) 
y	Upper Nibble Expression in Opcode when it is odd number (bit7~bit5, bit4=1) 
-	Subtraction
x	Multiplication
/	Division
()	Contents Expression
^	AND
∨	OR
⊕	Exclusive OR
~	NOT
←	Assignment / Transfer / Shift Left
→	Shift Right

↔	Exchange
=	Equal
≠	Not Equal

30.2 Instruction Map

LOW \ HIGH	0000 00	00001 01	00010 02	00011 03	00100 04	00101 05	00110 06	00111 07	01000 08	01001 09	01010 0A	01011 0B	01100 0C	01101 0D	01110 0E	01111 0F
000	-	SET1 dp.bit	BBS A.bit,rel	BBS dp.bit,rel	ADC #imm	ADC dp	ADC dp+X	ADC labs	ASL A	ASL dp	TCALL 0	SETA1 .bit	BIT dp	POP A	PUSH A	BRK
001	CLRC	"	"	"	SBC #imm	SBC dp	SBC dp+X	SBC labs	ROL A	ROL dp	TCALL 2	CLRA1 .bit	COM dp	POP X	PUSH X	BRA rel
010	CLRG	"	"	"	CMP #imm	CMP dp	CMP dp+X	CMP labs	LSR A	LSR dp	TCALL 4	NOT1 M.bit	TST dp	POP Y	PUSH Y	PCALL Upage
011	DI	"	"	"	OR #imm	OR dp	OR dp+X	OR labs	ROR A	ROR dp	TCALL 6	OR1 OR1B	CMPX dp	POP PSW	PUSH PSW	RET
100	CLRV	"	"	"	AND #imm	AND dp	AND dp+X	AND labs	INC A	INC dp	TCALL 8	AND1 AND1B	CMPY dp	CBNE dp+X	TXSP	INC X
101	SETC	"	"	"	EOR #imm	EOR dp	EOR dp+X	EOR labs	DEC A	DEC dp	TCALL 10	EOR1 EOR1B	DBNE dp	XMA dp+X	TSPX	DEC X
110	SETG	"	"	"	LDA #imm	LDA dp	LDA dp+X	LDA labs	TXA	LDY dp	TCALL 12	LDC LDCB	LDX dp	LDX dp+Y	XCN	DAS (N/A)
111	EI	"	"	"	LDM dp,#imm	STA dp	STA dp+X	STA labs	TAX	STY dp	TCALL 14	STC M.bit	STX dp	STX dp+Y	XAX	STOP

LOW \ HIGH	10000 10	10001 11	10010 12	10011 13	10100 14	10101 15	10110 16	10111 17	11000 18	11001 19	11010 1A	11011 1B	11100 1C	11101 1D	11110 1E	11111 1F
000	BPL rel	CLR1 dp.bit	BBC A.bit,rel	BBC dp.bit,rel	ADC {X}	ADC !labs+Y	ADC [dp+X]	ADC [dp]+Y	ASL labs	ASL dp+X	TCALL 1	JMP labs	BIT labs	ADDW dp	LDX #imm	JMP [labs]
001	BVC rel	"	"	"	SBC {X}	SBC !labs+Y	SBC [dp+X]	SBC [dp]+Y	ROL labs	ROL dp+X	TCALL 3	CALL labs	TEST labs	SUBW dp	LDY #imm	JMP [dp]
010	BCC rel	"	"	"	CMP {X}	CMP !labs+Y	CMP [dp+X]	CMP [dp]+Y	LSR labs	LSR dp+X	TCALL 5	MUL	TCLR1 labs	CMPW dp	CMPX #imm	CALL [dp]
011	BNE rel	"	"	"	OR {X}	OR !labs+Y	OR [dp+X]	OR [dp]+Y	ROR labs	ROR dp+X	TCALL 7	DBNE Y	CMPX labs	LDYA dp	CMPY #imm	RETI
100	BMI rel	"	"	"	AND {X}	AND !labs+Y	AND [dp+X]	AND [dp]+Y	INC labs	INC dp+X	TCALL 9	DIV	CMPY labs	INCW dp	INC Y	TAY
101	BVS rel	"	"	"	EOR {X}	EOR !labs+Y	EOR [dp+X]	EOR [dp]+Y	DEC labs	DEC dp+X	TCALL 11	XMA {X}	XMA dp	DECW dp	DEC Y	TYA
110	BCS rel	"	"	"	LDA {X}	LDA !labs+Y	LDA [dp+X]	LDA [dp]+Y	LDY labs	LDY dp+X	TCALL 13	LDA {X}+	LDX labs	STYA dp	XAY	DAA (N/A)
111	BEQ rel	"	"	"	STA {X}	STA !labs+Y	STA [dp+X]	STA [dp]+Y	STY labs	STY dp+X	TCALL 15	STA {X}+	STX labs	CBNE dp	XYX	NOP

30.3 Instruction Set

Arithmetic / Logic

NO.	MNEMONIC	OP CODE	BYTE NO	CYCLE NO	OPERATION	FLAG NVGBHIZC
1	ADC #imm	04	2	2	Add with carry. $A \leftarrow (A) + (M) + C$	NV--H-ZC
2	ADC dp	05	2	3		
3	ADC dp + X	06	2	4		
4	ADC !abs	07	3	4		
5	ADC !abs + Y	15	3	5		
6	ADC [dp + X]	16	2	6		
7	ADC [dp] + Y	17	2	6		
8	ADC { X }	14	1	3		
9	AND #imm	84	2	2	Logical AND $A \leftarrow (A) \wedge (M)$	N----Z-
10	AND dp	85	2	3		
11	AND dp + X	86	2	4		
12	AND !abs	87	3	4		
13	AND !abs + Y	95	3	5		
14	AND [dp + X]	96	2	6		
15	AND [dp] + Y	97	2	6		
16	AND { X }	94	1	3		
17	ASL A	08	1	2	Arithmetic shift left	N----ZC
18	ASL dp	09	2	4		
19	ASL dp + X	19	2	5		
20	ASL !abs	18	3	5		
21	CMP #imm	44	2	2		Compare accumulator contents with memory contents $(A) - (M)$
22	CMP dp	45	2	3		
23	CMP dp + X	46	2	4		
24	CMP !abs	47	3	4		
25	CMP !abs + Y	55	3	5		
26	CMP [dp + X]	56	2	6		

NO.	MNEMONIC	OP CODE	BYTE NO	CYCLE NO	OPERATION	FLAG NVGBHIZC
27	CMP [dp] + Y	57	2	6		
28	CMP { X }	54	1	3		
29	CMPX #imm	5E	2	2	Compare X contents with memory contents (X) - (M)	N----ZC
30	CMPX dp	6C	2	3		
31	CMPX !abs	7C	3	4		
32	CMPY #imm	7E	2	2	Compare Y contents with memory contents (Y) - (M)	N----ZC
33	CMPY dp	8C	2	3		
34	CMPY !abs	9C	3	4		
35	COM dp	2C	2	4	1's Complement : (dp) \leftarrow \sim (dp)	N----Z-
36	DAA	-	-	-	Unsupported	-
37	DAS	-	-	-	Unsupported	-
38	DEC A	A8	1	2	Decrement $M \leftarrow (M) - 1$	N----Z-
39	DEC dp	A9	2	4		
40	DEC dp + X	B9	2	5		
41	DEC !abs	B8	3	5		
42	DEC X	AF	1	2		
43	DEC Y	BE	1	2		
44	DIV	9B	1	12	Divide : YA/X Q:A, R:Y	NV--H-Z-
45	EOR #imm	A4	2	2	Exclusive OR $A \leftarrow (A) \oplus (M)$	N----Z-
46	EOR dp	A5	2	3		
47	EOR dp + X	A6	2	4		
48	EOR !abs	A7	3	4		
49	EOR !abs + Y	B5	3	5		
50	EOR [dp + X]	B6	2	6		
51	EOR [dp] + Y	B7	2	6		
52	EOR { X }	B4	1	3		
53	INC A	88	1	2	Increment $M \leftarrow (M) + 1$	N----Z-
54	INC dp	89	2	4		

NO.	MNEMONIC	OP CODE	BYTE NO	CYCLE NO	OPERATION	FLAG NVGBHIZC
55	INC dp + X	99	2	5		
56	INC !abs	98	3	5		
57	INC X	8F	1	2		
58	INC Y	9E	1	2		
59	LSR A	48	1	2	Arithmetic shift left	N----ZC
60	LSR dp	49	2	4		
61	LSR dp + X	59	2	5		
62	LSR !abs	58	3	5		
63	MUL	5B	1	9	Multiply : $YA \leftarrow Y \times A$	N----Z-
64	OR #imm	64	2	2	Logical OR $A \leftarrow (A) \vee (M)$	N----Z-
65	OR dp	65	2	3		
66	OR dp + X	66	2	4		
67	OR !abs	67	3	4		
68	OR !abs + Y	75	3	5		
69	OR [dp + X]	76	2	6		
70	OR [dp] + Y	77	2	6		
71	OR { X }	74	1	3		
72	ROL A	28	1	2	Rotate left through carry	N----ZC
73	ROL dp	29	2	4		
74	ROL dp + X	39	2	5		
75	ROL !abs	38	3	5		
76	ROR A	68	1	2	Rotate right through carry	N----ZC
77	ROR dp	69	2	4		
78	ROR dp + X	79	2	5		
79	ROR !abs	78	3	5		
80	SBC #imm	24	2	2	Subtract with carry $A \leftarrow (A) - (M) - \sim(C)$	NV--HZC
81	SBC dp	25	2	3		
82	SBC dp + X	26	2	4		

NO.	MNEMONIC	OP CODE	BYTE NO	CYCLE NO	OPERATION	FLAG NVGBHIZC
83	SBC labs	27	3	4		
84	SBC labs + Y	35	3	5		
85	SBC [dp + X]	36	2	6		
86	SBC [dp] + Y	37	2	6		
87	SBC { X }	34	1	3		
88	TST dp	4C	2	3	Test memory contents for negative or zero (dp) – 00H	N----Z-
89	XCN	CE	1	5	Exchange nibbles within the accumulator A7~A4 ↔ A3~A0	N----Z-

Register / Memory Operation

NO.	MNEMONIC	OP CODE	BYTE NO	CYCLE NO	OPERATION	FLAG NVGBHIZC
1	LDA #imm	C4	2	2	Load accumulator $A \leftarrow (M)$	N----Z-
2	LDA dp	C5	2	3		
3	LDA dp + X	C6	2	4		
4	LDA labs	C7	3	4		
5	LDA labs + Y	D5	3	5		
6	LDA [dp + X]	D6	2	6		
7	LDA [dp] + Y	D7	2	6		
8	LDA { X }	D4	1	3		
9	LDA { X }+	DB	1	4	X-register auto-increment : $A \leftarrow (M), X \leftarrow X + 1$	
10	LDM dp, #imm	E4	3	5	Load memory with immediate data : $(M) \leftarrow imm$	-----
11	LDX #imm	1E	2	2	Load X-register $X \leftarrow (M)$	N----Z-
12	LDX dp	CC	2	3		
13	LDX dp + Y	CD	2	4		
14	LDX labs	DC	3	4		
15	LDY #imm	3E	2	2	Load Y-register $Y \leftarrow (M)$	N----Z-
16	LDY dp	C9	2	3		
17	LDY dp + Y	D9	2	4		
18	LDY labs	D8	3	4		
19	STA dp	E5	2	4	Store accumulator contents in memory $(M) \leftarrow A$	-----
20	STA dp + X	E6	2	5		
21	STA labs	E7	3	5		
22	STA labs + Y	F5	3	6		
23	STA [dp + X]	F6	2	7		
24	STA [dp] + Y	F7	2	7		
25	STA { X }	F4	1	4		

NO.	MNEMONIC	OP CODE	BYTE NO	CYCLE NO	OPERATION	FLAG NVGBHIZC
26	STA {X}+	FB	1	4	X-register auto-increment : $(M) \leftarrow A, X \leftarrow X + 1$	
27	STX dp	EC	2	4	Store X-register contents in memory $(M) \leftarrow X$	-----
28	STX dp + Y	ED	2	5		
29	STX labs	FC	3	5		
30	STY dp	E9	2	4	Store Y-register contents in memory $(M) \leftarrow Y$	-----
31	STY dp + X	F9	2	5		
32	STY labs	F8	3	5		
33	TAX	E8	1	2	Transfer accumulator contents to X-register : $X \leftarrow A$	N----Z-
34	TAY	9F	1	2	Transfer accumulator contents to Y-register : $Y \leftarrow A$	N----Z-
35	TSPX	AE	1	2	Transfer stack-pointer contents to X-register : $X \leftarrow sp$	N----Z-
36	TXA	C8	1	2	Transfer X-register contents to accumulator : $A \leftarrow X$	N----Z-
37	TXSP	8E	1	2	Transfer X-register contents to stack-pointer : $sp \leftarrow X$	N----Z-
38	TYA	BF	1	2	Transfer Y-register contents to accumulator : $A \leftarrow Y$	N----Z-
39	XAX	EE	1	4	Exchange X-register contents with accumulator : $X \leftrightarrow A$	-----
40	XAY	DE	1	4	Exchange Y-register contents with accumulator : $Y \leftrightarrow A$	-----
41	XMA dp	BC	2	5	Exchange memory contents with accumulator : $(M) \leftrightarrow A$	N----Z-
42	XMA dp + X	AD	2	6		
43	XMA {X}	BB	1	5		
44	XYX	FE	1	4	Exchange X-register contents with Y-register : $X \leftrightarrow Y$	-----

16 BIT manipulation

NO.	MNEMONIC	OP CODE	BYTE NO	CYCLE NO	OPERATION	FLAG NVGBHIZC
1	ADDW dp	1D	2	5	16-bits add without carry $YA \leftarrow (YA) + (dp + 1)(dp)$	NV--H-ZC
2	CMPW dp	5D	2	4	Compare YA contents with memory pair contents : $(YA) - (dp + 1)(dp)$	N----ZC
3	DECW dp	BD	2	6	Decrement memory pair $(dp + 1)(dp) \leftarrow (dp + 1)(dp) - 1$	N----Z-
4	INCW dp	9D	2	6	Increment memory pair $(dp + 1)(dp) \leftarrow (dp + 1)(dp) + 1$	N----Z-
5	LDYA dp	7D	2	5	Load YA $YA \leftarrow (dp + 1)(dp)$	N----Z-
6	STYA dp	DD	2	5	Store YA $(dp + 1)(dp) \leftarrow YA$	-----
7	SUBW dp	3D	2	5	16-bits subtract without carry $YA \leftarrow (YA) - (dp + 1)(dp)$	NV--H-ZC

BIT manipulation

NO.	MNEMONIC	OP CODE	BYTE NO	CYCLE NO	OPERATION	FLAG NVGBHIZC
1	AND1 M.bit	8B	3	4	Bit AND C-flag : $C \leftarrow (C) \wedge (M.bit)$	-----C
2	AND1B M.bit	8B	3	4	Bit AND C-flag and NOT : $C \leftarrow (C) \wedge \sim(M.bit)$	-----C
3	BIT dp	0C	2	4	Bit test A with memory : $Z \leftarrow (A) \wedge (M), N \leftarrow (M7), V \leftarrow (M6)$	MM----Z-
4	BIT !abs	1C	3	5		
5	CLR1 dp.bit	y1	2	4	Clear bit : $(M.bit) \leftarrow "0"$	-----
6	CLRA1 A.bit	2B	2	2	Clear A bit : $(A.bit) \leftarrow "0"$	-----
7	CLRC	20	1	2	Clear C-flag : $C \leftarrow "0"$	-----0
8	CLRG	40	1	2	Clear G-flag : $G \leftarrow "0"$	--0----
9	CLRV	80	1	2	Clear V-flag : $V \leftarrow "0"$	-0--0---
10	EOR1 M.bit	AB	3	5	Bit exclusive-OR C-flag : $C \leftarrow (C) \oplus (M.bit)$	-----C
11	EOR1B M.bit	AB	3	5	Bit exclusive-OR C-flag and NOT : $C \leftarrow (C) \oplus \sim(M.bit)$	-----C
12	LDC M.bit	CB	3	4	Load C-flag : $C \leftarrow (M.bit)$	-----C
13	LDCB M.bit	CB	3	4	Load C-flag with NOT : $C \leftarrow \sim(M.bit)$	-----C
14	NOT1 M.bit	4B	3	5	Bit complement : $(M.bit) \leftarrow \sim(M.bit)$	-----
15	OR1 M.bit	6B	3	5	Bit OR C-flag : $C \leftarrow C \vee (M.bit)$	-----C
16	OR1B M.bit	6B	3	5	Bit OR C-flag and NOT : $C \leftarrow C \vee \sim(M.bit)$	-----C
17	SET1 dp.bit	x1	2	4	Set bit : $(M.bit) \leftarrow "1"$	-----
18	SETA1 A.bit	0B	2	2	Set A bit : $(A.bit) \leftarrow "1"$	-----
19	SETC	A0	1	2	Set C-flag : $C \leftarrow "1"$	-----1
20	SETG	C0	1	2	Set G-flag : $G \leftarrow "1"$	--1----
21	STC M.bit	EB	3	6	Store C-flag : $(M.bit) \leftarrow C$	-----
22	TCLR1 !abs	5C	3	6	Test and clear bits with A : $A - (M), (M) \leftarrow (M) \wedge \sim(A)$	N----Z-
23	TSET1 !abs	3C	3	6	Test and set bits with A : $A - (M), (M) \leftarrow (M) \vee (A)$	N----Z-

Branch / Jump

NO.	MNEMONIC	OP CODE	BYTE NO	CYCLE NO	OPERATION	FLAG NVGBHIZC
1	BBC A.bit, rel	y2	2	4/6	Branch if bit clear : If (bit) = 0, then pc ← (pc) + rel	-----
2	BBC dp.bit, rel	y3	3	5/7		
3	BBS A.bit, rel	x2	2	4/6	Branch if bit set : If (bit) = 1, then pc ← (pc) + rel	-----
4	BBS dp.bit, rel	x3	3	5/7		
5	BCC rel	50	2	2/4	Branch if carry bit clear : If (C) = 0, then pc ← (pc) + rel	-----
6	BCS rel	D0	2	2/4	Branch if carry bit set : If (C) = 1, then pc ← (pc) + rel	-----
7	BEQ rel	F0	2	2/4	Branch if equal : If (Z) = 1, then pc ← (pc) + rel	-----
8	BMI rel	90	2	2/4	Branch if minus : If (N) = 1, then pc ← (pc) + rel	-----
9	BNE rel	70	2	2/4	Branch if not equal : If (Z) = 0, then pc ← (pc) + rel	-----
10	BPL rel	10	2	2/4	Branch if plus : If (N) = 0, then pc ← (pc) + rel	-----
11	BRA rel	2F	2	4	Branch always : pc ← (pc) + rel	-----
12	BVC rel	30	2	2/4	Branch if overflow bit clear : If (V) = 0, then pc ← (pc) + rel	-----
13	BVS rel	B0	2	2/4	Branch if overflow bit set : If (V) = 1, then pc ← (pc) + rel	-----
14	CALL !abs	3B	3	8	Subroutine call M(sp) ← (pcH), sp ← sp - 1, M(sp) ← (pcL), sp ← sp - 1, If !abs, pc ← abs ; if [dp], pcL ← (dp), pcH ← (dp + 1)	-----
15	CALL [dp]	5F	2	8		
16	CBNE dp, rel	FD	3	5/7	Compare and branch if not equal : if (A) ≠ (M), then pc ← (pc) + rel	-----
17	CBNE dp+X, rel	8D	3	6/8		
18	DBNE dp, rel	AC	3	5/7	Decrement and branch if not equal : if (M) ≠ 0, then pc ← (pc) + rel	-----
19	DBNE Y, rel	7B	2	4/6		
20	JMP !abs	1B	3	3	Unconditional jump : pc ← jump address	-----
21	JMP [!abs]	1F	3	5		
22	JMP [dp]	3F	2	4		

NO.	MNEMONIC	OP CODE	BYTE NO	CYCLE NO	OPERATION	FLAG NVGBHIZC
23	PCALL upage	4F	2	6	U-page call $M(sp) \leftarrow (pcH), sp \leftarrow sp - 1,$ $M(sp) \leftarrow (pcL), sp \leftarrow sp - 1,$ $pcL \leftarrow (upage), pcH \leftarrow "0FFH"$	-----
24	TCALL n	nA	1	8	Table call $M(sp) \leftarrow (pcH), sp \leftarrow sp - 1,$ $M(sp) \leftarrow (pcL), sp \leftarrow sp - 1,$ $pcL \leftarrow (Table\ vector\ L), pcH \leftarrow (Table\ vector\ H)$	-----

Control Operation / Etc

NO.	MNEMONIC	OP CODE	BYTE NO	CYCLE NO	OPERATION	FLAG NVGBHIZC
1	BRK	0F	1	8	Software interrupt : $B \leftarrow "1",$ $M(sp) \leftarrow (pcH), sp \leftarrow sp - 1,$ $M(sp) \leftarrow (pcL), sp \leftarrow sp - 1,$ $M(sp) \leftarrow (PSW), sp \leftarrow sp - 1,$ $pcL \leftarrow (0FFDEH), pcH \leftarrow (0FFDFH)$	---1-0--
2	DI	60	1	3	Disable interrupt : $I \leftarrow "0"$	----0--
3	EI	E0	1	3	Enable interrupt : $I \leftarrow "1"$	----1--
4	NOP	FF	1	2	No operation	-----
5	POP A	0D	1	4	$sp \leftarrow sp + 1, A \leftarrow M(sp)$ $sp \leftarrow sp + 1, X \leftarrow M(sp)$ $sp \leftarrow sp + 1, Y \leftarrow M(sp)$ $sp \leftarrow sp + 1, PSW \leftarrow M(sp)$	-----
6	POP X	2D	1	4		-----
7	POP Y	4D	1	4		-----
8	POP PSW	6D	1	4		restored
9	PUSH A	0E	1	4	$M(sp) \leftarrow A, sp \leftarrow sp - 1$ $M(sp) \leftarrow X, sp \leftarrow sp - 1$ $M(sp) \leftarrow Y, sp \leftarrow sp - 1$ $M(sp) \leftarrow PSW, sp \leftarrow sp - 1$	-----
10	PUSH X	2E	1	4		-----
11	PUSH Y	4E	1	4		-----
12	PUSH PSW	6E	1	4		-----
13	RET	6F	1	5	Return from subroutine $sp \leftarrow sp + 1, pcL \leftarrow M(sp),$ $sp \leftarrow sp + 1, pcH \leftarrow M(sp)$	-----
14	RETI	7F	1	6	Return from interrupt $sp \leftarrow sp + 1, PSW \leftarrow M(sp),$ $sp \leftarrow sp + 1, pcL \leftarrow M(sp),$ $sp \leftarrow sp + 1, pcH \leftarrow M(sp)$	restored
15	STOP	EF	1	3	Stop mode (halt CPU, stop oscillator)	-----

