

ABOV SEMICONDUCTOR Co., Ltd.  
8-BIT MICROCONTROLLERS

# MC95FG0128A

User's Manual (Ver. 3.1)



## REVISION HISTORY

VERSION	COMMENT	DATE
3.1	Revised the font of this document	(Dec 14, 2022)
3.0	Update Device Nomenclature. (Chapter 1.3)	(Jul 15, 2021)
2.9	Modified Internal RC oscillator spec. (Chapter 7.7, 7.8) Update Development Tools. (Chapter 1.4) Add Device Nomenclature.	(Aug 02, 2018)
2.8	Add "direct input port Bit test and branch" instruction warning	(April 30, 2015)
2.7	Change Configure Option naming.	(Jul 04, 2014)
2.6	Correct Pin description (LPF).	(Jan 16, 2012)
2.5	Correct PSR address.	(Dec 21, 2011)
2.4	Appendix D (Instructions on how to use the input port) added.	(Nov 24, 2011)
2.3	Add DC Characteristics	(Aug 17, 2011)
2.2	Add PWM description	(Jun 07, 2011)
2.1	Add Package type	(Apr 26, 2011)
2.0	Correct A/D Converter Characteristics	(Mar 03, 2011)
1.9	Correct Interrupt register, Port selection register name	(Feb 10, 2011)
1.8	AC description modification	(Jan 18, 2011)
1.7	Timer register description modification	(Jan 07, 2011)
1.6	TxD R register increment range modification	(Nov 23, 2010)
1.5	Update 11.1.5 register description for clock generator	(Oct 30, 2010)
1.4	Update gang 4 → gang 8	(Apr 09, 2010)
1.3	fix Figure 10.5 Multi interrupt(add 'SETB EA') and update example Correct Figure 11-17 (timer 2, 3, 4 block diagram)	(Feb 04, 2010)
1.2	update Figure 11-45 ADC Block Diagram.	(Jan 18, 2010)
1.1	update 11.7.8.2 transmit flag and interrupt, 11.7.12 USTAT register	(Jan 15, 2010)
1.0	update special Pin description add LPF circuit, change open drain port description	(Jan 11, 2010)

Published by AE Team

©2021 ABOV Semiconductor Co.,Ltd. All rights reserved.

---

Additional information of this manual may be served by ABOV Semiconductor offices in Korea or Distributors.

ABOV Semiconductor reserves the right to make changes to any information here in at any time without notice.

The information, diagrams and other data in this manual are correct and reliable.

However, ABOV Semiconductor is in no way responsible for any violations of patents or other rights of the third party generated by the use of this manual.

# Table of Contents

REVISION HISTORY .....	2
Table of Contents .....	4
List of Figures.....	7
MC95FG0128A .....	10
1. Overview .....	10
1.1 Description .....	10
1.2 Features.....	10
1.3 Ordering Information .....	12
1.4 Development Tools .....	13
2. Block Diagram .....	18
3. Pin Assignmnet .....	21
4. Package Diagram.....	26
5. Pin Description .....	31
6. Port Structures .....	35
6.1 General Purpose I/O Port .....	35
6.2 External Interrupt I/O Port.....	36
7. Electrical Characteristics.....	37
7.1 Absolute Maximum Ratings .....	37
7.2 Recommended Operating Conditions .....	37
7.3 A/D Converter Characteristics .....	38
7.4 Voltage Dropout Converter Characteristics .....	38
7.5 Power-On Reset Characteristics .....	39
7.6 Brown Out Detector Characteristics .....	39
7.7 Internal RC Oscillator Characteristics.....	39
7.8 Ring-Oscillator Characteristics .....	40
7.9 PLL Characteristics.....	40
7.10 DC Characteristics.....	41
7.11 AC Characteristics .....	43
7.12 SPI Characteristics .....	44
7.13 Typical Characteristics.....	45
8. Memory .....	46
8.1 Program Memory .....	46
8.2 Data Memory .....	48
8.3 EEPROM Data Memory and XSRAM.....	50
8.4 SFR Map.....	51
9. I/O Ports .....	55
9.1 I/O Ports.....	55
9.2 Port Register .....	55
9.3 Px Port .....	58
10. Interrupt Controller .....	60
10.1 Overview .....	60
10.2 External Interrupt .....	60
10.3 Block Diagram .....	62
10.4 Interrupt Vector Table .....	63

10.5	Interrupt Sequence .....	63
10.6	Effective Timing after Controlling Interrupt bit .....	65
10.7	Multi Interrupt.....	66
10.8	Interrupt Enable Accept Timing .....	67
10.9	Interrupt Service Routine Address.....	67
10.10	Saving/Restore General-Purpose Registers .....	67
10.11	Interrupt Timing.....	68
10.12	Interrupt Register Overview .....	68
10.13	Interrupt Register Description .....	70
11.	Peripheral Hardware .....	75
11.1	Clock Generator.....	75
11.2	BIT .....	79
11.3	WDT.....	81
11.4	WT .....	84
11.5	Timer/PWM.....	87
11.6	Buzzer Driver .....	110
11.7	USART.....	112
11.8	SPI .....	130
11.9	I <sup>2</sup> C .....	135
11.10	12-Bit A/D Converter.....	152
11.11	CALCULATOR_AI .....	157
12.	Power Down Operation .....	161
12.1	Overview .....	161
12.2	Peripheral Operation in IDLE/STOP Mode.....	161
12.3	IDLE mode .....	162
12.4	STOP mode .....	162
12.5	Release Operation of STOP1, 2 Mode .....	164
13.	RESET .....	166
13.1	Overview.....	166
13.2	Reset source.....	166
13.3	Block Diagram .....	166
13.4	RESET Noise Canceller .....	167
13.5	Power ON RESET .....	167
13.6	External RESETB Input .....	170
13.7	Brown Out Detector Processor.....	171
14.	On-chip Debug System.....	174
14.1	Overview .....	174
14.2	Two-pin external interface .....	175
15.	Memory Programming.....	179
15.1	Overview .....	179
15.2	Flash and EEPROM Control and status register .....	179
15.3	Memory map.....	183
15.4	Serial In-System Program Mode .....	186
15.5	Parallel Mode.....	193
15.6	Mode entrance method of ISP and byte-parallel mode .....	196
15.7	Security.....	197

---

16. Configure option .....	198
16.1 Configure option Control Register .....	198
17. APPENDIX .....	199

# List of Figures

Figure 1.1 Device Nomenclature .....	12
Figure 1.2 Debugger and Pin description .....	13
Figure 1.3 OCD Interface Circuit .....	14
Figure 1.4 E-PGM+ component and connector .....	15
Figure 1.5 PGMplusLC Writer .....	16
Figure 1.6 E-PGM+ Gang4/6 Programmer.....	17
Figure 2.1 MC95FG0128A block diagram .....	18
Figure 2.2 MC95FG8128A block diagram .....	19
Figure 2.3 MC95FG6128A block diagram .....	20
Figure 3.1 MC95FG0128A 100 Pin LQFP assignment .....	21
Figure 3.2 MC95FG0128A 80 Pin LQFP assignment .....	22
Figure 4.1 100 pin LQFP package.....	26
Figure 4.2 80 pin LQFP package.....	27
Figure 4.3 80 pin MQFP package.....	28
Figure 4.4 64 pin LQFP package.....	29
Figure 4.5 64 pin LQFP14 package.....	30
Figure 6.1 General Purpose I/O Port.....	35
Figure 6.2 General Purpose I/O Port.....	36
Figure 7.1 AC Timing.....	43
Figure 7.2 SPI Timing .....	44
Figure 8.1 Program memory.....	47
Figure 8.2 Data memory map .....	48
Figure 8.3 Lower 128 bytes RAM .....	49
Figure 8.4 XDATA memory area .....	50
Figure 10.1 External Interrupt Description.....	61
Figure 10.2 Block Diagram of Interrupt.....	62
Figure 10.3 Interrupt Sequence Flow .....	64
Figure 10.4 Interrupt Enable Register effective Timing .....	65
Figure 10.5 Execution of Multi Interrupt.....	66
Figure 10.6 Interrupt Response Timing Diagram .....	67
Figure 10.7 Correspondence between vector Table address and the entry address of ISR .	67
Figure 10.8 Saving/Restore Process Diagram & Sample Source .....	67
Figure 10.9 Timing chart of Interrupt Acceptance and Interrupt Return Instruction .....	68
Figure 11.1 Clock Generator Block Diagram.....	75
Figure 11.2 BIT Block Diagram .....	79
Figure 11.3 WDT Block Diagram.....	81
Figure 11.4 WDT Interrupt Timing Waveform .....	83
Figure 11.5 Watch Timer Block Diagram.....	84
Figure 11.6 8 Bit Timer/Event Counter2, 3 Block Diagram .....	88
Figure 11.7 Timer/Event Counter0, 1 Example .....	89
Figure 11.8 Operation Example of Timer/Event Counter0, 1 .....	89

Figure 11.9 16 Bit Timer/Event Counter0, 1 Block Diagram .....	90
Figure 11.10 8-bit Capture Mode for Timer0, 1 .....	91
Figure 11.11 Input Capture Mode Operation of Timer 0, 1 .....	92
Figure 11.12 Express Timer Overflow in Capture Mode .....	92
Figure 11.13 16-bit Capture Mode of Timer 0, 1 .....	93
Figure 11.14 PWM Mode.....	94
Figure 11.15 Example of PWM at 4MHz .....	95
Figure 11.16 Example of Changing the Period in Absolute Duty Cycle at 4Mhz .....	95
Figure 11.17 Timerx 16-bit Mode Block Diagram.....	101
Figure 11.18 16-bit Capture Mode of Timer x .....	102
Figure 11.19 PWM Mode.....	103
Figure 11.20 Example of PWM at 8MHz .....	104
Figure 11.21 Buzzer Driver Block Diagram .....	110
Figure 11.22 USART Block Diagram.....	113
Figure 11.23 Clock Generation Block Diagram .....	114
Figure 11.24 Synchronous Mode XCKn Timing .....	115
Figure 11.25 frame format .....	116
Figure 11.26 Start Bit Sampling.....	120
Figure 11.27 Sampling of Data and Parity Bit .....	120
Figure 11.28 Stop Bit Sampling and Next Start Bit Sampling .....	121
Figure 11.29 SPI Clock Formats when UCPHA=0 .....	122
Figure 11.30 SPI Clock Formats when UCPHA=1 .....	123
Figure 11.31 SPI Block Diagram .....	130
Figure 11.32 SPI Transmit/Receive Timing Diagram at CPHA = 0 .....	132
Figure 11.33 SPI Transmit/Receive Timing Diagram at CPHA = 1 .....	132
Figure 11.34 I <sup>2</sup> C Block Diagram .....	135
Figure 11.35 Bit Transfer on the I <sup>2</sup> C-Bus .....	136
Figure 11.36 START and STOP Condition .....	136
Figure 11.37 Data Transfer on the I <sup>2</sup> C-Bus.....	137
Figure 11.38 Acknowledge on the I <sup>2</sup> C-Bus.....	137
Figure 11.39 Clock Synchronization during Arbitration Procedure .....	138
Figure 11.40 Arbitration Procedure of Two Masters.....	138
Figure 11.41 Formats and States in the Master Transmitter Mode.....	141
Figure 11.42 Formats and States in the Master Receiver Mode.....	143
Figure 11.43 Formats and States in the Slave Transmitter Mode.....	145
Figure 11.44 Formats and States in the Slave Receiver Mode.....	147
Figure 11.45 ADC Block Diagram .....	152
Figure 11.46 A/D Analog Input Pin Connecting Capacitor .....	153
Figure 11.47 A/D Power(AVDD) Pin Connecting Capacitor.....	153
Figure 11.48 ADC Operation for Align bit.....	153
Figure 11.49 Converter Operation Flow .....	154
Figure 11.50 Calculator Block Diagram.....	157
Figure 12.1 IDLE Mode Release Timing by External Interrupt.....	162



Figure 12.2 IDLE Mode Release Timing by /RESET .....	162
Figure 12.3 STOP Mode Release Timing by External Interrupt .....	163
Figure 12.4 STOP Mode Release Timing by /RESET .....	163
Figure 12.5 STOP1, 2 Mode Release Flow .....	164
Figure 13.1 RESET Block Diagram .....	166
Figure 13.2 Reset noise canceller time diagram .....	167
Figure 13.3 Fast VDD rising time .....	167
Figure 13.4 Internal RESET Release Timing On Power-Up .....	168
Figure 13.5 Configuration timing when Power-on .....	168
Figure 13.6 Boot Process Wave Form .....	169
Figure 13.7 Timing Diagram after RESET .....	170
Figure 13.8 Oscillator generating waveform example .....	170
Figure 13.9 Block Diagram of BOD .....	171
Figure 13.10 Internal Reset at the power fail situation .....	171
Figure 13.11 Configuration timing when BOD RESET .....	172
Figure 14.1 Block Diagram of On-chip Debug System .....	175
Figure 14.2 10-bit transmission packet .....	176
Figure 14.3 Data transfer on the twin bus .....	176
Figure 14.4 Bit transfer on the serial bus .....	177
Figure 14.5 Start and stop condition .....	177
Figure 14.6 Acknowledge on the serial bus .....	177
Figure 14.7 Clock synchronization during wait procedure .....	178
Figure 14.8 Connection of transmission .....	178
Figure 15.1 Flash Memory Map .....	183
Figure 15.2 Address configuration of Flash memory .....	184
Figure 15.3 Data EEPROM memory map .....	184
Figure 15.4 Address configuration of data EEPROM .....	185
Figure 15.5 The sequence of page program and erase of Flash memory .....	186
Figure 15.6 The sequence of bulk erase of Flash memory .....	187
Figure 15.7 Pin diagram for parallel programming .....	193
Figure 15.8 Parallel Byte Read Timing of Program Memory .....	194
Figure 15.9 Parallel Byte Write Timing of Program Memory .....	195
Figure 15.10 ISP mode .....	196
Figure 15.11 Byte-parallel mode .....	196

# MC95FG0128A

## CMOS SINGLE-CHIP 8-BIT MICROCONTROLLER WITH 12-BIT A/D CONVERTER

### 1. Overview

#### 1.1 Description

The MC95FG0128A is an advanced CMOS 8-bit microcontroller with 128K bytes of FLASH. This is powerful microcontroller which provides a highly flexible and cost effective solution to many embedded control applications. This provides the following features : 128K bytes of FLASH, 256 bytes of SRAM, 4K bytes of Data EEPROM, 8K bytes of XRAM general purpose I/O, 8/16-bit timer/counter, watchdog timer, watch timer, SPI, USART, I<sup>2</sup>C, Calculator, on-chip POR and BOD, 12-bit A/D converter, buzzer driving port, 16-bit PWM output, on-chip oscillator and clock circuitry. The MC95FG0128A also supports power saving modes to reduce power consumption.

Device Name	FLASH	EEPROM	XRAM	SRAM	ADC	Package
MC95FG0128A	128K bytes	4K bytes	8K bytes	256 bytes	15 channel	100LQFP 80LQFP 80MQFP 64LQFP 64LQPF14

#### 1.2 Features

- **CPU**
  - 8 Bit CISC Core (8051 Compatible, 2 clock per cycle)
- **128K Bytes On-chip FLASH**
  - Endurance : 10,000 times
  - Retention : 10 years
- **4K Bytes Data EEPROM**
  - Endurance : 100,000 times
  - Retention : 10 years
- **256 Bytes SRAM**
- **8K Bytes XRAM**
- **General Purpose I/O**
  - 86 Ports (P0[7:0], P1[7:0], P2[7:0], P3[7:0], P4[7:0], P5[7:0], P6[7:0], P7[7:0], P8[7:0], P9[7:0], PA[5:0]) : 100 Pin
  - 66 Ports (P0[7:0], P1[7:0], P2[7:0], P3[7:0], P4[7:0], P5[7:0], P6[5:0], P7[7:0], P8[1:0]) : 80 Pin
  - 52 Ports (P0[7:0], P1[7:0], P2[7:0], P3[7:0], P4[7:0], P5[7:0], P6[3:0]) : 64 Pin
  - Support TTL compatible PAD (P3[7:0], SPI0, USART1)
- **Basic Interval Timer**
- **Timer / Counter 6Ch**
  - 8Bitx2ch(16Bitx1ch) + 16Bitx4ch
- **1Ch 10-bit PWM (using Timer1)**
- **4Ch 16-bit PWM (using Timer2,3,4,5)**

- **Watch Dog Timer**
- **Watch Timer**
- **2 SPI**
- **4 USART** (4th usart can use only 100pin)
- **I<sup>2</sup>C**
- **Buzzer Driving Port**
- **Calculator**
  - Multiplier mode : 16bits x 16bits
  - Divider mode : 32bits / 16bits
- **12 Bit A/D Converter**
  - 15 Input channels
- **Interrupt Sources**
  - External (8)
  - Pin Change Interrupt (P0, P7) (2)
  - USART (8)
  - SPI (2)
  - Timer (6)
  - I<sup>2</sup>C (1)
  - ADC (1)
  - WDT (1)
  - WT (1)
  - BIT (1)
  - EEPROM (1)
- **On-Chip RC-Oscillator**
  - 8MHz OSC ( ±1.5%@25°C)
- **On-Chip WDT-Oscillator**
  - 8MHz OSC ( ±50%@-40~+85°C)
- **On-Chip PLL**
  - 1.38MHz ~ 20.18MHz (with 32.768KHz)
- **Power On Reset**
  - 1.4V
- **Programmable Brown-Out Detector**
  - 1.6V / 2.5V / 3.6V / 4.2V
- **Minimum Instruction Execution Time**
  - 200ns (@10MHz, NOP Instruction)
- **Power down mode**
  - IDLE, STOP1, STOP2 mode
- **Sub-Active mode**
  - System used external 32.768KHz crystal
- **Operating Frequency**
  - 1MHz ~ 10MHz (crystal oscillator)
  - 1, 2, 4, 8MHz (internal RC oscillator)
  - 1.38MHz ~ 20.18MHz (PLL)
- **Operating Voltage**
  - 2.7V ~ 5.5V (@ 1~20.18MHz)
- **Operating Temperature : -40 ~ +85°C**
- **Package Type**
  - 100 LQFP
  - 80 LQFP
  - 80 MQFP
  - 64 LQFP
  - 64 LQFP14
  - Pb free package

### 1.3 Ordering Information

**Table 1-1 Ordering Information of MC95FG0128A**

Device name	ROM size	SRAM size	XRAM size	EEPROM size	Package
MC95FG0128AL	128 Kbytes FLASH	256 bytes	8 Kbytes	4 Kbytes	100 LQFP
MC95FG8128AL					80 LQFP
MC95FG8128AQ					80 MQFP
MC95FG6128AL					64 LQFP
MC95FG6128ALBN					64 LQFP
MC95FG6128AL14					64 LQFP14

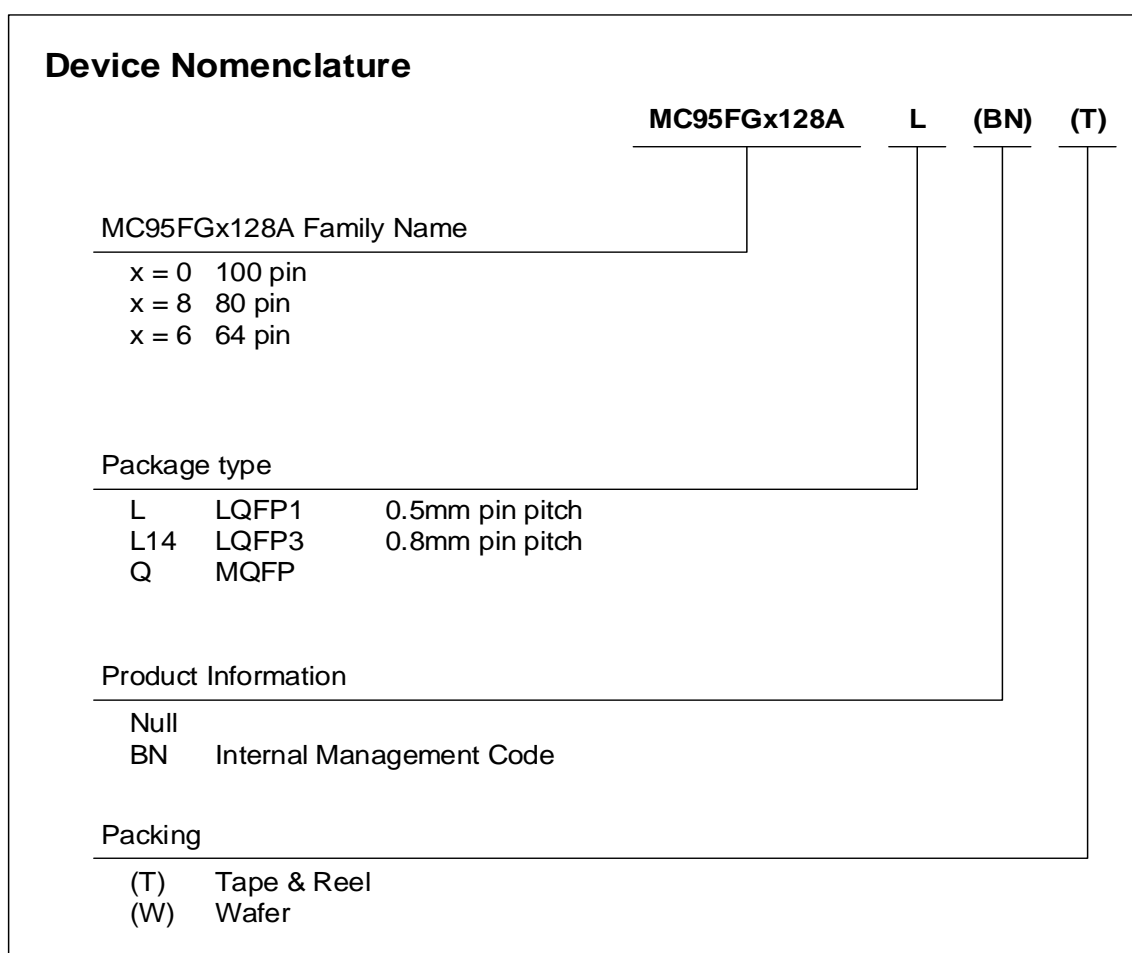

**Figure 1.1 Device Nomenclature**

## 1.4 Development Tools

### 1.4.1 Compiler

ABOV Semiconductor does not provide compiler. It is recommended that you consult a compiler provider.

The MC95FG0128A core is Mentor 8051. Device ROM size of standard 8051 is smaller than 64KB. Developer can use all kinds of third party's standard 8051 compiler. But MC95FG0128A has 128KB code ROM area and uses memory banking scheme for this extended ROM. So user should use the proper compiler which can support the memory space over 64KB ROM address area.

### 1.4.2 OCD emulator and debugger

The OCD (On Chip Debug) emulator supports ABOV Semiconductor's 8051 series MCU emulation. The OCD interface uses two-wire connection between PC and MCU which is attached to user's system. The OCD can read or change the value of MCU internal memory and I/O peripherals. And the OCD also controls MCU internal debugging logic, it means OCD controls emulation, step run, monitoring, etc.

The OCD Debugger program works on Microsoft-Windows NT, 2000, XP, Vista (32-bit), 7, 8, 10 operating system.

If you want to see more details, please refer OCD debugger manual. You can download debugger S/W and manual from our web-site.

On-Board programming :

The program memory of MC95FG308 is FLASH Memory Type. This flash is accessed by serial data format. There are four pins (DSCL, DSDA, VDD, and VSS) for programming/reading the flash. The MC95FG308 needs only four signal lines including VDD and VSS pins for programming FLASH with serial protocol. Therefore the on-board programming is possible if the programming signal lines are considered when the PCB of application board is designed.

Connection:

- SCLK (MC95FG0128A DSCL pin)
- SDAT (MC95FG0128A DSDA pin)

OCD connector diagram: Connect OCD and user system

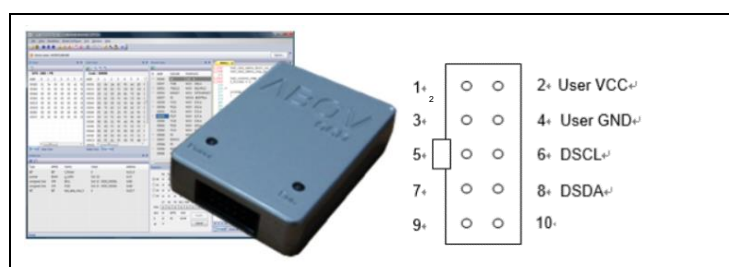

**Figure 1.2 Debugger and Pin description**

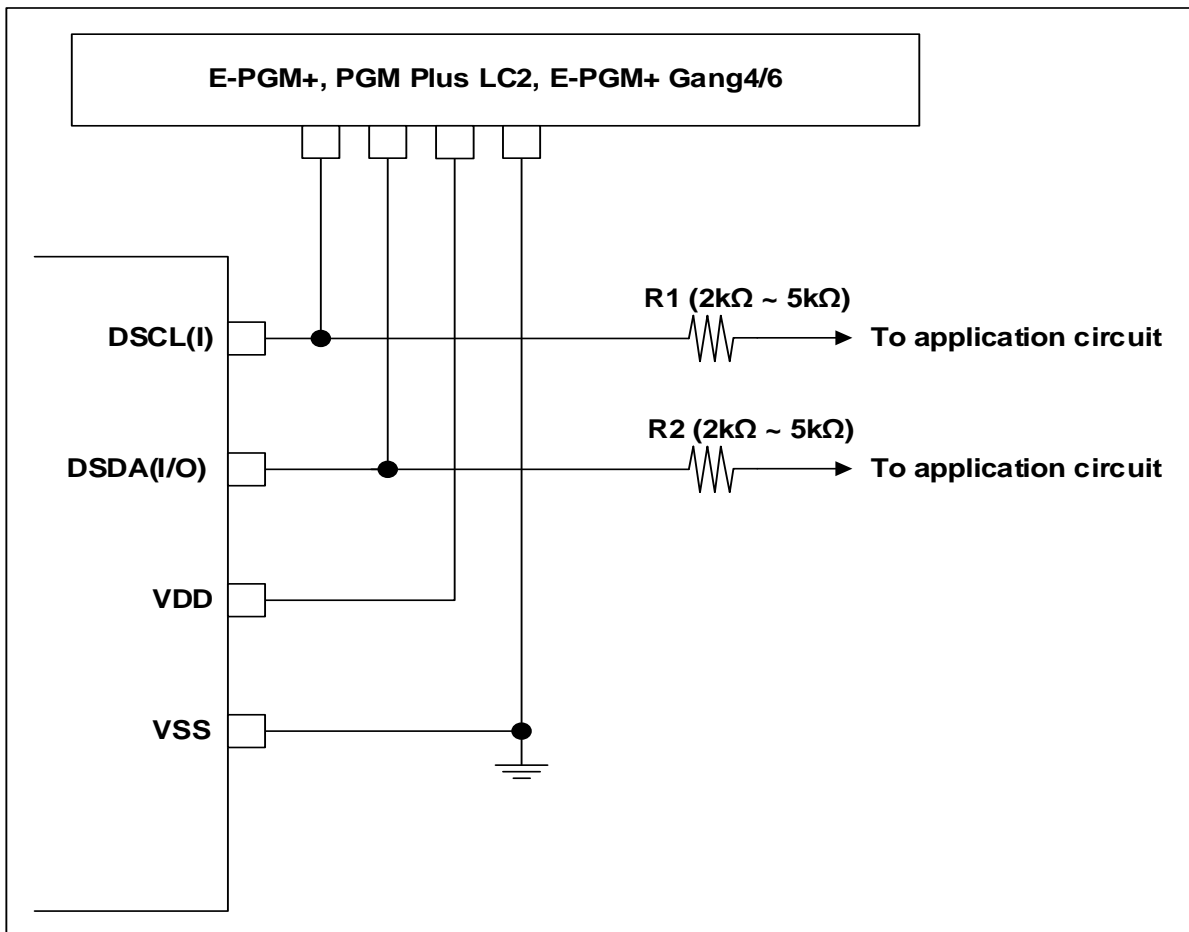

Figure 1.3 OCD Interface Circuit

**NOTE)**

1. In on-board programming mode, very high-speed signal will be provided to pin DSCL and DSDA. And it will cause some damages to the application circuits connected to DSCL or DSDA port if the application circuit is designed as high speed response such as relay control circuit. If possible, the I/O configuration of DSDA, DSCL pins had better be set to input mode.
2. The value of R1 and R2 is recommended value. It varies with circuit of system.

### 1.4.3 Programmer

#### E-PGM +

- Support ABOV / ADAM devices
- 2~5 times faster than S-PGM+
- Main controller : 32-bit MCU @ 72MHz
- Buffer memory : 1MB

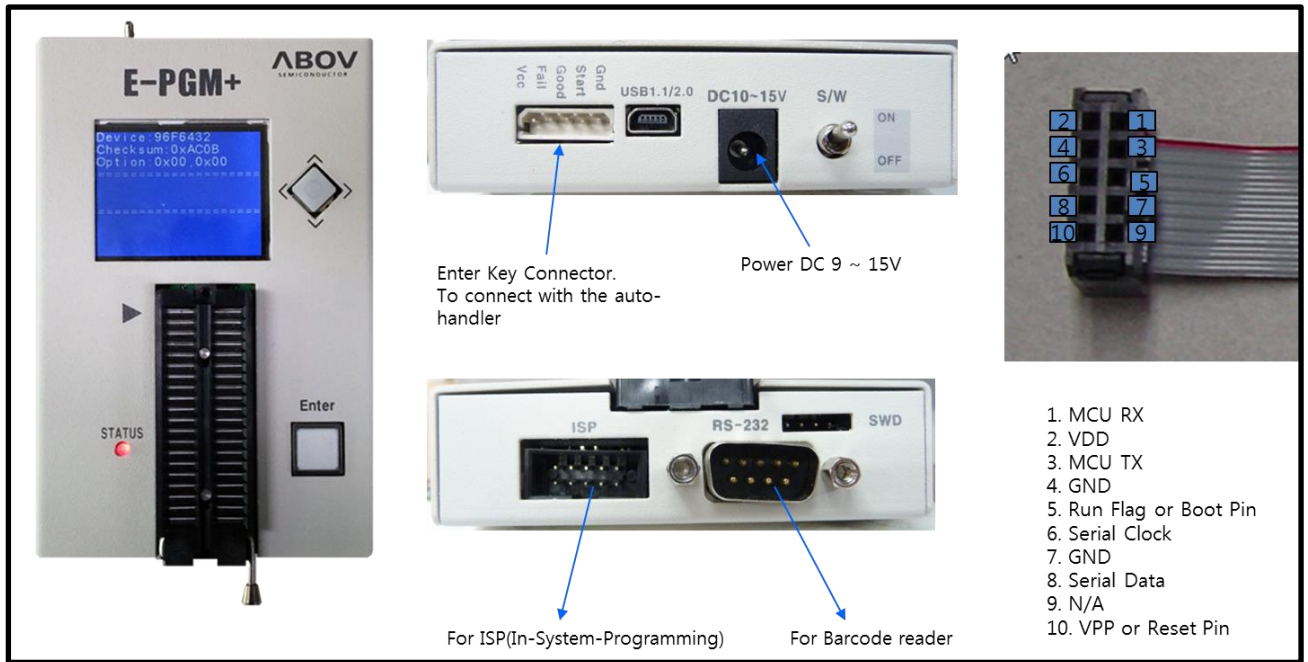

**Figure 1.4 E-PGM+ component and connector**

## PGMPlusLC 2

### Description

PGMPlusLC2 is for ISP (In System Programming). It is used to write into the MCU Which is already mounted on target board using 10pin cable.

### Features

- PGMplusLC2 is low cost writing Tool.
- USB interface is supported.
- Not need USB driver installation.
- Connect the external power adapter (5V@2A).
- Supported high voltage Max 18V.
- PGMplusLC2 is based on PC environment.
- PGMplusLC2 is faster than PGM plus LC.
- Transmission speed is 64Kbyte/s

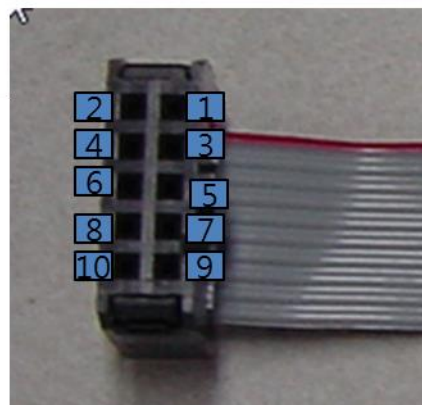
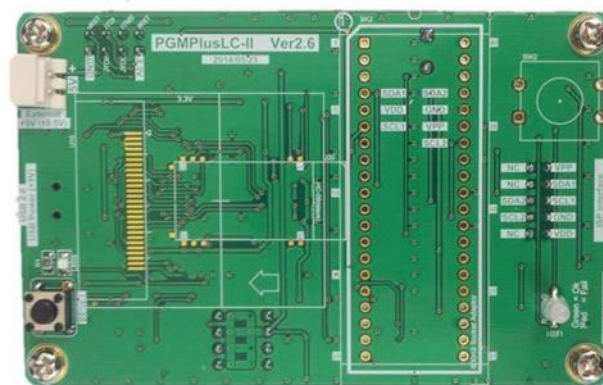

- 2. Vdd
- 4. GND
- 6. Serial Clock
- 8. Serial Data

Figure 1.5 PGMplusLC Writer



**E-PGM+ Gang4/6**

- Product name : **E-PGM+ GANG 4**
- Dimension(x , y, h) : 33.5 x 22.5 x35mm
- Weight : 2.0kg
- Input Voltage : DC Adaptor 15V/2A
- Operating Temp : -10 ~ 40°C
- Storage Temp : -30 ~ 80°C
- Water Proof : No
  
- Product name : **E-PGM+ GANG 6**
- Dimension(x , y, h) : 148.2 x 22.5 x35mm
- Weight : 2.8kg
- Input Voltage : DC Adaptor 15V/2A
- Operating Temp : -10 ~ 40°C
- Storage Temp : -30 ~ 80°C
- Water Proof : No

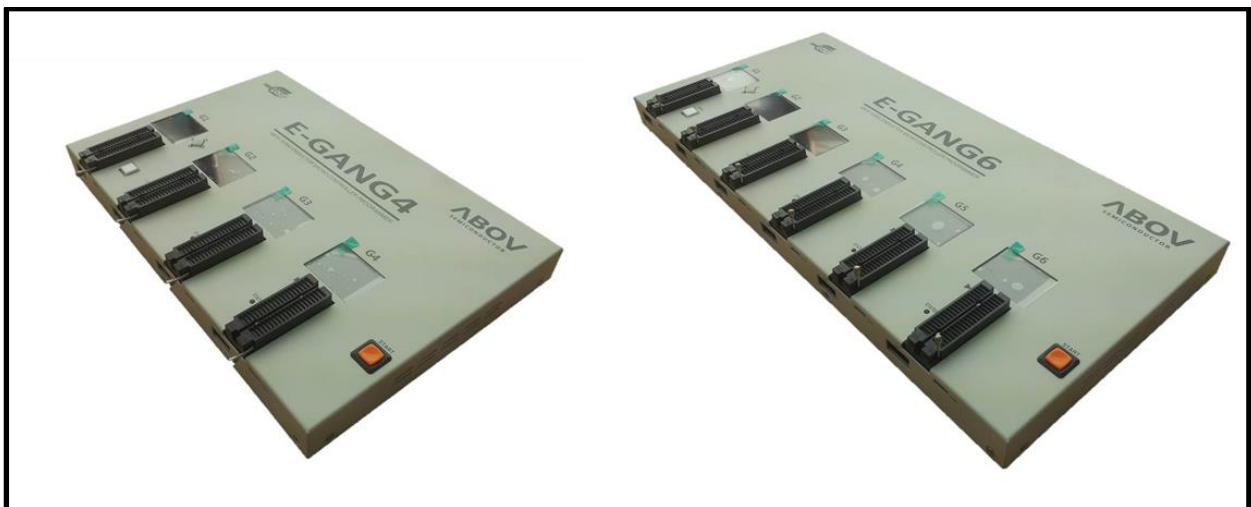

**Figure 1.6 E-PGM+ Gang4/6 Programmer**

## 2. Block Diagram

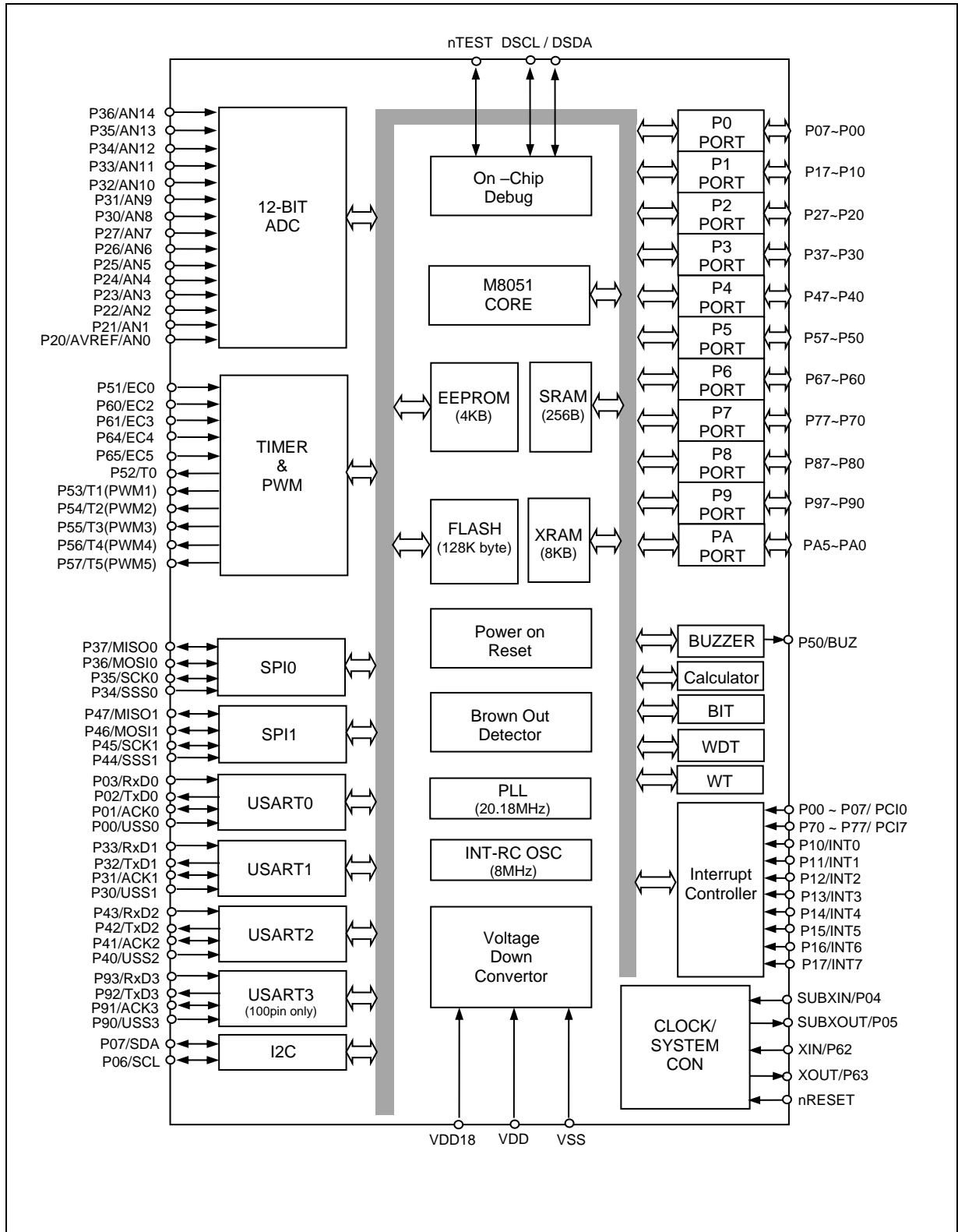

Figure 2.1 MC95FG0128A block diagram

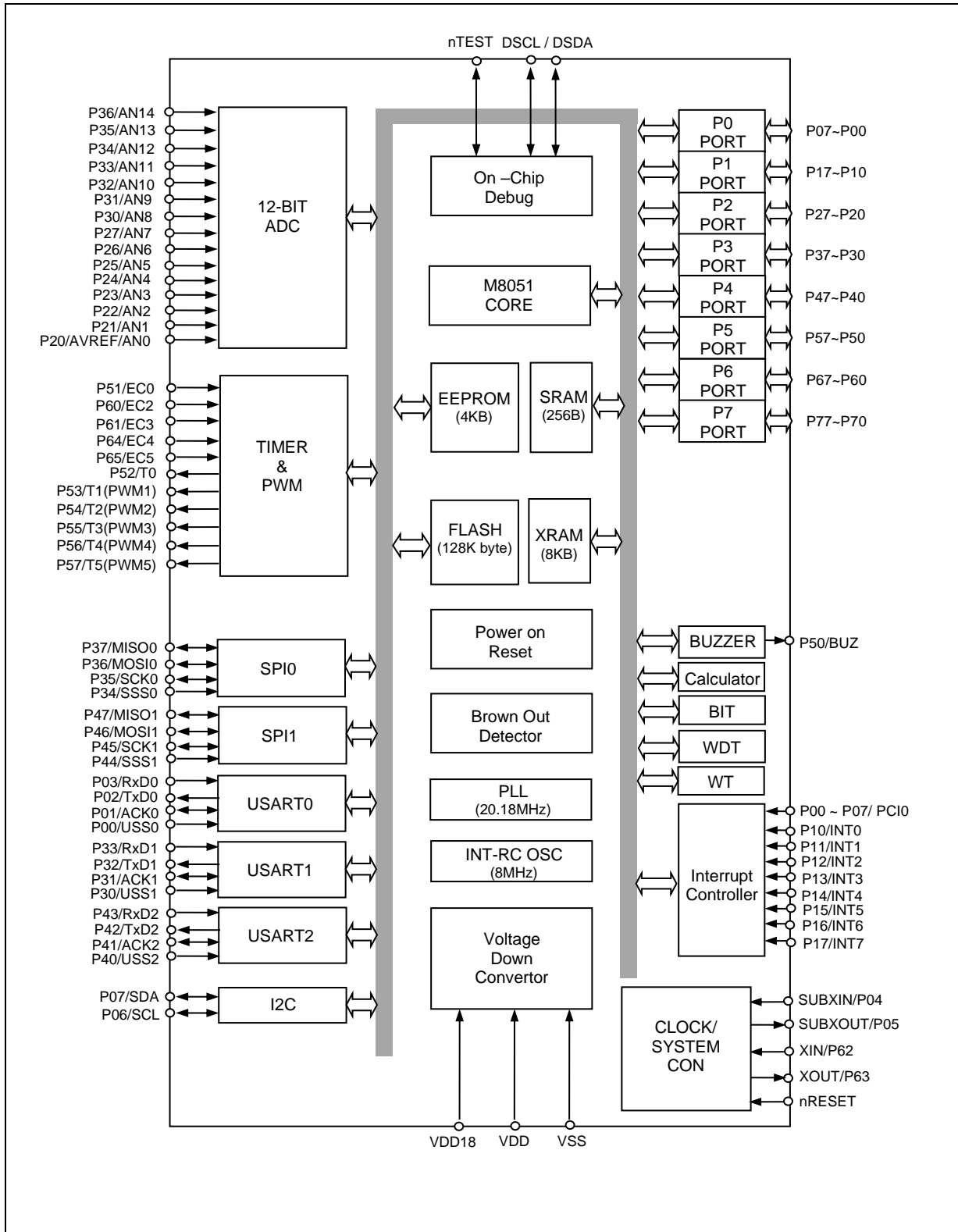

Figure 2.2 MC95FG8128A block diagram

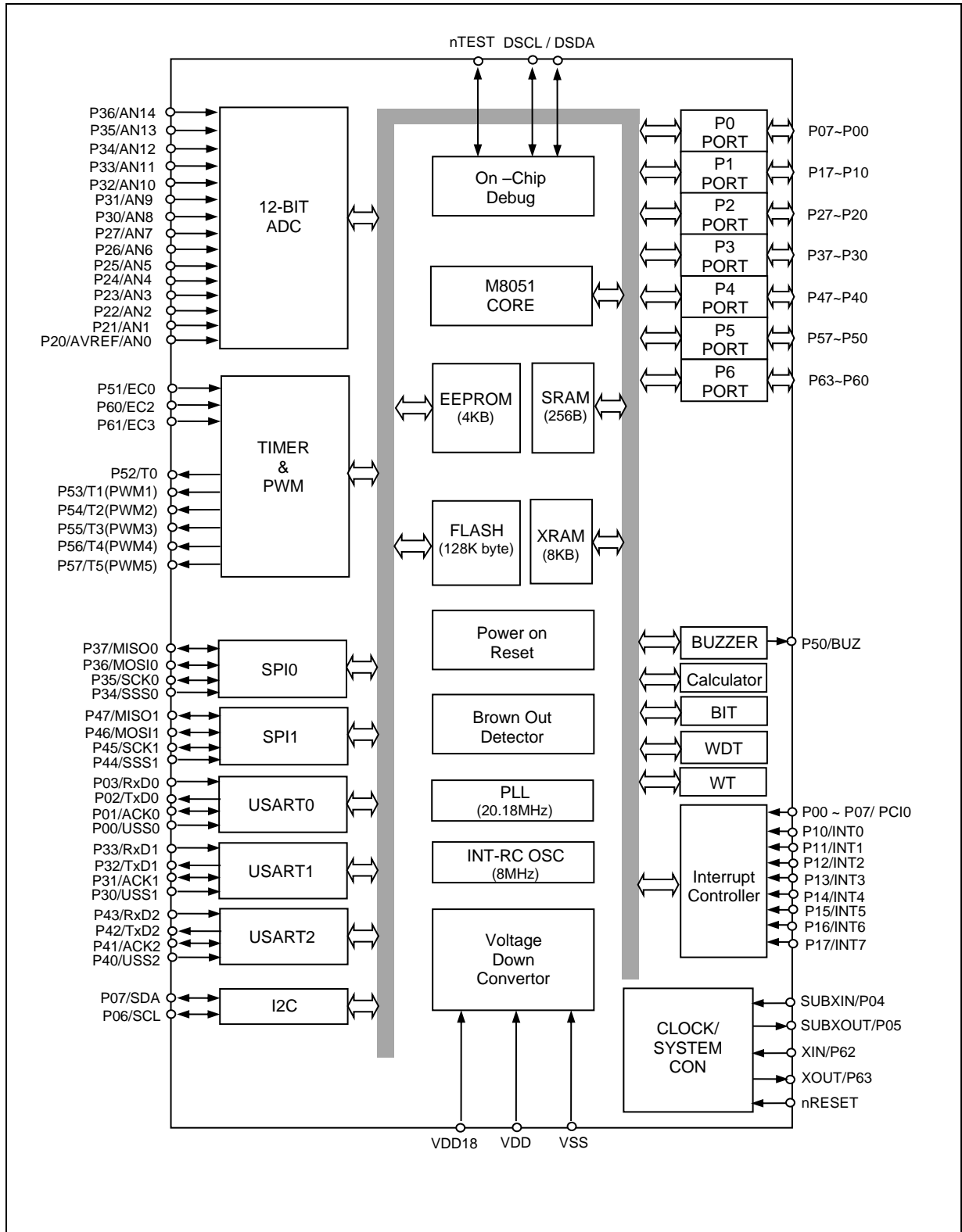

Figure 2.3 MC95FG6128A block diagram

### 3. Pin Assignmnet

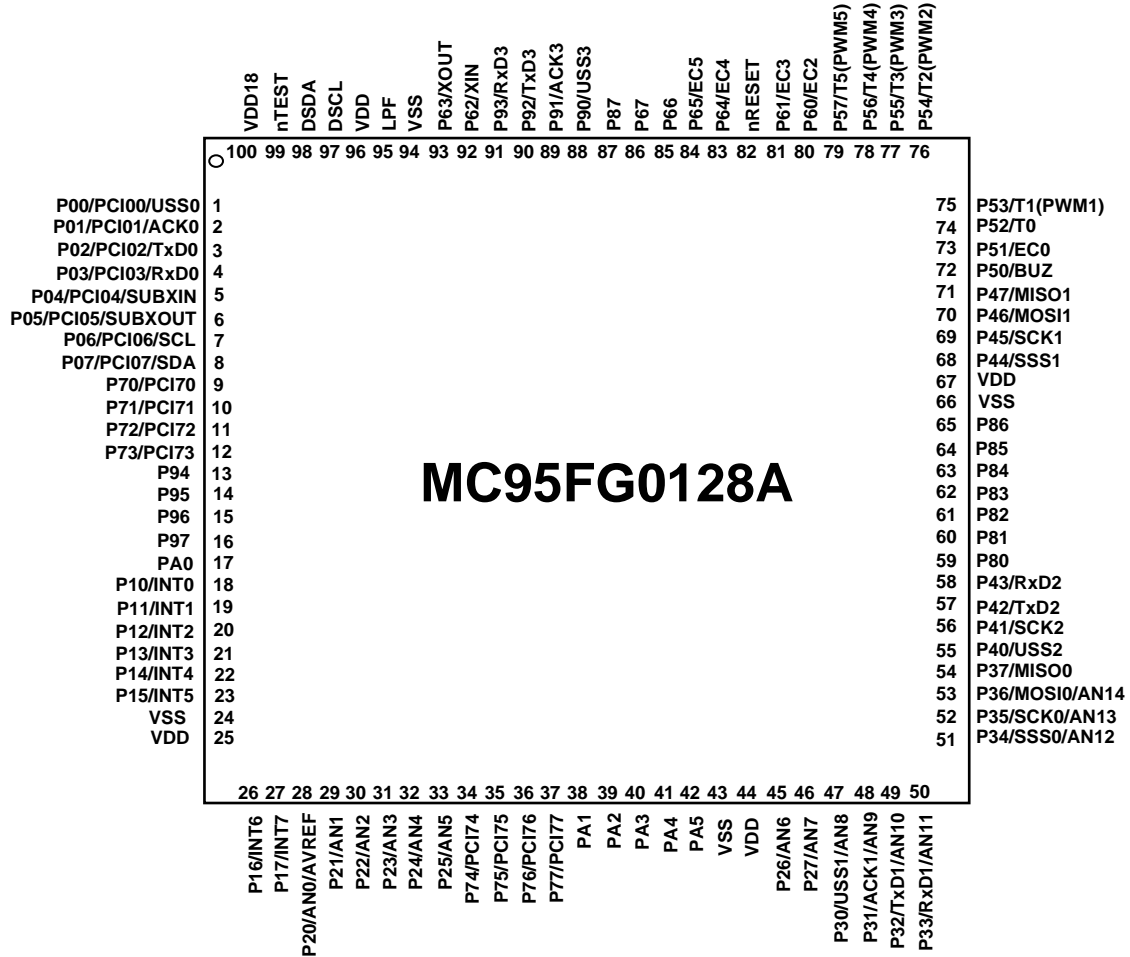

Figure 3.1 MC95FG0128A 100 Pin LQFP assignment

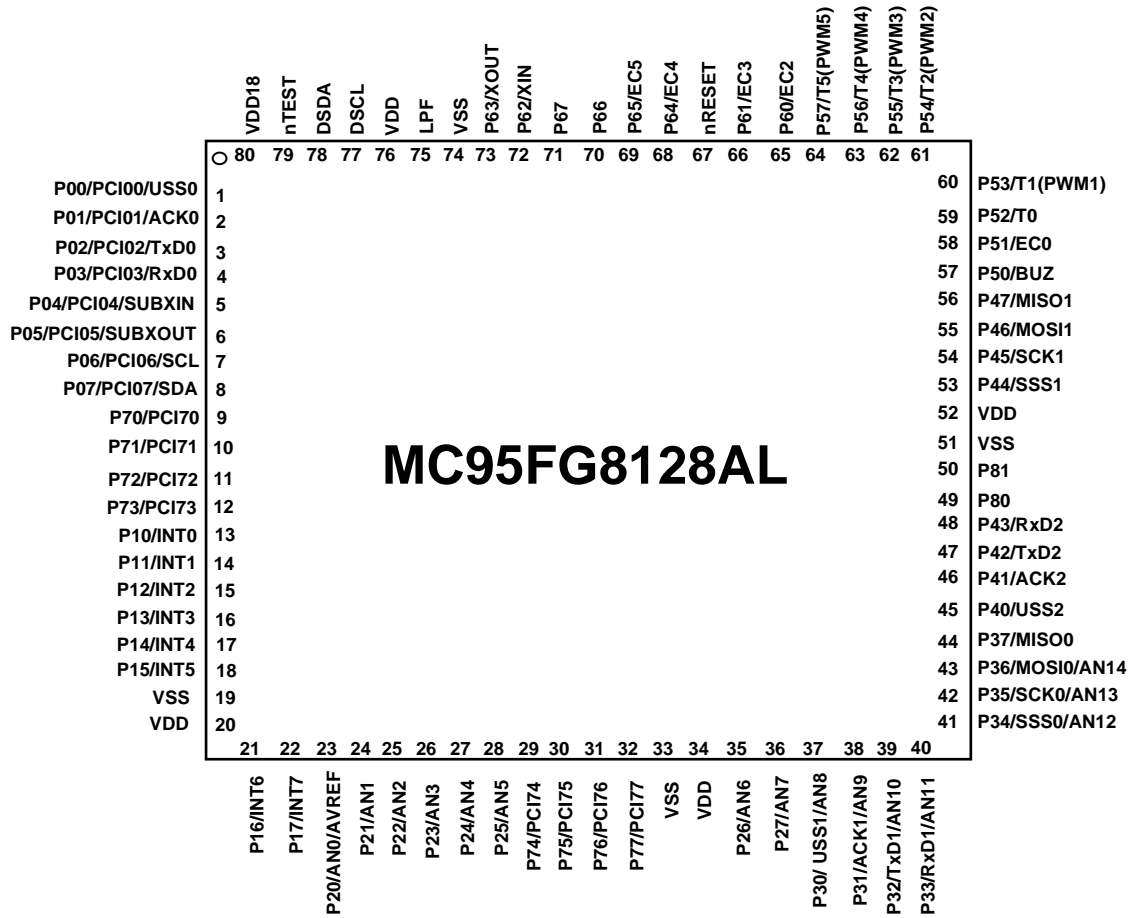

Figure 3.2 MC95FG0128A 80 Pin LQFP assignment

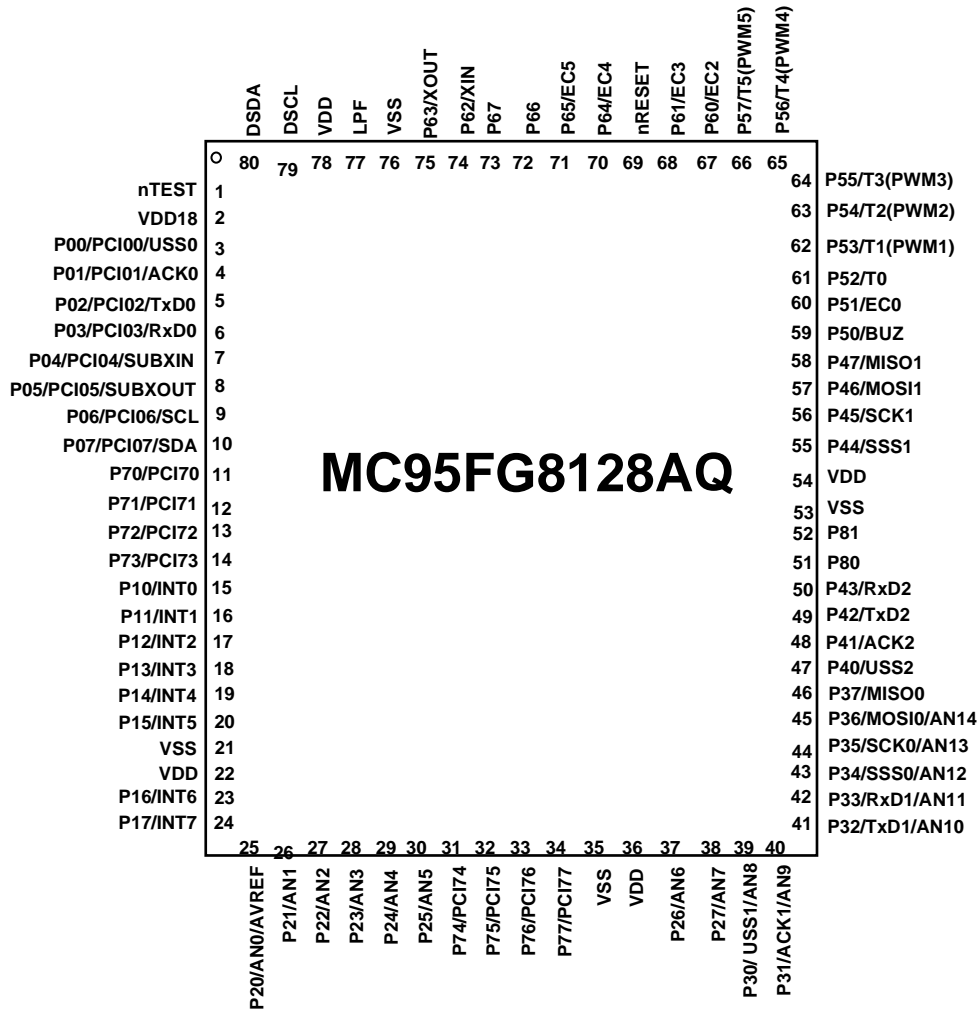

Figure 3-3 MC95FG0128A 80 Pin MQFP assignment

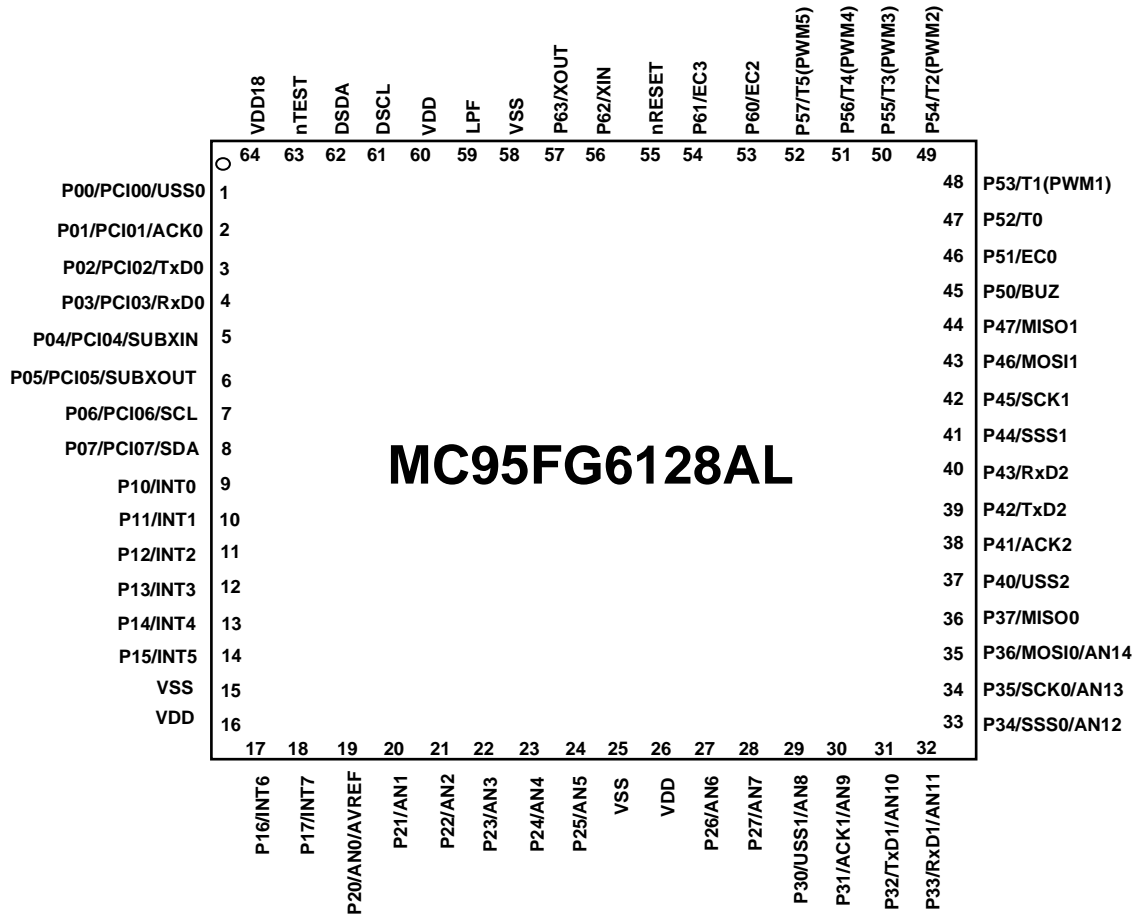

Figure 3-4 MC95FG0128A 64 pin LQFP assignment



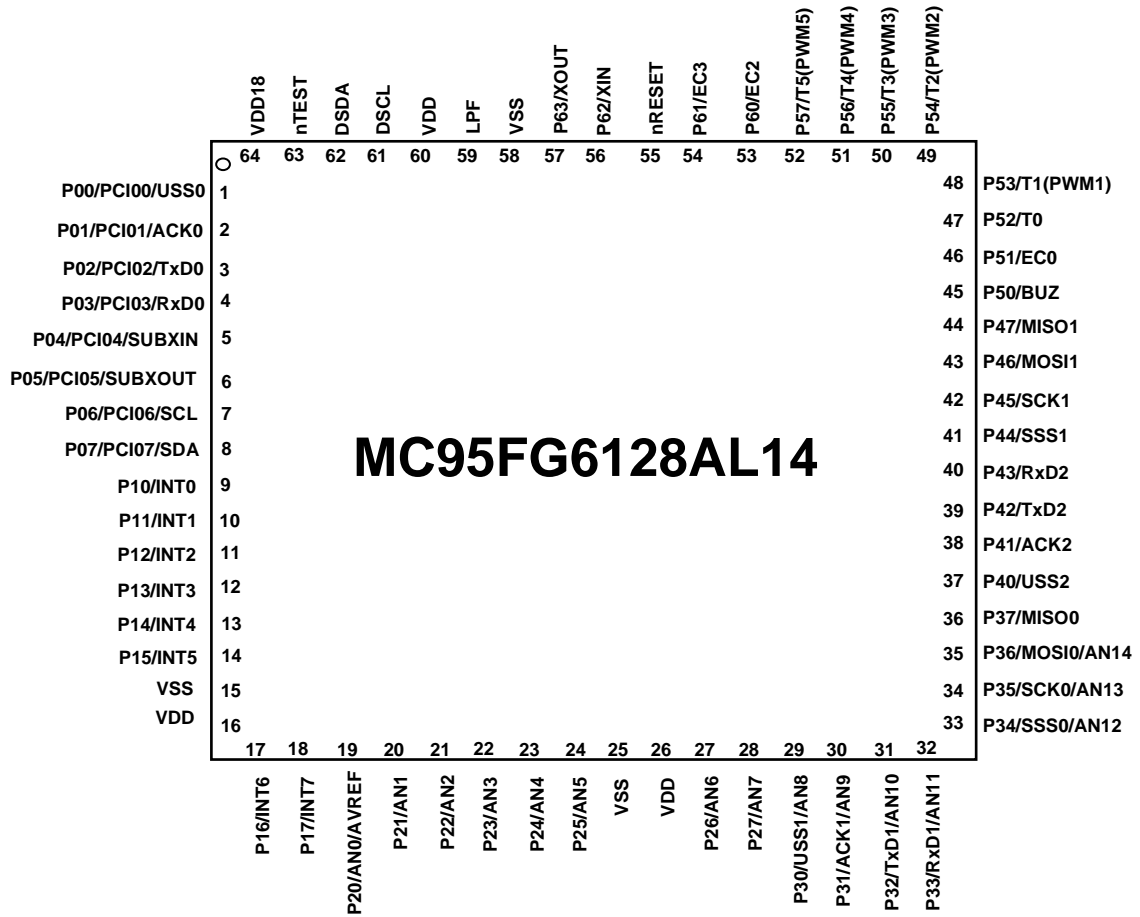

Figure 3-5 MC95FG0128A 64 pin LQFP14 assignment

### 4. Package Diagram

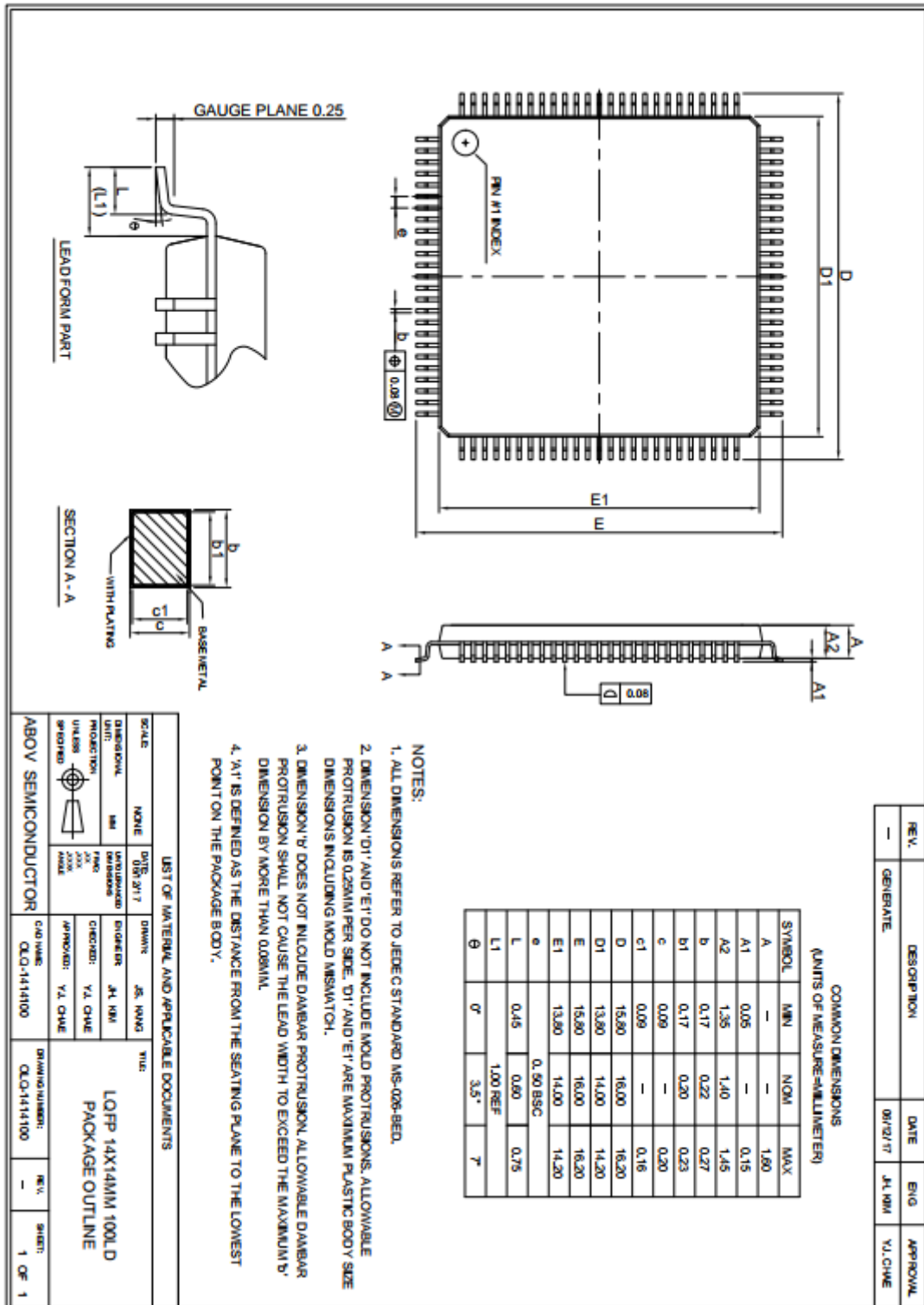

Figure 4.1 100 pin LQFP package

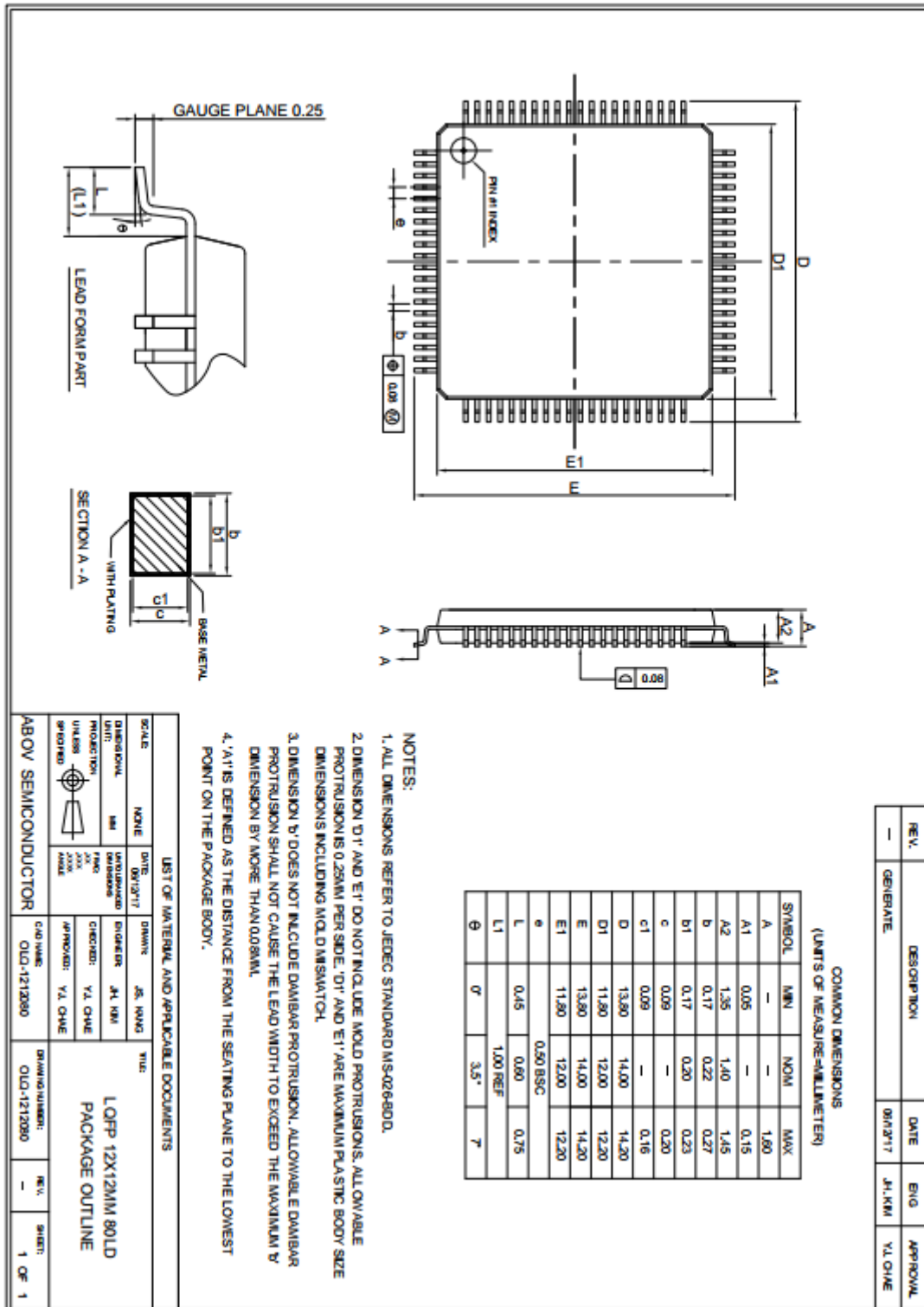

Figure 4.2 80 pin LQFP package

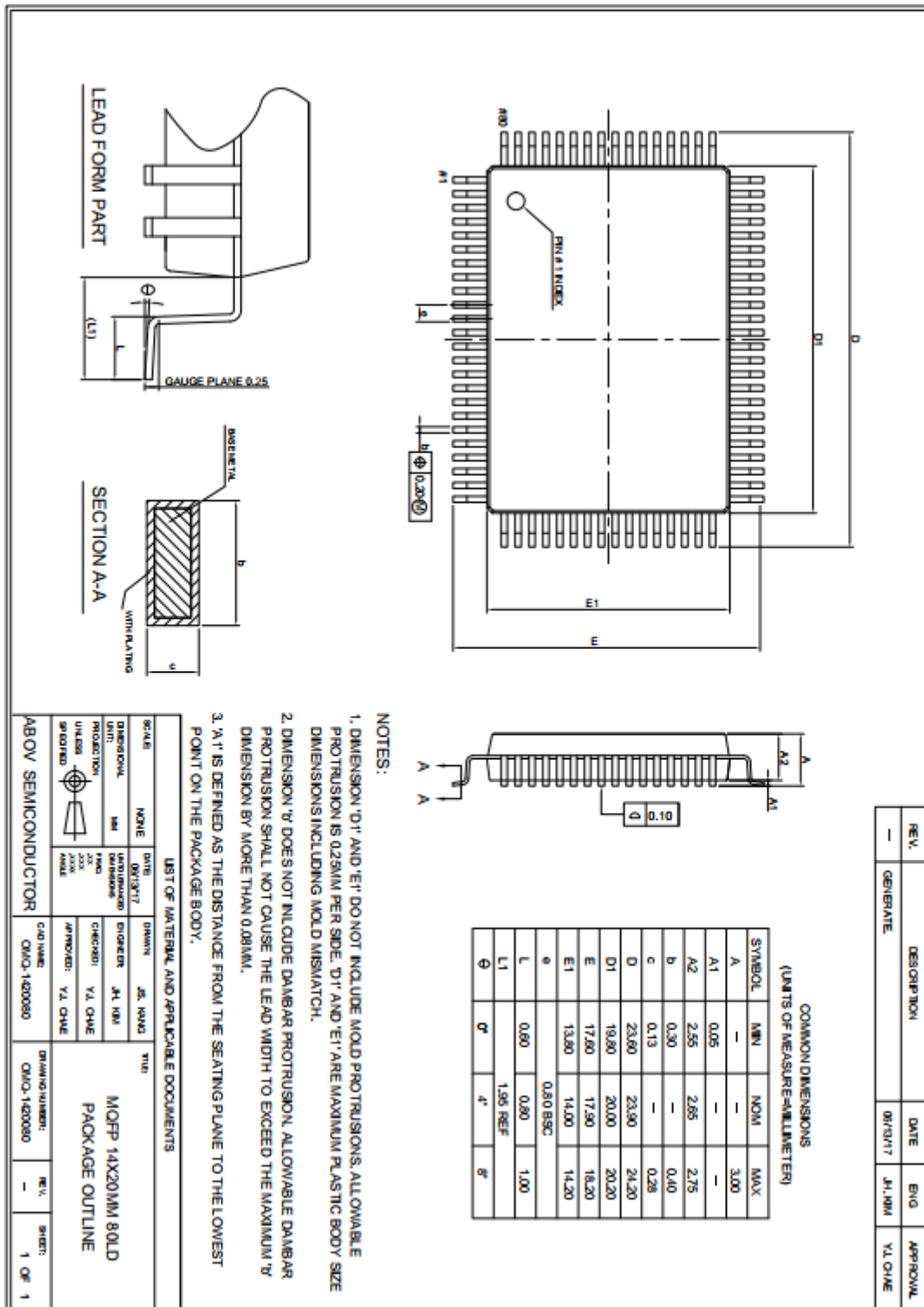

Figure 4.3 80 pin MQFP package

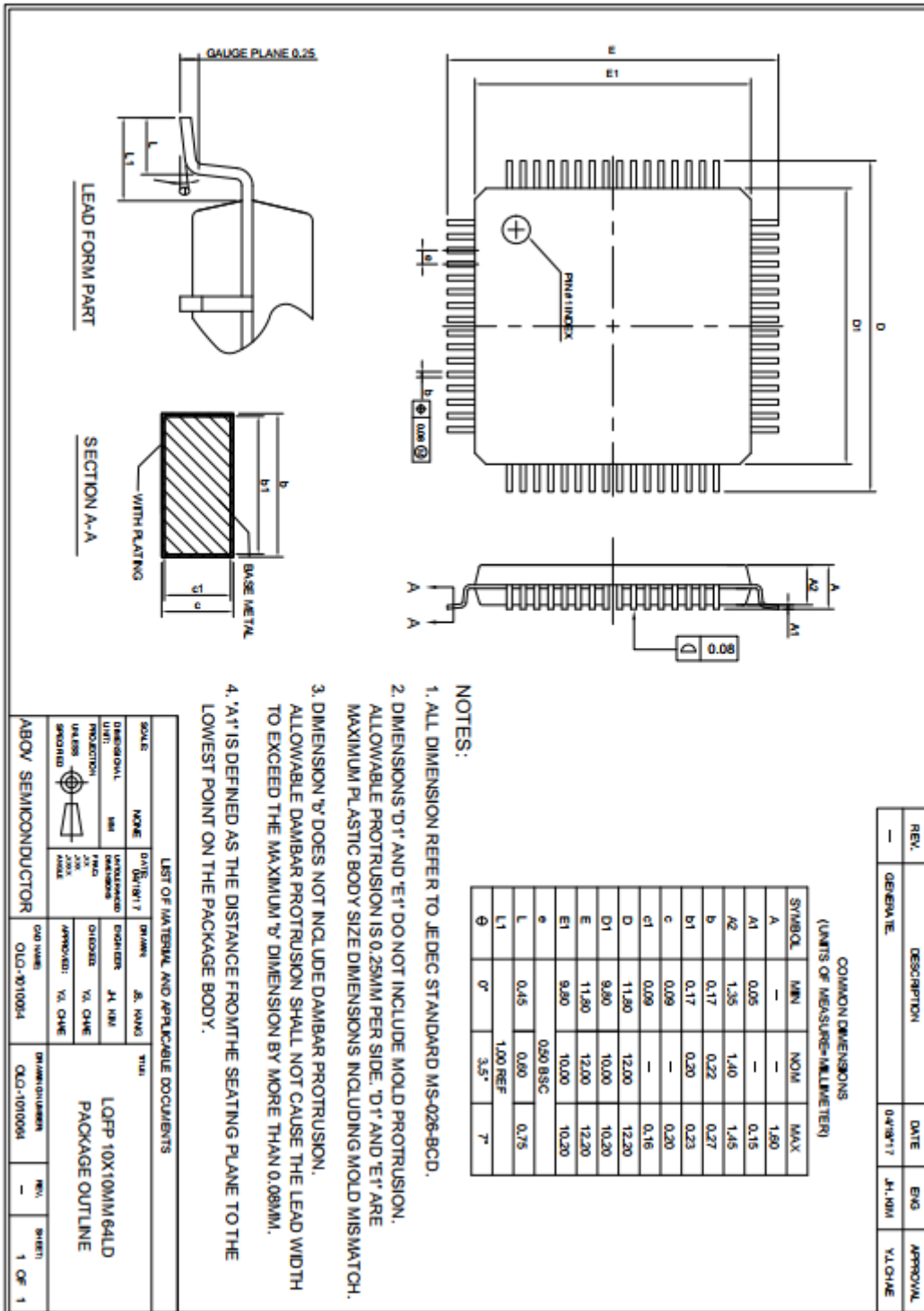

Figure 4.4 64 pin LQFP package

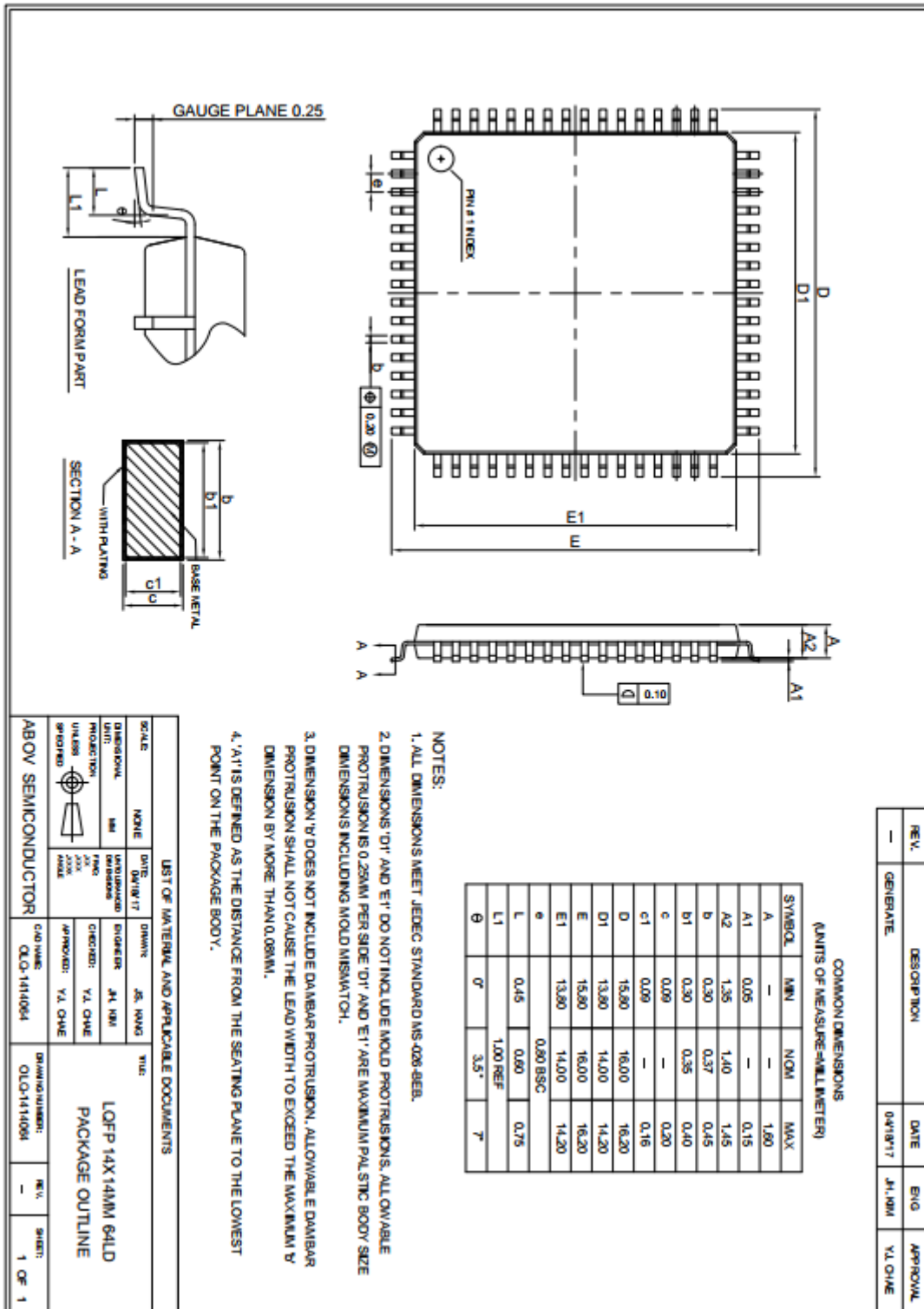

Figure 4.5 64 pin LQFP14 package

## 5. Pin Description

**Table 5-1 Normal Pin description**

PIN Name	I/O	Function	@RESET	Shared with
P00	I/O	Port P0 8-Bit I/O Port Can be set in input or output mode in 1-bit units Internal pull-up register can be used via software when this port is used as input port Open Drain enable register can be used via software when this port is used as output port	Input	USS0/PCIO
P01				ACK0/PCIO
P02				TxD0/PCIO
P03				RxD0/PCIO
P04				SUBXIN/PCIO
P05				SUBXOUT/PCIO
P06				SCL/PCIO
P07				SDA/PCIO
P10	I/O	Port P1 8-Bit I/O Port Can be set in input or output mode in 1-bit units Internal pull-up register can be used via software when this port is used as input port Open Drain enable register can be used via software when this port is used as output port	Input	INT0
P11				INT1
P12				INT2
P13				INT3
P14				INT4
P15				INT5
P16				INT6
P17				INT7
P20	I/O	Port P2 8-Bit I/O Port Can be set in input or output mode in 1-bit units Internal pull-up register can be used via software when this port is used as input port Open Drain enable register can be used via software when this port is used as output port AN0~AN7 can be selected by ADCM register	Input	AN0/AVREF
P21				AN1
P22				AN2
P23				AN3
P24				AN4
P25				AN5
P26				AN6
P27				AN7
P30	I/O	Port P3 ( <b>TTL compatible input, PAD</b> ) 8-Bit I/O Port Can be set in input or output mode in 1-bit units Internal pull-up register can be used via software when this port is used as input port	Input	AN8/USS1
P31				AN9/ACK1
P32				AN10/TxD1
P33				AN11/RxD1
P34				AN12/SSS0
P35				AN13/SCK0

P36		Open Drain enable register can be used via software when this port is used as output port AN8~AN14 can be selected by ADCM register		AN14/MOSI0
P37				MISO0
P40	I/O	Port P4 8-Bit I/O Port Can be set in input or output mode in 1-bit units Internal pull-up register can be used via software when this port is used as input port Open Drain enable register can be used via software when this port is used as output port	Input	USS2
P41				ACK2
P42				TxD2
P43				RxD2
P44				SSS1
P45				SCK1
P46				MOSI1
P47				MISO1
P50	I/O	Port P5 8-Bit I/O Port Can be set in input or output mode in 1-bit units Internal pull-up register can be used via software when this port is used as input port Open Drain enable register can be used via software when this port is used as output port	Input	BUZ
P51				EC0
P52				T0
P53				T1(PWM1)
P54				T2(PWM2)
P55				T3(PWM3)
P56				T4(PWM4)
P57				T5(PWM5)
P60	I/O	Port P6 6-Bit I/O Port Can be set in input or output mode in 1-bit units Internal pull-up register can be used via software when this port is used as input port Open Drain enable register can be used via software when this port is used as output port (P64~P67 are not used in 64 pin package)	Input	EC2
P61				EC3
P62				XIN
P63				XOUT
P64				EC4
P65				EC5
P66				-
P67				-
P70	I/O	Port P7 8-Bit I/O Port Can be set in input or output mode in 1-bit units Internal pull-up register can be used via software when this port is used as input port	Input	PCI7
P71				PCI7
P72				PCI7
P73				PCI7
P74				PCI7
P75				PCI7



P76		Open Drain enable register can be used via software when this port is used as output port (Not used in 64 pin package)		PCI7
P77				PCI7
P80	I/O	Port P8 8-Bit I/O Port Can be set in input or output mode in 1-bit units Internal pull-up register can be used via software when this port is used as input port Open Drain enable register can be used via software when this port is used as output port (Not used in 64 pin package)	Input	-
P81				-
P82				-
P83				-
P84				-
P85				-
P86				-
P87				-
P90	I/O	Port P9 8-Bit I/O Port Can be set in input or output mode in 1-bit units Internal pull-up register can be used via software when this port is used as input port Open Drain enable register can be used via software when this port is used as output port (Not used in 64, 80 pin package)	Input	USS3
P91				ACK3
P92				TxD3
P93				RxD3
P94				-
P95				-
P96				-
P97				-
PA0	I/O	Port PA 8-Bit I/O Port Can be set in input or output mode in 1-bit units Internal pull-up register can be used via software when this port is used as input port Open Drain enable register can be used via software when this port is used as output port (Not used in 64, 80 pin package)	Input	-
PA1				-
PA2				-
PA3				-
PA4				-
PA5				-
PA6				-
PA7				-
LPF	A	LPF is loop pass filter for PLL. If it doesn't use PLL, it doesn't need filter circuit and could be open(No connection).	Analog	
nRESET	I		Input	
XOUT	O	Main Oscillator output	-	
XIN	I	Main Oscillator input	-	

VSS	P		Ground	
VDD	P		Power	
SUBXOUT	O	Sub Oscillator output	-	
SUBXIN	I	Sub Oscillator input	-	
DSDA	I/O	OCD Data input/output If it doesn't use, it need pull-up resistor	Input	
D_SCL	I	OCD clock input If it doesn't use, it need pull-up resistor	Input	
nTEST	I	TEST mode enable nTEST is the same function like internal POR except remaining port configuration setting value. nTEST needs about 1k pull-up resistor.	Input	
VDD18	P	Internal 1.8V VDD VDD18 needs capacitor for VDD1.8 stable voltage.	Power	

## 6. Port Structures

### 6.1 General Purpose I/O Port

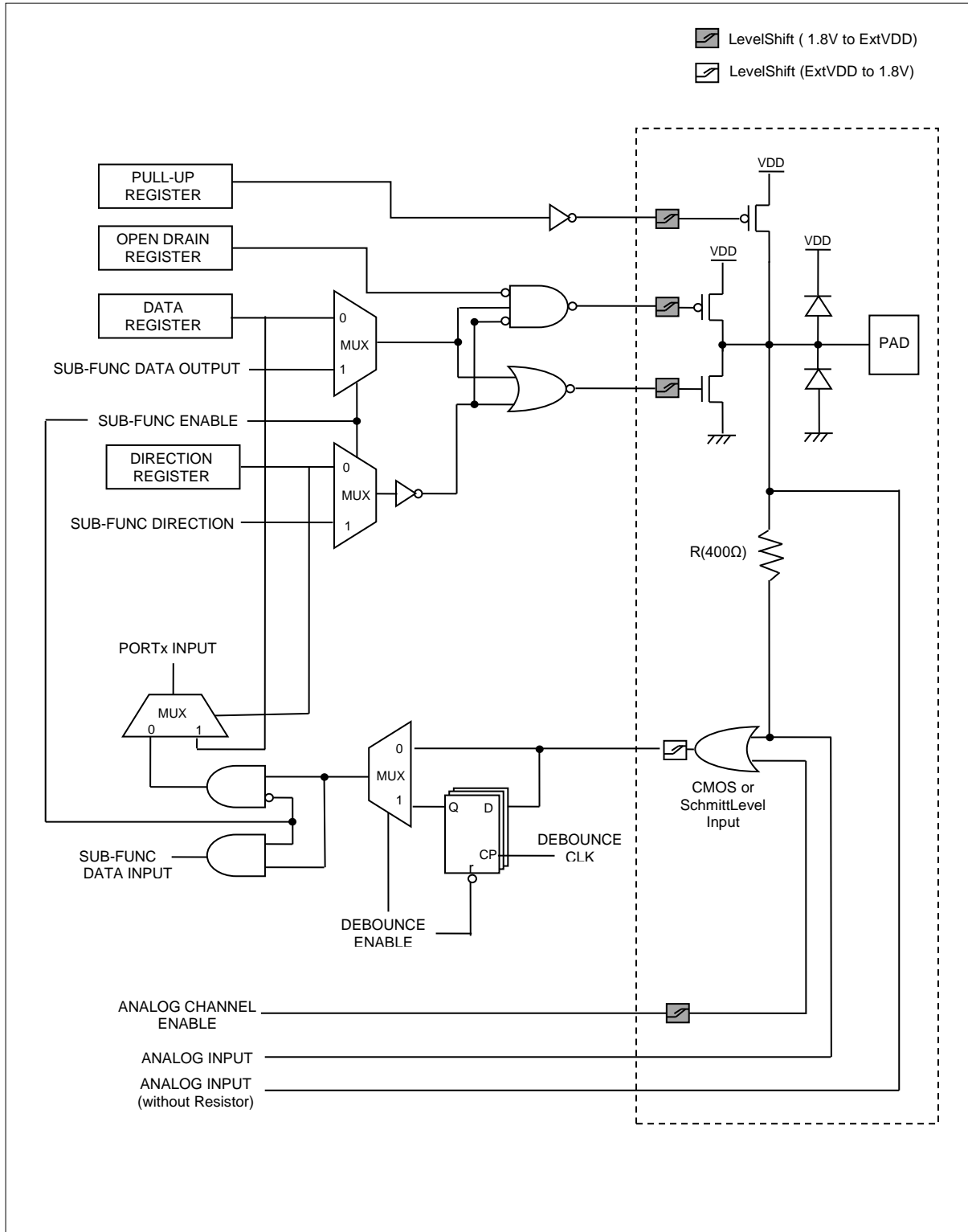

Figure 6.1 General Purpose I/O Port

### 6.2 External Interrupt I/O Port

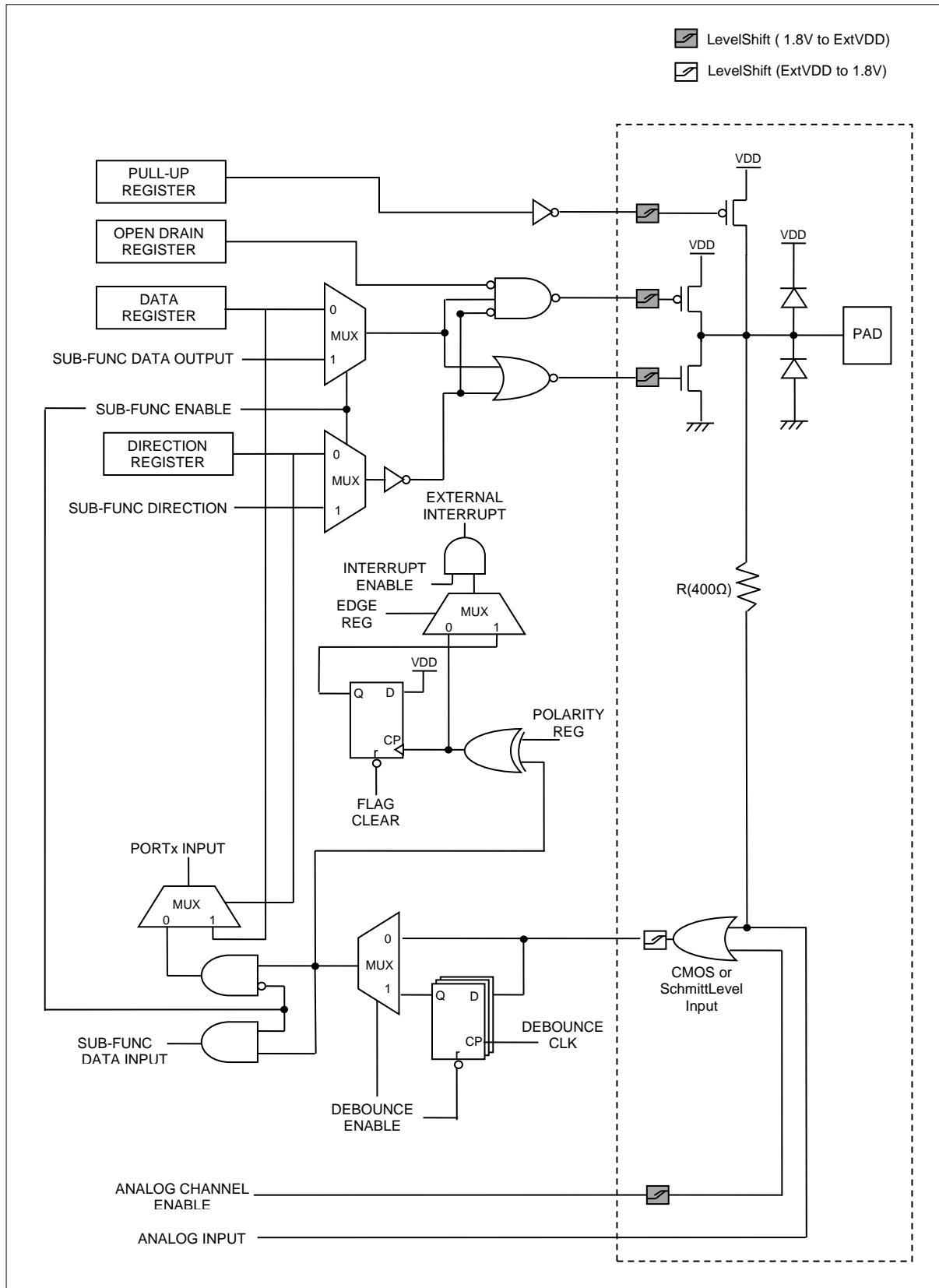

Figure 6.2 General Purpose I/O Port

## 7. Electrical Characteristics

### 7.1 Absolute Maximum Ratings

**Table 7-1 Absolute Maximum Ratings**

Parameter	Symbol	Rating	Unit
Supply Voltage	VDD	-0.3~+6.5	V
	VSS	-0.3~+0.3	V
Normal Voltage Pin	VI	-0.3~VDD+0.3	V
	VO	-0.3~VDD+0.3	V
	IOH	10	mA
	ΣIOH	80	mA
	IOL	20	mA
	ΣIOL	160	mA
	Total Power Dissipation	PT	600
Storage Temperature	TSTG	-65~+150	°C

Note) Stresses beyond those listed under “Absolute Maximum Ratings” may cause permanent damage to the device. This is a stress rating only and functional operation of the device at any other conditions beyond those indicated in the operational sections of this specification is not implied. Exposure to absolute maximum rating conditions for extended periods may affect device reliability.

### 7.2 Recommended Operating Conditions

**Table 7-2 Recommended Operation Conditions**

Parameter	Symbol	Condition	MIN	TYP	MAX	Unit
Supply Voltage	VDD	fXIN=1~10MHz	2.7	-	5.5	V
		fSUB=32.768KHz				
Operating Temperature	TOPR	VDD=2.7~5.5V	-40	-	85	°C
Operating Frequency	FOPR	fXIN	1	-	10	MHz
		fSUB	-	32.768	-	KHz
		Internal RC-OSC	-	8	-	MHz
		Internal Ring-OSC	-	1	-	MHz
		PLL	1.38	-	20.185	MHz

### 7.3 A/D Converter Characteristics

**Table 7-3 A/D Converter Characteristics**

(TA=-40°C ~ +85°C, VDD=AVDD=2.7V ~ 5.5V, VSS=0V)

Parameter	Symbol	Condition	MIN	TYP	MAX	Unit
Resolution		-	-	12	-	bits
Total Accuracy		AVDD=VDD=5.12V fXIN=4MHz		-	±3	lsb
Integral Linear Error	INL		-	-	±2	lsb
Differential Linearity Error	DLE		-	-	±2	lsb
Zero Offset Error	ZOE		-	-	±3	lsb
Full Scale Error	FSE		-	-	±3	lsb
Conversion Time	tCON	12bit conversion max 3MHz	-	60	-	cycle
Analog Input Voltage	VAN	-	VSS	-	AVDD=VDD	V
Analog Power Voltage	AVDD	-	-	*AVDD=VDD	-	V
Analog Reference Voltage	AVREF	(note)	1.8	-	5.5	V
Analog Ground Voltage	AVSS	-	-	VSS	-	V
Analog Input Leakage Current		AVDD=VDD=5.12V	-	-	10	uA
ADC Operating Current	IDD	AVDD=VDD=5.12V	-	1	3	mA
	SIDD		-	-	1	uA

(note) When AVREF is lower than 2,7V, the ADC resolution is worse.

### 7.4 Voltage Dropout Converter Characteristics

**Table 7-4 Voltage Dropout Converter Characteristics**

Parameter	Symbol	Condition	MIN	TYP	MAX	Unit
Operating Voltage		-	1.8	-	5.5	V
Operating Temperature		-	-40	-	+85	°C
Regulation Voltage		-	1.62	1.8	1.98	V
Drop-out Voltage		-	-	-	0.02	V
Current Drivability		RUN/IDLE	-	20	-	mA
		SUB-ACTIVE	-	1	-	mA
		STOP1	-	50	-	uA
		STOP2	-	10	-	uA
Operating Current	IDD1	RUN/IDLE	-	-	1	mA
	IDD2	SUB-ACTIVE	-	-	0.1	mA
	SIDD1	STOP1	-	-	5	uA
	SIDD2	STOP2	-	-	0.1	uA
Drivability Transition Time	TRAN1	SUB to RUN	-	-	1	us

	TRAN2	STOP to RUN	-	-	200	us
--	-------	-------------	---	---	-----	----

Note) -STOP1: WDT running - STOP2: WDT disable

## 7.5 Power-On Reset Characteristics

Table 7-5 Power-On Reset Characteristics

Parameter	Symbol	Condition	MIN	TYP	MAX	Unit
Operating Voltage		-	VSS	-	5.5	V
Operating Temperature		-	-40	-	+85	°C
RESET Release Level		-	1.3	1.4	1.5	V
Operating Current	IDD	-	-	-	10	uA
	SIDD	-	-	-	1	uA

## 7.6 Brown Out Detector Characteristics

Table 7-6 Brown Out Detector Characteristics

Parameter	Symbol	Condition	MIN	TYP	MAX	Unit
Operating Voltage		-	VSS	-	5.5	V
Operating Temperature		-	-40	-	+85	°C
Detection Level	4.2V	-	4.0	-	4.4	V
	3.6V	-	3.4	-	3.8	V
	2.5V	-	2.3	-	2.7	V
	1.6V	-	1.4	-	1.8	V
Hysteresis		-	-	-	-	mV
Operating Current	IDD	-	-	-	50	uA
	SIDD	-	-	-	1	uA

## 7.7 Internal RC Oscillator Characteristics

Table 7-7 Internal RC Oscillator Characteristics

Parameter	Symbol	Condition	MIN	TYP	MAX	Unit
Operating Voltage		-	1.8	-	5.5	V
Tolerance	-	T <sub>A</sub> = 25°C	With 0.1uF Bypass capacitor	-	±1.5	%
		T <sub>A</sub> = -20°C to +60°C			±2.5	
		T <sub>A</sub> = -40°C to +85°C			±3.0	
Frequency		-	-	8	-	MHz
Stabilization Time		-	-	-	10	ms
Operating Current	IDD	-	-	-	-	uA
	SIDD	-	-	-	1	uA

## 7.8 Ring-Oscillator Characteristics

Table 7-8 Ring-Oscillator Characteristics

Parameter	Symbol	Condition	MIN	TYP	MAX	Unit
Operating Voltage		-	1.8	-	5.5	V
Operating Temperature		-	-40	-	+85	°C
Frequency		-	0.5	1	1.5	MHz
Stabilization Time		-	-	-	-	ms
Operating Current	IDD	-	-	-	-	uA
	SIDD	-	-	-	1	uA

## 7.9 PLL Characteristics

( TA = 0°C ~ +70°C, VDD18 = 1.6V ~ 2.0V, VSS = 0V )

Table 7-9 PLL Characteristics

Parameter	Symbol	Min.	Typ.	Max.	Units	Conditions
PLL current	I <sub>PLL</sub>	-	0.5	TBD	mA	
Input clock frequency	f <sub>xin</sub>	-	32.768	-	kHz	
Output clock frequency	f <sub>out</sub>	1.38	-	20.18	MHz	
Output clock duty	-	45	-	55	%	
Setting time	t <sub>D</sub>	-	1	-	ms	
Accuracy	-	-	2	-	%	



## 7.10 DC Characteristics

**Table 7-10 DC Characteristics**

(VDD =2.7~5.5V, VSS =0V, fXIN=10.0MHz, TA=-40~+85℃)

Parameter	Symbol	Condition	MIN	TYP	MAX	Unit
Input Low Voltage	VIL1	nTEST, nRESET, DSCL, DSDA	-0.5	-	0.2VDD	V
	VIL2	P0,P1,P2,P4,P5,P6,P7,P8,P9,PA	-0.5	-	0.2VDD	V
	VIL3	P3 (VDD=4.0~5.5V)	-0.5	-	0.1VDD+0.4	V
	VIL4	P3 (VDD=2.7~4.0V)	-0.5	-	0.2VDD	V
Input High Voltage	VIH1	nTEST, nRESET, DSCL, DSDA	0.8VDD	-	VDD	V
	VIH2	P0,P1,P2,P4,P5,P6,P7,P8,P9,PA	0.7VDD	-	VDD	V
	VIH3	P3	0.3VDD+0.7	-	VDD	V
Output Low Voltage	VOL1	ALL I/O (IOL=20mA, VDD=4.5V)	-	-	1	V
Output High Voltage	VOH1	ALL I/O (IOH=-8.57mA, VDD=4.5V)	3.5	-	-	V
Input High Leakage Current	IIH	ALL PAD	-	-	1	uA
Input Low Leakage Current	IIL	ALL PAD	-1	-	-	uA
Pull-Up Resister	RPU	ALL PAD (except DSCL, DSDA)	20	-	50	kΩ
Power Supply Current	IDD1	Run Mode, fXIN=10MHz @5V	-	*3.7	15	mA
	IDD2	Sleep Mode, fXIN=10MHz @5V	-	*2	10	mA
	IDD3	Sub Active Mode, fSUBXIN=32.768kHz @5V (PLL enable)	-	*0.4	1	mA
	IDD4	Sub Active Mode, fSUBXIN=32.768kHz @5V (PLL disable)	-	*132	500	uA
	IDD5	STOP1 Mode, WDT Active @5V (BOD enable)	-	*124	200	uA
	IDD6	STOP1 Mode, WDT Active @5V (BOD disable)	-	*48	100	uA
	IDD7	STOP2 Mode, WDT Disable @5V (BOD enable)	-	*77	110	uA
	IDD8	STOP2 Mode, WDT Disable @5V (BOD disable)	-	*2	7 (room temp)	uA

Note) - STOP1: WDT running, STOP2: WDT disable.

- (\*) typical test condition : VDD=5V, Internal RC-OSC=8MHz, ROOM TEMP, all PORT output LOW, Timer0 Active, 1PORT toggling.

### 7.11 AC Characteristics

Table 7-11 AC Characteristics

(VDD=5.0V±10%, VSS=0V, TA=-40~+85°C)

Parameter	Symbol	PIN	MIN	TYP	MAX	Unit
Operating Frequency	fMCP	XIN	1	-	10	MHz
System Clock Cycle Time	tSYS	-	100	-	1000	ns
Oscillation Stabilization Time (8MHz)	tMST1	XIN, XOUT	-	-	10	ms
External Clock "H" or "L" Pulse Width	tCPW	XIN	90	-	-	ns
External Clock Transition Time	tRCP,tFCP	XIN	-	-	10	ns
External Interrupt Input Width	tIW	INT0~INTx	2	-	-	tSYS
External Interrupt Transition Time	tFI,tRI	INT0~INTx			1	us
nRESET Input Pulse "L" Width	tRST	nRESET	8	-	-	tSYS
External Counter Input "H" or "L" Pulse Width	tECW	EC0~ECx	2	-	-	tSYS
Event Counter Transition Time	tREC,tFEC	EC0~ECx	-	-	20	ns

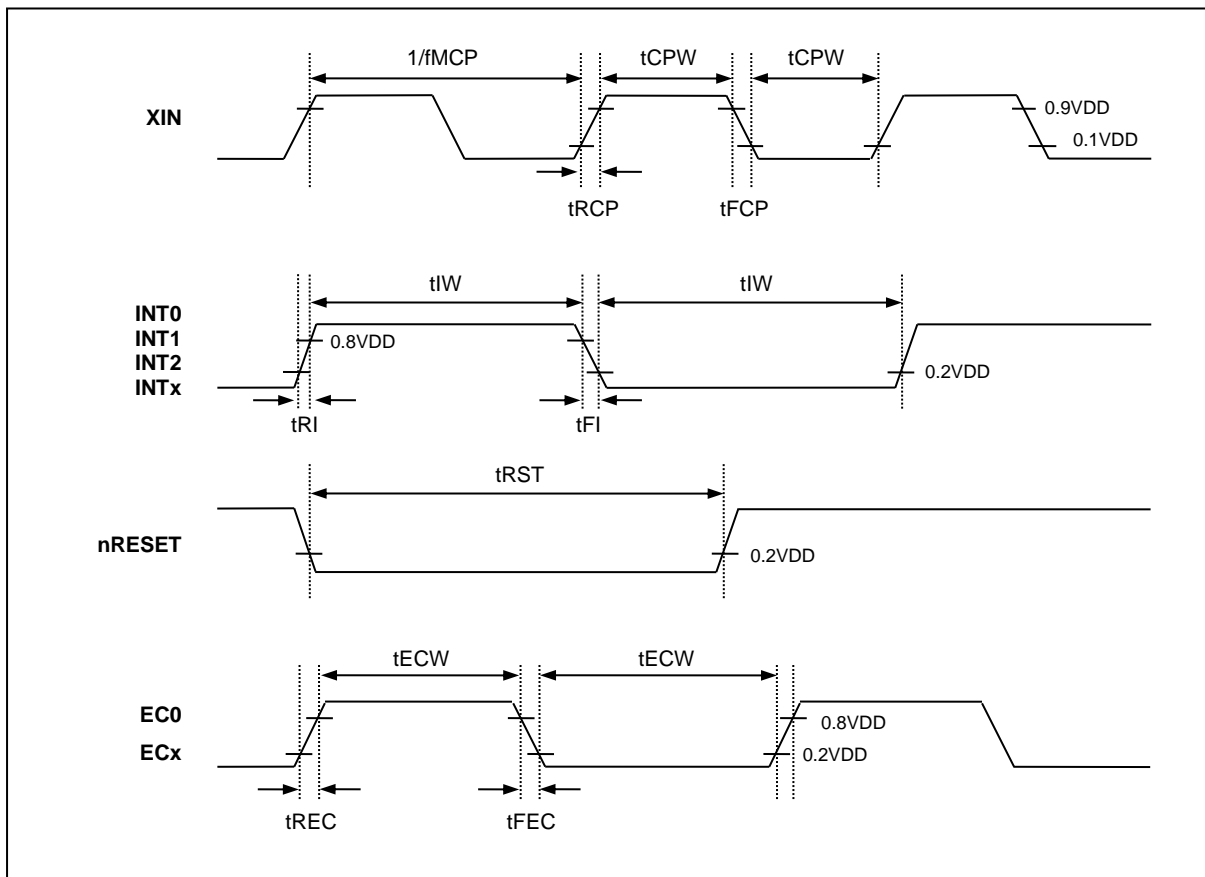

Figure 7.1 AC Timing

### 7.12 SPI Characteristics

Table 7-12 SPI Characteristics

(VDD=5.0V±10%, VSS=0V, TA=-40~+85°C)

Parameter	Symbol	PIN	MIN	TYP	MAX	Unit
Output Clock Pulse Period	tSCK	SCK	-	SPI clock mode	-	ns
Input Clock Pulse Period	tSCK	SCK	2 • tSYS	-	-	ns
Input Clock "H" or "L" Pulse Width	tSCKL, tSCKH	SCK		50% duty	-	ns
Input Clock Pulse Transition Time	tFSCK, tRSCK	SCK	-	-	30	ns
Output Clock "H" or "L" Pulse Width	tSCKL, tSCKH	SCK	tSYS-30	-	-	ns
Output Clock Pulse Transition Time	tFSCK, tRSCK	SCK	-	-	30	ns
First Output Clock Delays Time	tFOD	OUTPUT				
Output Clock Delay Time	tDS	OUTPUT	-	-	100	ns
Input Pulse Transition Time	tFSIN, tRSIN	INPUT	-	-	30	ns
Input Setup Time	tDIS	INPUT	100		-	ns
Input Hold Time	tDIH	INPUT	tSYS+70	-	-	ns

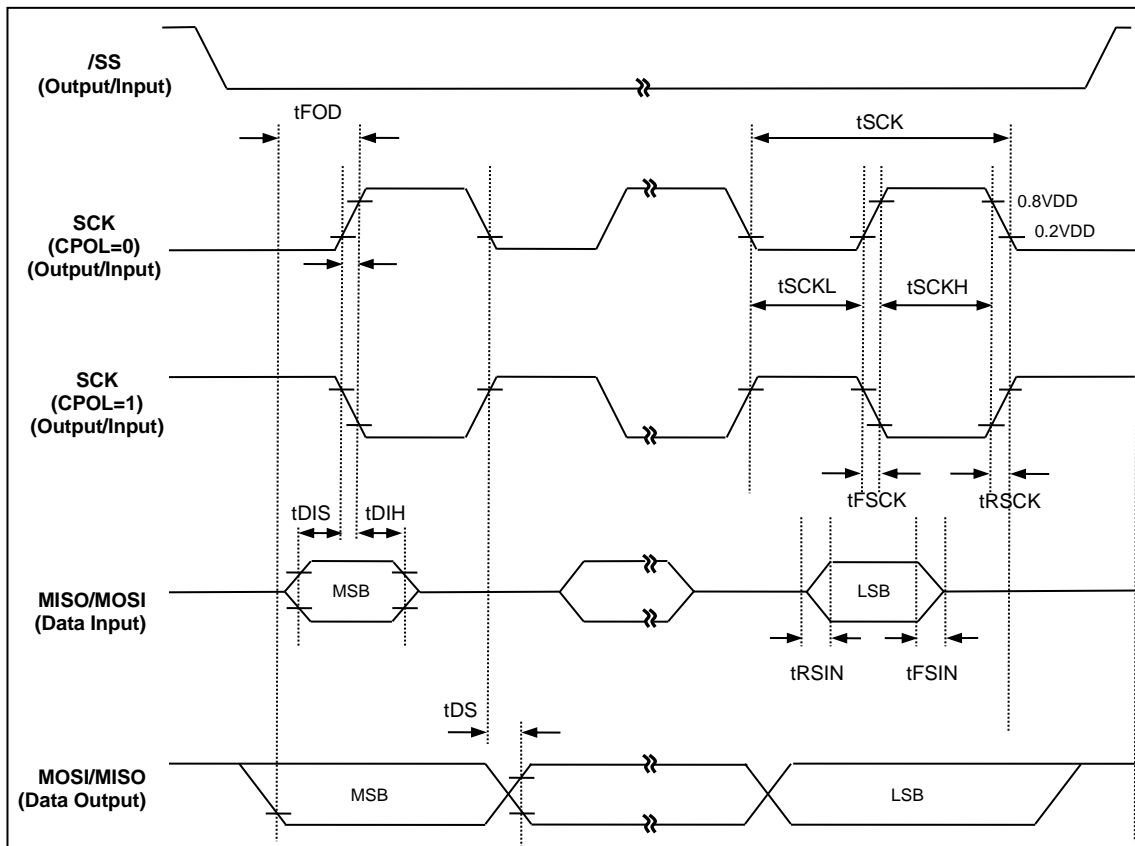

Figure 7.2 SPI Timing

### 7.13 Typical Characteristics

These graphs and tables provided in this section are for design guidance only and are not tested or guaranteed. In some graphs or tables the data presented are outside specified operating range (e.g. outside specified VDD range). This is for information only and devices are guaranteed to operate properly only within the specified range.

The data presented in this section is a statistical summary of data collected on units from different lots over a period of time. "Typical" represents the mean of the distribution while "max" or "min" represents  $(\text{mean} + 3\sigma)$  and  $(\text{mean} - 3\sigma)$  respectively where  $\sigma$  is standard deviation.

## 8. Memory

The MC95FG0128A addresses two separate address memory stores: Program memory and Data memory. The logical separation of Program and Data memory allows Data memory to be accessed by 8-bit addresses, which can be more quickly stored and manipulated by 8-bit CPU. Nevertheless, 16-bit Data memory addresses can also be generated through the DPTR register.

Program memory can only be read, not written to. There can be up to 64K bytes of Program memory in a bank. In the MC95FG0128A FLASH version of these devices the 128K bytes of Program memory are provided on-chip. Data memory can be read and written to up to 256 bytes internal memory (DATA) including the stack area and 8K bytes of external data memory(XRAM).

### 8.1 Program Memory

A 16-bit program counter is capable of addressing up to 64K bytes for one bank of memory space, but this device has 128K bytes program memory space with bank selection scheme.

Figure 8.1 shows a map of the lower part of the program memory. After reset, the CPU begins execution from location 0000H. Each interrupt is assigned a fixed location in program memory. The interrupt causes the CPU to jump to that location, where it commences execution of the service routine. External interrupt 0, for example, is assigned to location 0003H. If external interrupt 0 is going to be used, its service routine must begin at location 0003H. If the interrupt is not going to be used, its service location is available as general purpose program memory. If an interrupt service routine is short enough (as is often the case in control applications), it can reside entirely within that 8 byte interval. Longer service routines can use a jump instruction to skip over subsequent interrupt locations, if other interrupts are in use.

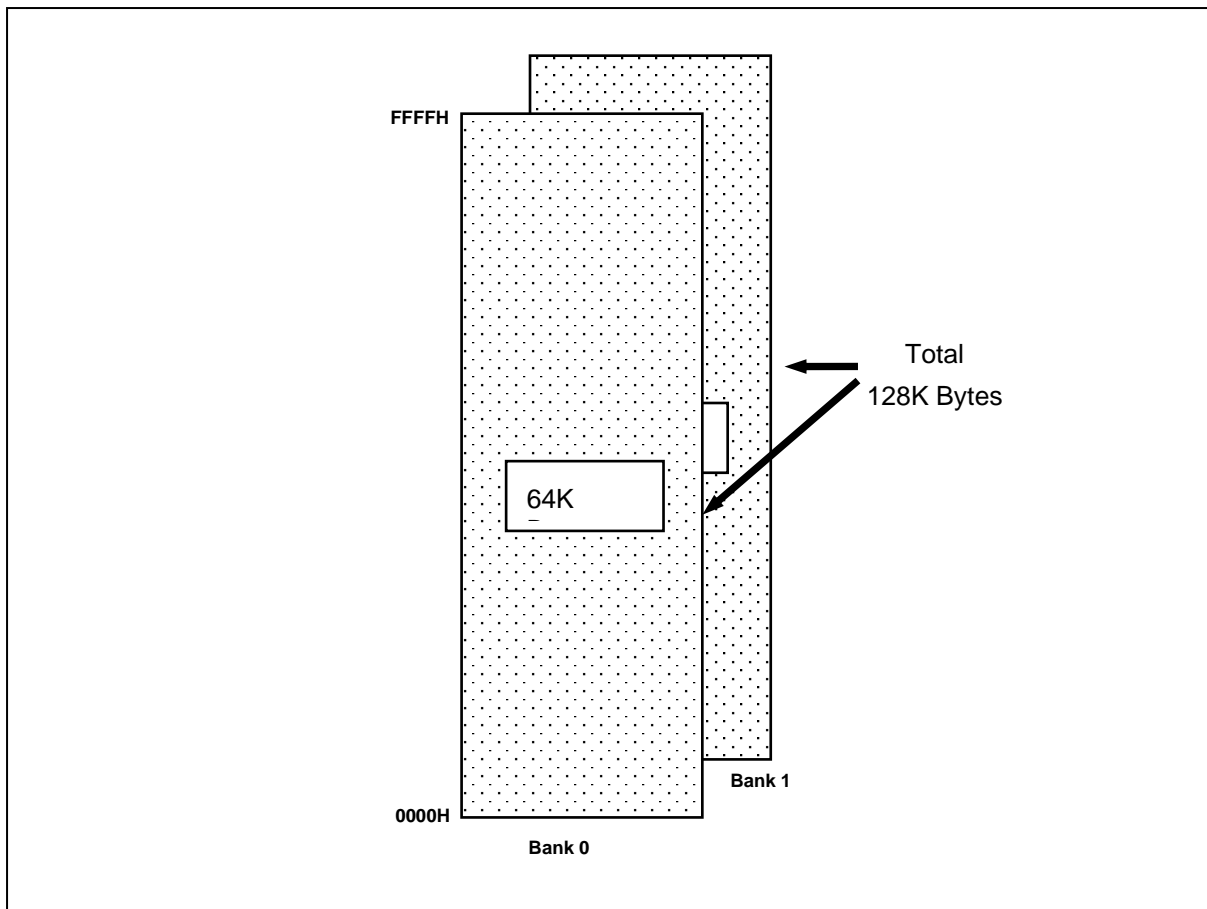
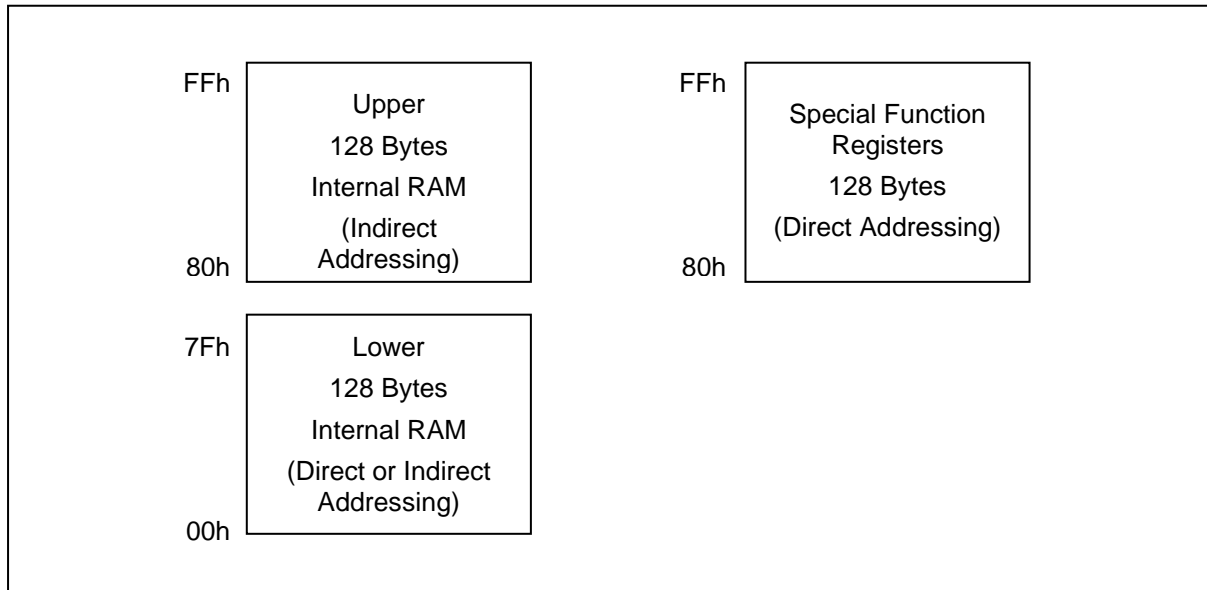

**Figure 8.1 Program memory**

- User Function Mode: 128KBytes Included Interrupt Vector Region
- Non-volatile and reprogramming memory: Flash memory based on EEPROM cell

## 8.2 Data Memory

Figure 8.2 shows the internal Data memory space available.



**Figure 8.2 Data memory map**

The internal memory space is divided into three blocks, which are generally referred to as the lower 128, upper 128, and SFR space.

Internal Data memory addresses are always one byte wide, which implies an address space of only 256 bytes. However, the addressing modes for internal RAM can in fact accommodate 384 bytes, using a simple trick. Direct addresses higher than 7FH access one memory space and indirect addresses higher than 7FH access a different memory space. Thus Figure 8.2 shows the upper 128 and SFR space occupying the same block of addresses, 80H through FFH, although they are physically separate entities.

The lower 128 bytes of RAM are present in all 8051 devices as mapped in Figure 8.3. The lowest 32 bytes are grouped into 4 banks of 8 registers. Program instructions call out these registers as R0 through R7. Two bits in the Program Status Word select which register bank is in use. This allows more efficient use of code space, since register instructions are shorter than instructions that use direct addressing.

The next 16 bytes above the register banks form a block of bit-addressable memory space. The 8051 instruction set includes a wide selection of single-bit instructions, and the 128 bits in this area can be directly addressed by these instructions. The bit addresses in this area are 00H through 7FH.

All of the bytes in the lower 128 can be accessed by either direct or indirect addressing. The upper 128 bytes RAM can only be accessed by indirect addressing. These spaces are used for user RAM and stack pointer.



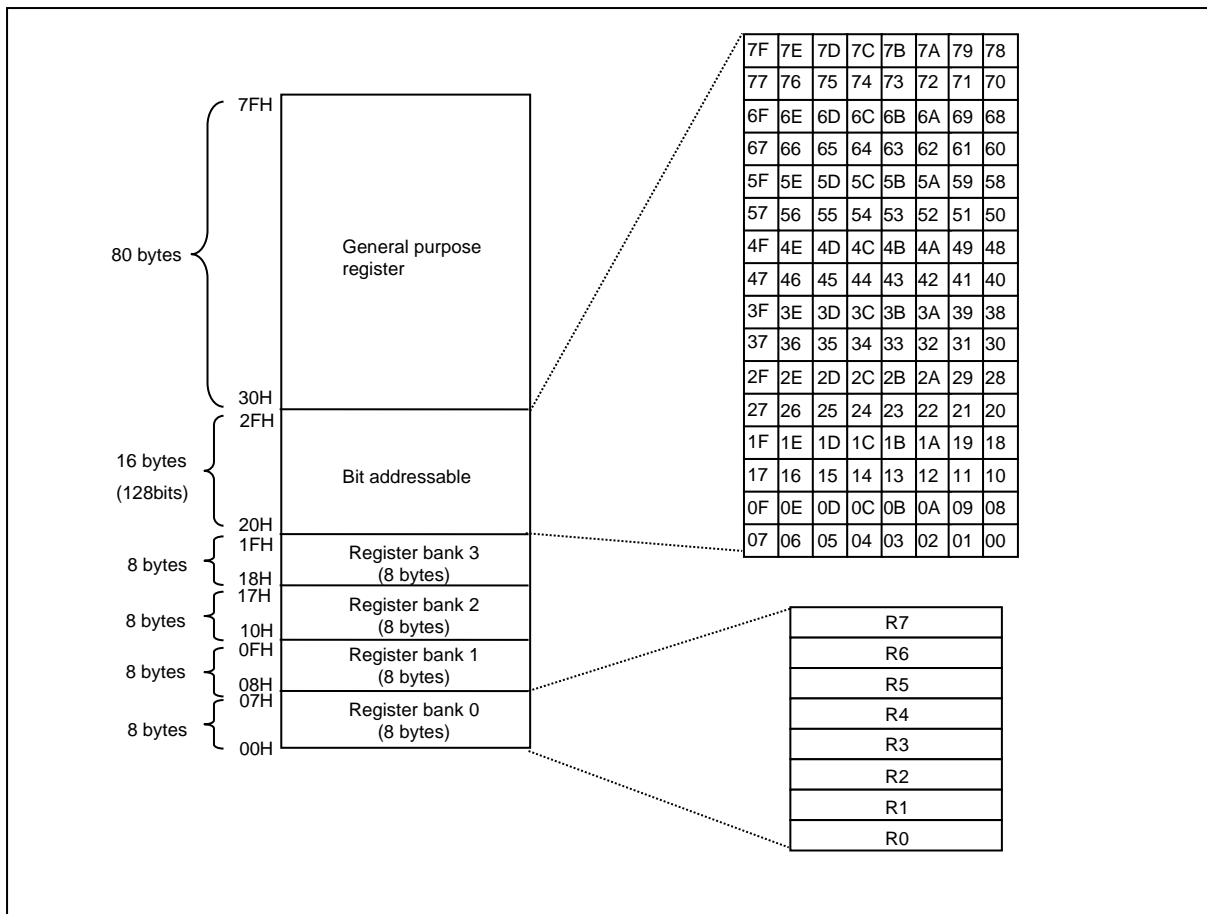

**Figure 8.3 Lower 128 bytes RAM**

### 8.3 EEPROM Data Memory and XSRAM

MC95FG0128A has 4K bytes EEPROM Data memory and 8K bytes of XSRAM. This area has no relation with RAM/FLASH. It can read and write through SFR with 8-bit unit.

For more information about EEPROM Data memory, see chapter 15.

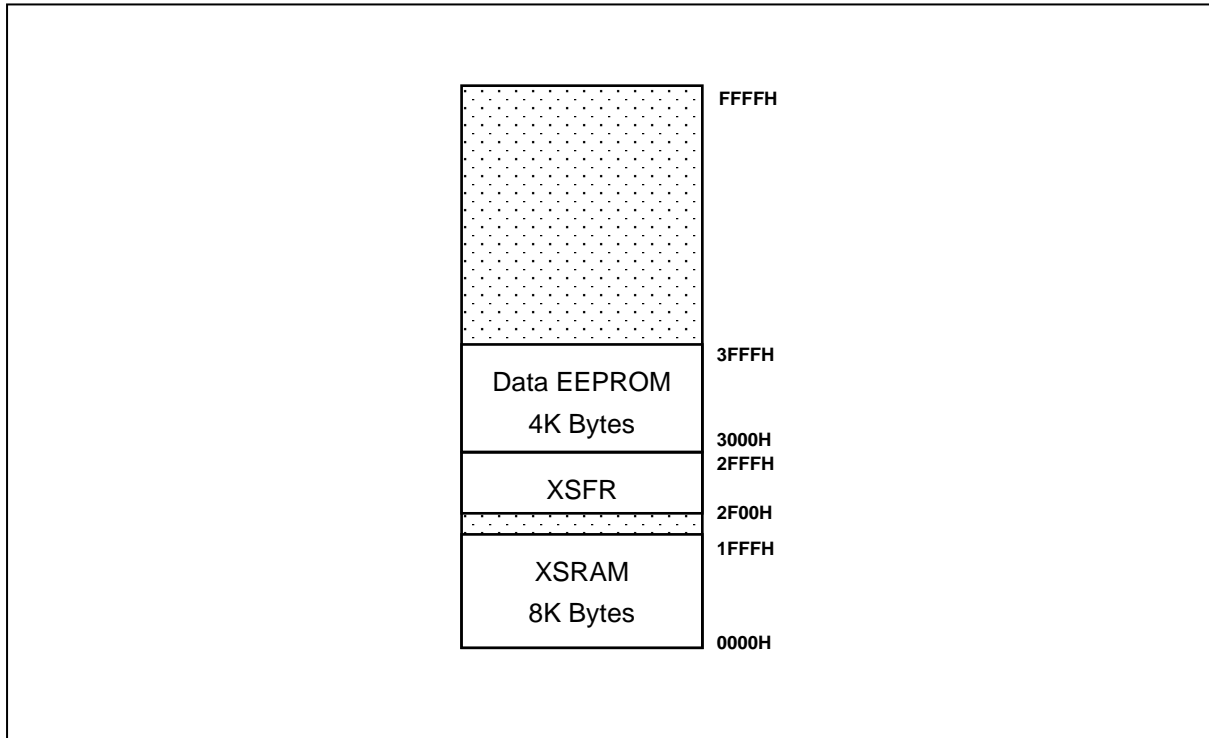

Figure 8.4 XDATA memory area

## 8.4 SFR Map

### 8.4.1 SFR Map Summary

Table 8-1 SFR Map Summary

	0H/8H	1H/9H	2H/AH	3H/BH	4H/CH	5H/DH	6H/EH	7H/FH
<b>2F58H</b>	-	FUSE_PKG	FUSE_CAL2	FUSE_CAL1	FUSE_CAL0	FUSE_CONF	TEST_B	TEST_A
<b>2F50H</b>	PSR0	PSR1	-	-	-	-	-	-
<b>2F48H</b>	-	-	-	-	-	-	-	-
<b>2F40H</b>	-	-	-	-	-	-	-	-
<b>2F38H</b>	T5CR	T5CR1	T5L	T5H	T5DRL	T5DRH	-	-
<b>2F30H</b>	UCTRL31	UCTRL32	UCTRL33	USTAT3	UBAUD3	UDATA3	-	-
<b>2F28H</b>	UCTRL21	UCTRL22	UCTRL23	USTAT2	UBAUD2	UDATA2	-	-
<b>2F20H</b>	P8DB	P9DB	PADB	-	-	-	-	-
<b>2F18H</b>	P0DB	P1DB	P2DB	P3DB	P4DB	P5DB	P6DB	P7DB
<b>2F10H</b>	P4OD	P5OD	P6OD	P7OD	P8OD	P9OD	PAOD	-
<b>2F08H</b>	P8PU	P9PU	PAPU	-	P0OD	P1OD	P2OD	P3OD
<b>2F00H</b>	P0PU	P1PU	P2PU	P3PU	P4PU	P5PU	P6PU	P7PU
<b>F8H</b>	IP1	-	UCTRL11	UCTRL12	UCTRL13	USTAT1	UBAUD1	UDATA1
<b>F0H</b>	B	SPIR1	FEARL	FEARM	FEARH	FEDR	FETR	XCON
<b>E8H</b>	P9	PAIO	FEMR	FECR	FESR	FETCR	XADD	XDATA
<b>E0H</b>	ACC	PA	UCTRL01	UCTRL02	UCTRL03	USTAT0	UBAUD0	UDATA0
<b>D8H</b>	P8	P9IO	I2CMR	I2CSR	I2CSCLLR	I2CSCLHR	I2CSDAHR	I2CDR
<b>D0H</b>	PSW	P8IO	SPICR0	SPIDR0	SPIR0	TMISR	I2CSAR1	I2CSAR
<b>C8H</b>	P7	P7IO	T4CR	T4CR1	T4L	T4H	T4DRL	T4DRH
<b>C0H</b>	P6	P6IO	T3CR	T3CR1	T3L	T3H	T3DRL	T3DRH
<b>B8H</b>	IP	P5IO	T2CR	T2CR1	T2L	T2H	T2DRL	T2DRH
<b>B0H</b>	P5	P4IO	T0CR	T0DR	T1CR	T1DR	T1PWDR	T1PWHR
<b>A8H</b>	IE	IE1	IE2	IE3	IE4	IE5	PCI0	PCI7
<b>A0H</b>	P4	P3IO	EO	EIENAB	EIFLAG	EIEDGE	EIPOLA	PLLCR
<b>98H</b>	P3	P2IO	ADCM	ADCRH	ADCRL	WTMR	WTR	BUZCR
<b>90H</b>	P2	P1IO	SPICR1	SPIDR1	MEX1	MEX2	MEX3	MEXSP
<b>88H</b>	P1	P0IO	SCCR	BCCR	BITR	WDTMR	WDTR	BUZDR
<b>80H</b>	P0	SP	DPL	DPH	-	-	BODR	PCON

### 8.4.2 Compiler Compatible SFR

#### ACC (Accumulator) : E0H

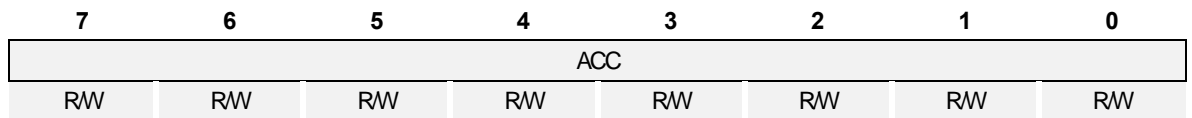

Initial value : 00H

**ACC**      Accumulator

#### B (B Register) : F0H

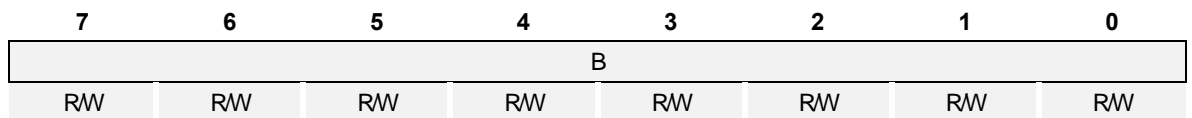

Initial value : 00H

**B**      B Register

#### SP (Stack Pointer) : 81H

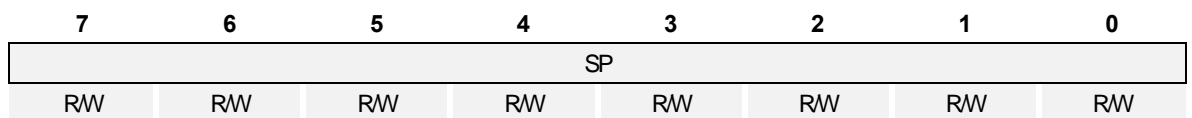

Initial value : 07H

**SP**      Stack Pointer

#### DPL (Data Pointer Low Byte) : 82H

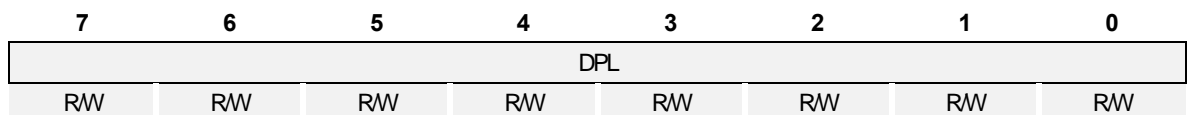

Initial value : 00H

**DPL**      Data Pointer Low Byte

#### DPH (Data Pointer High Byte) : 83H

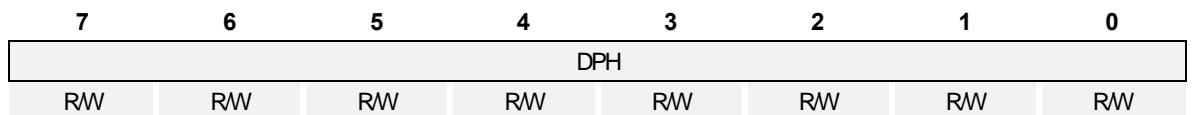

Initial value : 00H

**DPH**      Data Pointer High Byte

#### DPL1 (Data Pointer Low 1 Byte) : 84H

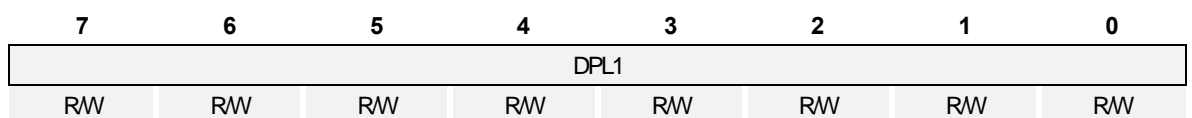

Initial value : 00H

**DPL1**      Data Pointer Low 1 Byte

**DPH1 (Data Pointer High 1 Byte) : 85H**

7	6	5	4	3	2	1	0
DPH1							
RW	RW	RW	RW	RW	RW	RW	RW

Initial value : 00H

**DPH1**      Data Pointer High 1 Byte

**PSW (Program Status Word) : D0H**

7	6	5	4	3	2	1	0
CY	AC	F0	RS1	RS0	OV	F1	P
RW	RW	RW	RW	RW	RW	RW	RW

Initial value : 00H

- CY**      Carry Flag
- AC**      Auxiliary Carry Flag
- F0**      General Purpose User-Definable Flag
- RS1**     Register Bank Select bit 1
- RS0**     Register Bank Select bit 0
- OV**      Overflow Flag
- F1**      User-Definable Flag
- P**        Parity Flag. Set/cleared by hardware each instruction cycle to indicate an odd/even number of '1' bits in the accumulator

**EO (Extended Operation Register) : A2H**

7	6	5	4	3	2	1	0
-	-	-	TRAP_EN	-	DPSEL2	DPSEL1	DPSEL0
R	R	R	RW	R	RW	RW	RW

Initial value : 00H

- TRAP\_EN**      Select the instruction
  - 0      Select MOVC @(DPTR++), A
  - 1      Select Software TRAP instruction
- DPSEL[2:0]**    Select Banked Data Point Register
 

DPSEL2	DPSEL1	DPSEL0	
0	0	0	DPTR0
0	0	1	DPTR1
0	1	0	DPTR2
0	1	1	DPTR3
1	0	0	DPTR4
1	0	1	DPTR5
1	1	0	DPTR6
1	1	1	DPTR7

**MEX1 (Memory Extension Register 1) : 94H**

7	6	5	4	3	2	1	0
CB19	CB18	CB17	CB16	NB19	NB18	NB17	NB16
R	R	R	R	R/W	R/W	R/W	R/W

Initial value : 00H

**CB[19:16]** Current Bank**NB[19:16]** Next Bank

note) This register records the 'current' and 'next' memory bank numbers for Program code.

**MEX2 (Memory Extension Register 2) : 95H**

7	6	5	4	3	2	1	0
MCM	MCB18	MCB17	MCB16	IB19	IB18	IB17	IB16
R/W	R/W	R/W	R/W	R/W	R/W	R/W	R/W

Initial value : 00H

**MCM** Memory Constant Mode . set to '1' when Memory Bank used.**MCB[18:16]** Memory Constant Bank ( with MEX3.7)**IB[19:16]** Interrupt Bank

Note) This register controls the current memory bank numbers for interrupt service routine code and for memory constants.

**MEX3 (Memory Extension Register 3) : 96H**

7	6	5	4	3	2	1	0
MCB19	UB1	UB0	MXB19	MXM	MXB18	MXB17	MXB16
R/W	R/W	R/W	R/W	R/W	R/W	R/W	R/W

Initial value : 00H

**MCB19** Memory Constant Bank MSB. See MEX2**UB[1:0]** Bits available to the user**MXM** XRAM Bank selector. When set to '1', the MOVX Bank bits MX19-MX16 are used as XRAMA19-16 instead of the Current Bank (CB)**MXB[18:16]** XRAM Bank

Note) This register chiefly controls the current memory bank number for external data memory.

**MEXSP (Memory Extension Stack Pointer) : 97H**

7	6	5	4	3	2	1	0
-	MEXSP6	MEXSP5	MEXSP4	MEXSP3	MEXSP2	MEXSP1	MEXSP0
R/W	R/W	R/W	R/W	R/W	R/W	R/W	R/W

Initial value : 7FH

**MEXSP[6:0]** Memory Extension Stack Pointer

Note) This register is the Memory Extension Stack Pointer. It provides for a stack depth of up to 128 bytes (Bit 7 is always 0). It is pre-incremented by call instructions and post-decremented by return instructions.

## 9. I/O Ports

### 9.1 I/O Ports

The MC95FG0128A has eleven I/O ports (P0 ~ PA). Each port can be easily configured by software as I/O pin, internal pull up and open drain pin to meet various system configurations and design requirements. Also P0, P7 include function that can generate interrupt according to change of state of the pin.

### 9.2 Port Register

#### 9.2.1 Data Register (Px)

Data Register is a bidirectional I/O port. If ports are configured as output ports, data can be written to the corresponding bit of the Px. If ports are configured as input ports, the data can be read from the corresponding bit of the Px.

Note) Do not use the “direct bit test and branch” instruction for input port, more detail information is at Appendix D.

(example) avoid direct input port bit test and branch condition as below  
 $\text{if}(P00) \rightarrow \text{if}(P0 \ \& \ 0x01)$

#### 9.2.2 Direction Register (PxIO)

Each I/O pin can independently used as an input or an output through the PxIO register. Bits cleared in this read/write register will select the corresponding pin in Px to become an input, setting a bit sets the pin to output. All bits are cleared by a system reset.

#### 9.2.3 Pull-up Resistor Selection Register (PxPU)

The on-chip pull-up resistor can be connected to them in 1-bit units with a pull-up resistor selection register (PxPU). The pull-up register selection controls the pull-up resistor enable/disable of each port. When the corresponding bit is 1, the pull-up resistor of the pin is enabled. When 0, the pull-up resistor is disabled. All bits are cleared by a system reset.

#### 9.2.4 Open-drain Selection Register (PxOD)

There is internally open-drain selection register (PxOD) in P0 ~ PA. The open-drain selection register controls the open-drain enable/disable of each port. Ports become push-pull by a system reset. You should connect an internal resistor or an external resistor in open-drain output mode.

#### 9.2.5 Debounce Enable Register (PxDB)

P0 ~ PA support debounce function. Debounce time of each ports has 5us

### 9.2.6 Pin Change Interrupt Enable Register (PCIx)

The P0, P7 can support Pin Change Interrupt function. Pin Change Interrupts PCI will trigger if any enabled P0[7:0], P7[7:0] pin toggles. The PCIx Register control which pins contribute to the pin change interrupts.

### 9.2.7 Port Selection Register (PSRx)

PSRx registers prevent the input leakage current when ports are connected to analog inputs. If the bit of PSRx is '1', the dynamic current path of the schmitt OR gate of the port is cut off and the digital input of the corresponding port is always '0'.

### 9.2.8 Register Map

Table 9-1 Register Map

Name	Address	Dir	Default	Description
P0	80H	R/W	00H	P0 Data Register
P0IO	89H	R/W	00H	P0 Direction Register
P0PU	2F00H	R/W	00H	P0 Pull-up Resistor Selection Register
P0OD	2F0CH	R/W	00H	P0 Open-drain Selection Register
P0DB	2F18H	R/W	00H	P0 Debounce Enable Register
PCI0	AEH	R/W	00H	P0 Pin Change Interrupt Enable Register
P1	88H	R/W	00H	P1 Data Register
P1IO	91H	R/W	00H	P1 Direction Register
P1PU	2F01H	R/W	00H	P1 Pull-up Resistor Selection Register
P1OD	2F0DH	R/W	00H	P1 Open-drain Selection Register
P1DB	2F19H	R/W	00H	P1 Debounce Enable Register
P2	90H	R/W	00H	P2 Data Register
P2IO	99H	R/W	00H	P2 Direction Register
P2PU	2F02H	R/W	00H	P2 Pull-up Resistor Selection Register
P2OD	2F0EH	R/W	00H	P2 Open-drain Selection Register
P2DB	2F1AH	R/W	00H	P2 Debounce Enable Register
P3	98H	R/W	00H	P3 Data Register
P3IO	A1H	R/W	00H	P3 Direction Register
P3PU	2F03H	R/W	00H	P3 Pull-up Resistor Selection Register
P3OD	2F0FH	R/W	00H	P3 Open-drain Selection Register
P3DB	2F1BH	R/W	00H	P3 Debounce Enable Register
P4	A0H	R/W	00H	P4 Data Register
P4IO	B1H	R/W	00H	P4 Direction Register
P4PU	2F04H	R/W	00H	P4 Pull-up Resistor Selection Register
P4OD	2F10H	R/W	00H	P4 Open-drain Selection Register
P4DB	2F1CH	R/W	00H	P4 Debounce Enable Register
P5	B0H	R/W	00H	P5 Data Register



P5IO	B9H	R/W	00H	P5 Direction Register
P5PU	2F05H	R/W	00H	P5 Pull-up Resistor Selection Register
P5OD	2F11H	R/W	00H	P5 Open-drain Selection Register
P5DB	2F1DH	R/W	00H	P5 Debounce Enable Register
P6	C0H	R/W	00H	P6 Data Register
P6IO	C1H	R/W	00H	P6 Direction Register
P6PU	2F06H	R/W	00H	P6 Pull-up Resistor Selection Register
P6OD	2F12H	R/W	00H	P6 Open-drain Selection Register
P6DB	2F1EH	R/W	00H	P6 Debounce Enable Register
P7	C8H	R/W	00H	P7 Data Register
P7IO	C9H	R/W	00H	P7 Direction Register
P7PU	2F07H	R/W	00H	P7 Pull-up Resistor Selection Register
P7OD	2F13H	R/W	00H	P7 Open-drain Selection Register
P7DB	2F1FH	R/W	00H	P7 Debounce Enable Register
PCI7	AFH	R/W	00H	P7 Pin Change Interrupt Enable Register
P8	D8H	R/W	00H	P8 Data Register
P8IO	D1H	R/W	00H	P8 Direction Register
P8PU	2F08H	R/W	00H	P8 Pull-up Resistor Selection Register
P8OD	2F14H	R/W	00H	P8 Open-drain Selection Register
P8DB	2F20H	R/W	00H	P8 Debounce Enable Register
P9	E8H	R/W	00H	P9 Data Register
P9IO	D9H	R/W	00H	P9 Direction Register
P9PU	2F09H	R/W	00H	P9 Pull-up Resistor Selection Register
P9OD	2F15H	R/W	00H	P9 Open-drain Selection Register
P9DB	2F21H	R/W	00H	P9 Debounce Enable Register
PA	E1H	R/W	00H	PA Data Register
PAIO	E9H	R/W	00H	PA Direction Register
PAPU	2F0AH	R/W	00H	PA Pull-up Resistor Selection Register
PAOD	2F16H	R/W	00H	PA Open-drain Selection Register
PADB	2F22H	R/W	00H	PA Debounce Enable Register
PSR0	2F50H	R/W	00H	Port Selection Register 0
PSR1	2F51H	R/W	00H	Port Selection Register 1

## 9.3 Px Port

### 9.3.1 Px Port Description

Px is 8-bit I/O port. Px control registers consist of Data register (Px), direction register (PxIO), debounce enable register (PxDB), pull-up register selection register (PxPU), open-drain selection register (PxOD), pin change interrupt register (PCI0, PCI7)

### 9.3.2 Register description for Px

**Px (Px Data Register) : 80H, 88H, 90H, 98H, A0H, B0H, C0H, C8H, D8H, E8H, E1H**

7	6	5	4	3	2	1	0
Px7	Px6	Px5	Px4	Px3	Px2	Px1	Px0
RW	RW	RW	RW	RW	RW	RW	RW

Initial value : 00H

**Px[7:0]** I/O Data

**PxIO (Px Direction Register) : 89H, 91H, 99H, A1H, B1H, B9H, C1H, C9H, D1H, D9H, E9H**

7	6	5	4	3	2	1	0
Px7IO	Px6IO	Px5IO	Px4IO	Px3IO	Px2IO	Px1IO	Px0IO
RW	RW	RW	RW	RW	RW	RW	RW

Initial value : 00H

**PxIO[7:0]** Px data I/O direction.  
 0 Input  
 1 Output

**PxPU (Px Pull-up Resistor Selection Register) : 2F00H ~ 2F0AH**

7	6	5	4	3	2	1	0
Px7PU	Px6PU	Px5PU	Px4PU	Px3PU	Px2PU	Px1PU	Px0PU
RW	RW	RW	RW	RW	RW	RW	RW

Initial value : 00H

**PxPU[7:0]** Configure pull-up resistor of Px port  
 0 Disable  
 1 Enable

**PxOD (Px Open-drain Selection Register) : 2F0CH ~ 2F16H**

7	6	5	4	3	2	1	0
Px7OD	Px6OD	Px5OD	Px4OD	Px3OD	Px2OD	Px1OD	Px0OD
RW	RW	RW	RW	RW	RW	RW	RW

Initial value : 00H

**PxOD[7:0]** Configure open-drain of Px port  
 0 Disable  
 1 Enable

**PxDB (Px Debounce Enable Register) : 2F18H ~ 2F22H**

7	6	5	4	3	2	1	0
Px7DB	Px6DB	Px5DB	Px4DB	Px3DB	Px2DB	Px1DB	Px0DB
R/W	R/W	R/W	R/W	R/W	R/W	R/W	R/W

Initial value : 00H

**PxDB[7:0]** Configure debounce of Px port  
 0 Disable  
 1 Enable

**PCI0 (P0 Pin Change Interrupt Enable Register) : AEH**

7	6	5	4	3	2	1	0
PCI07	PCI06	PCI05	PCI04	PCI03	PCI02	PCI01	PCI00
R/W	R/W	R/W	R/W	R/W	R/W	R/W	R/W

Initial value : 00H

**PCI0[7:0]** Configure Pin Change Interrupt of P0 port  
 0 Disable  
 1 Enable

**PCI7 (P7 Pin Change Interrupt Enable Register) : AFH**

7	6	5	4	3	2	1	0
PCI77	PCI76	PCI75	PCI74	PCI73	PCI72	PCI71	PCI70
R/W	R/W	R/W	R/W	R/W	R/W	R/W	R/W

Initial value : 00H

**PCI7[7:0]** Configure Pin Change Interrupt of P7port  
 0 Disable  
 1 Enable

**PSR0 (Port Selection Register 0) : 50H**

7	6	5	4	3	2	1	0
PSR07	PSR06	PSR05	PSR04	PSR03	PSR02	PSR01	PSR00
R/W	R/W	R/W	R/W	R/W	R/W	R/W	R/W

Initial value : 00H

**PSR0[7:0]** P20~P27 port selection register  
 0 Disable analog channel AN[7:0].  
 1 Enable analog channel AN[7:0].

**PSR1 (Port Selection Register 1) : 51H**

7	6	5	4	3	2	1	0
-	PSR16	PSR15	PSR14	PSR13	PSR12	PSR11	PSR10
-	R/W	R/W	R/W	R/W	R/W	R/W	R/W

Initial value : 00H

**PSR1[6:0]** P30~P36 port selection register  
 0 Disable analog channel AN[14:8].  
 1 Enable analog channel AN[14:8].

## 10. Interrupt Controller

### 10.1 Overview

The MC95FG0128A supports up to 32 interrupt sources. The interrupts have separate enable register bits associated with them, allowing software control. They can also have four levels of priority assigned to them. The interrupt controller has following features:

- receive the request from 32 interrupt source
- 8 group priority
- 4 priority levels
- Multi Interrupt possibility
- If the requests of different priority levels are received simultaneously, the request of higher priority level is serviced
- Each interrupt source can control by EA bit and each IEx bit
- Interrupt latency: 5–8 machine cycles in single interrupt system

The maskable interrupts are enabled through five pair of interrupt enable registers (IE, IE1, IE2, IE3, IE4, IE5). Bits of IE, IE1, IE2, IE3, IE4, IE5 register each individually enable/disable a particular interrupt source. Overall control is provided by bit 7 of IE (EA). When EA is set to '0', all interrupts are disabled; when EA is set to '1', interrupts are individually enabled or disabled through the other bits of the interrupt enable registers. The MC95FG0128A supports a four-level priority scheme. Each maskable interrupt is individually assigned to one of four priority levels by writing to IP or IP1.

Interrupt default mode is level-trigger basically but if needed, it is able to change edge-trigger mode. Table 10-1 shows the Interrupt Group Priority Level that is available for sharing interrupt priority. Priority sets two bit which is to IP and IP1 register about group. Interrupt service routine services higher priority. If two requests of different priority levels are received simultaneously, the request of higher priority level is serviced. If the request of same or lower priority level is received, that request is not serviced.

**Table 10-1 Interrupt Group Priority Level**

Interrupt Group	Highest → Lowest			
	0 (Bit0)	Interrupt0	Interrupt8	Interrupt16
1 (Bit1)	Interrupt1	Interrupt9	Interrupt17	Interrupt25
2 (Bit2)	Interrupt2	Interrupt10	Interrupt18	Interrupt26
3 (Bit3)	Interrupt3	Interrupt11	Interrupt19	Interrupt27
4 (Bit4)	Interrupt4	Interrupt12	Interrupt20	Interrupt28
5 (Bit5)	Interrupt5	Interrupt13	Interrupt21	Interrupt29
6 (Bit6)	Interrupt6	Interrupt14	Interrupt22	Interrupt30
7 (Bit7)	Interrupt7	Interrupt15	Interrupt23	Interrupt31

Highest  
↓  
Lowest

### 10.2 External Interrupt

The external interrupt on INT0, INT1, INT2, INT3, INT4, INT5, INT6 and INT7 pins receive various

interrupt request depending on the edge selection register EIEDGE (External Interrupt Edge register) and EIPOLA (External Interrupt Polarity register) as shown in Figure 10.1. Also each external interrupt source has control setting bits. The EIFLAG (External interrupt flag register) register provides the status of external interrupts.

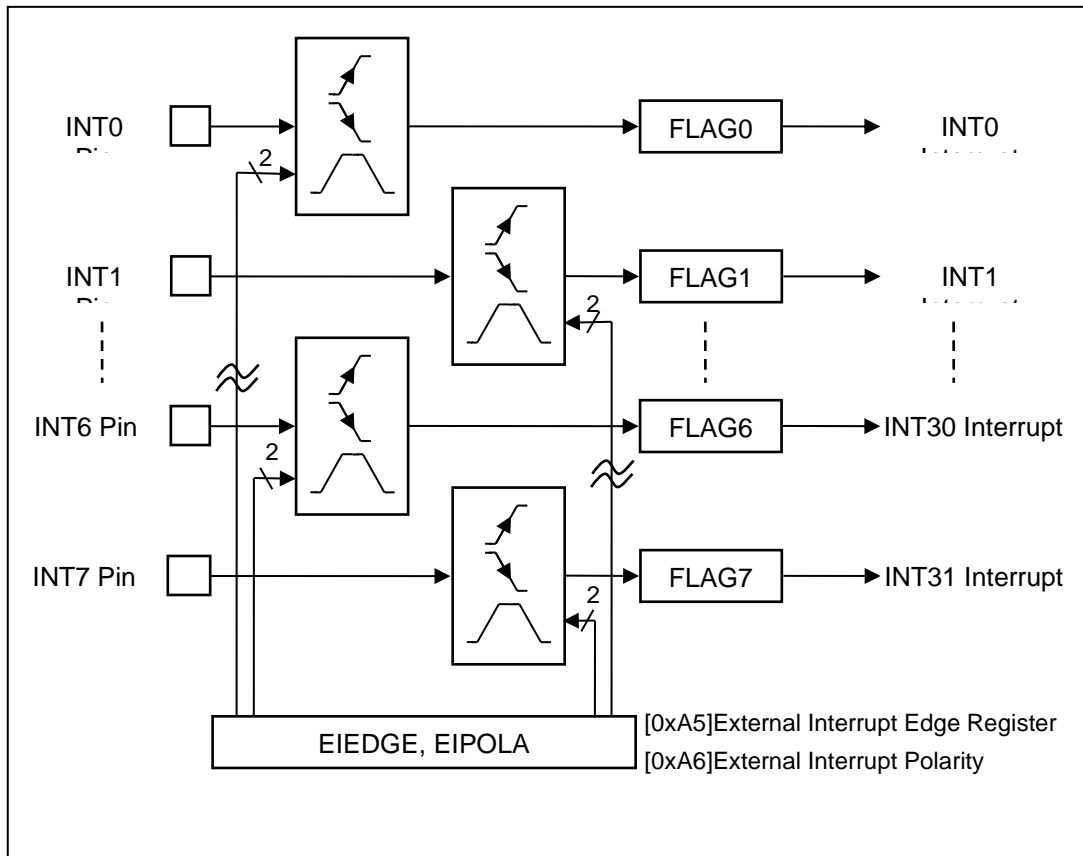

**Figure 10.1 External Interrupt Description**

10.3 Block Diagram

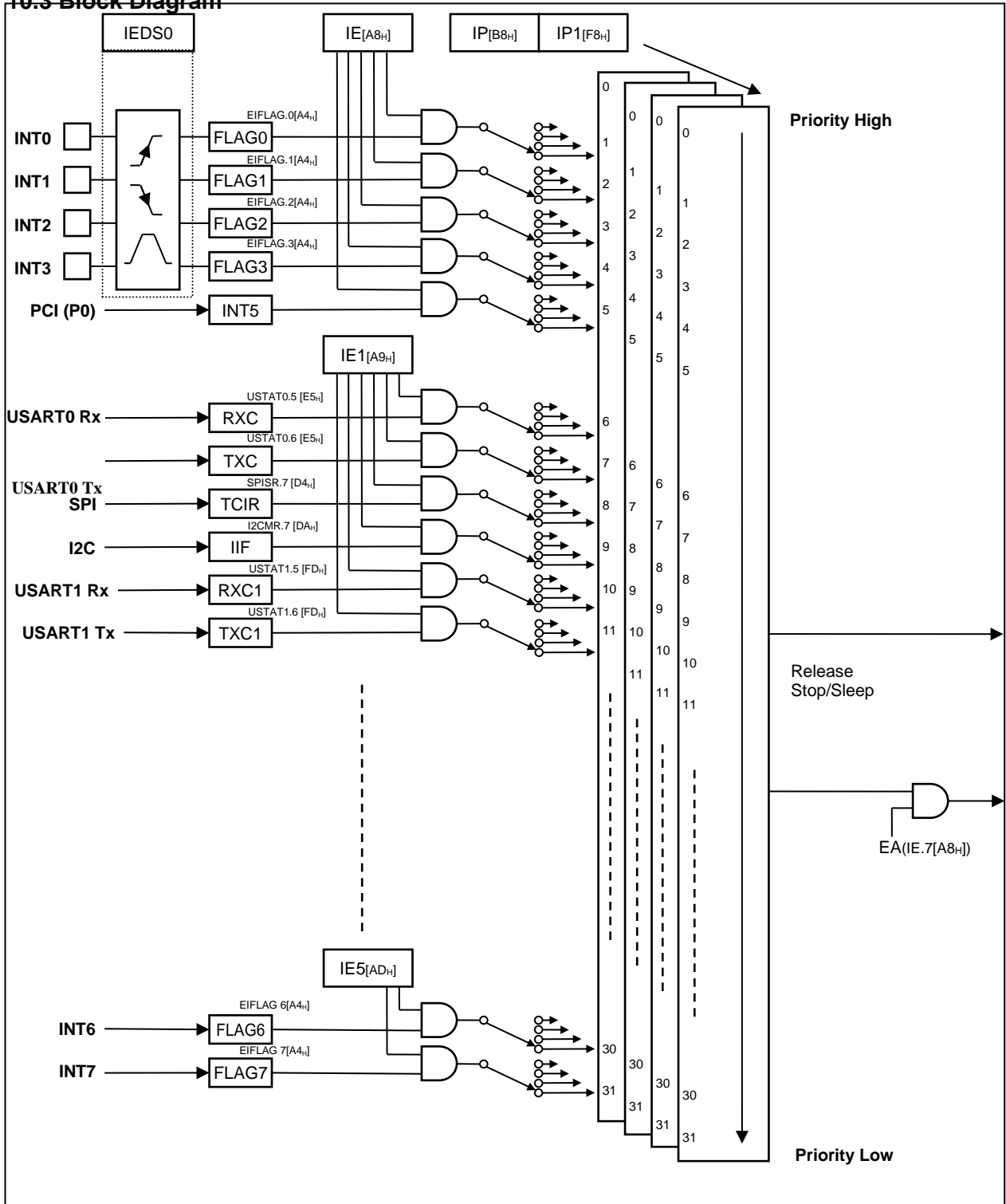

Figure 10.2 Block Diagram of Interrupt

## 10.4 Interrupt Vector Table

The interrupt controller supports 32 interrupt sources as shown in the Table 10-2 below. When interrupt becomes service, long call instruction (LCALL) is executed in the vector address. Interrupt request 32 has a decided priority order.

**Table 10-2 Interrupt Vector Address Table**

Interrupt Source	Symbol	Interrupt Enable Bit	Priority	Mask	Vector Address
Hardware Reset	RESETB	0	0	Non-Maskable	0000H
External Interrupt 0	INT0	IE0.0	1	Maskable	0003H
External Interrupt 1	INT1	IE0.1	2	Maskable	000BH
External Interrupt 2	INT2	IE0.2	3	Maskable	0013H
External Interrupt 3	INT3	IE0.3	4	Maskable	001BH
Pin Change Interrupt (P0)	INT4	IE0.4	5	Maskable	0023H
Pin Change Interrupt (P7)	INT5	IE0.5	6	Maskable	002BH
USART0 Rx	INT6	IE1.0	7	Maskable	0033H
USART0Tx	INT7	IE1.1	8	Maskable	003BH
SPI0	INT8	IE1.2	9	Maskable	0043H
I <sup>2</sup> C	INT9	IE1.3	10	Maskable	004BH
USART1 Rx	INT10	IE1.4	11	Maskable	0053H
USART1 Tx	INT11	IE1.5	12	Maskable	005BH
T0	INT12	IE2.0	13	Maskable	0063H
T1	INT13	IE2.1	14	Maskable	006BH
T2	INT14	IE2.2	15	Maskable	0073H
T3	INT15	IE2.3	16	Maskable	007BH
T4	INT16	IE2.4	17	Maskable	0083H
T5	INT17	IE2.5	18	Maskable	008BH
ADC	INT18	IE3.0	19	Maskable	0093H
EEPROM	INT19	IE3.1	20	Maskable	009BH
WT	INT20	IE3.2	21	Maskable	00A3H
WDT	INT21	IE3.3	22	Maskable	00ABH
BIT	INT22	IE3.4	23	Maskable	00B3H
SPI1	INT23	IE3.5	24	Maskable	00BBH
USART2 Rx	INT24	IE4.0	25	Maskable	00C3H
USART2 Tx	INT25	IE4.1	26	Maskable	00CBH
USART3 Rx	INT26	IE4.2	27	Maskable	00D3H
USART3 Tx	INT27	IE4.3	28	Maskable	00DBH
External Interrupt 4	INT28	IE4.4	29	Maskable	00E3H
External Interrupt 5	INT29	IE4.5	30	Maskable	00EBH
External Interrupt 6	INT30	IE5.0	31	Maskable	00F3H
External Interrupt 7	INT31	IE5.1	32	Maskable	00FBH

For maskable interrupt execution, first EA bit must set '1' and specific interrupt source must set '1' by writing a '1' to associated bit in the IEx. If interrupt request is received, specific interrupt request flag set '1'. And it remains '1' until CPU accepts interrupt. After that, interrupt request flag will be cleared automatically.

## 10.5 Interrupt Sequence

An interrupt request is held until the interrupt is accepted or the interrupt latch is cleared to '0' by a reset or an instruction. Interrupt acceptance always generates at last cycle of the instruction. So instead of fetching the current instruction, CPU executes internally LCALL instruction and saves the PC stack. For the interrupt service routine, the interrupt controller gives the address of LJMP instruction to CPU. After finishing the current instruction, at the next instruction to go interrupt service routine needs 5~8 machine cycle and the interrupt service task is terminated upon execution of an interrupt return

instruction [RETI]. After generating interrupt, to go to interrupt service routine, the following process is progressed

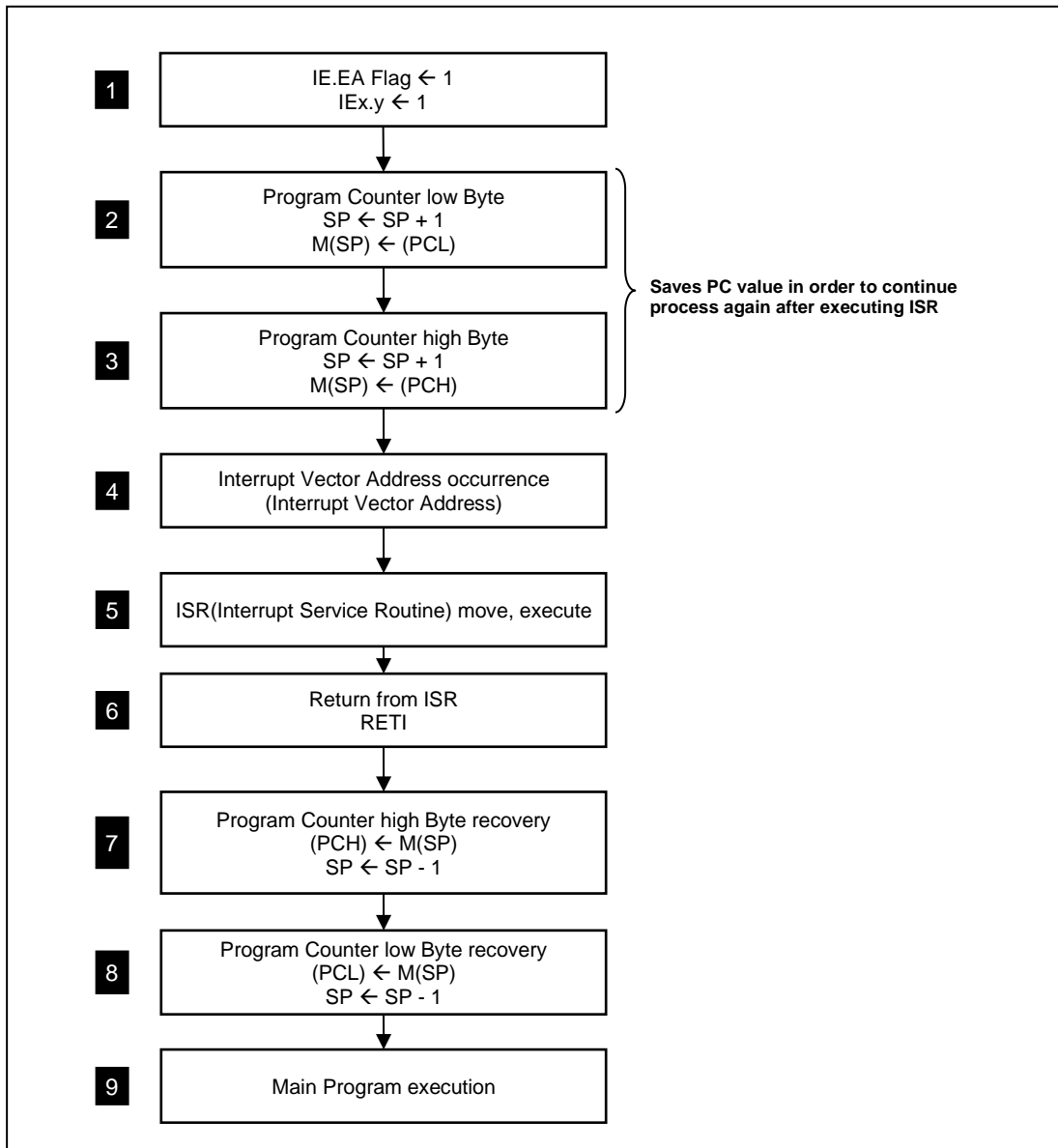
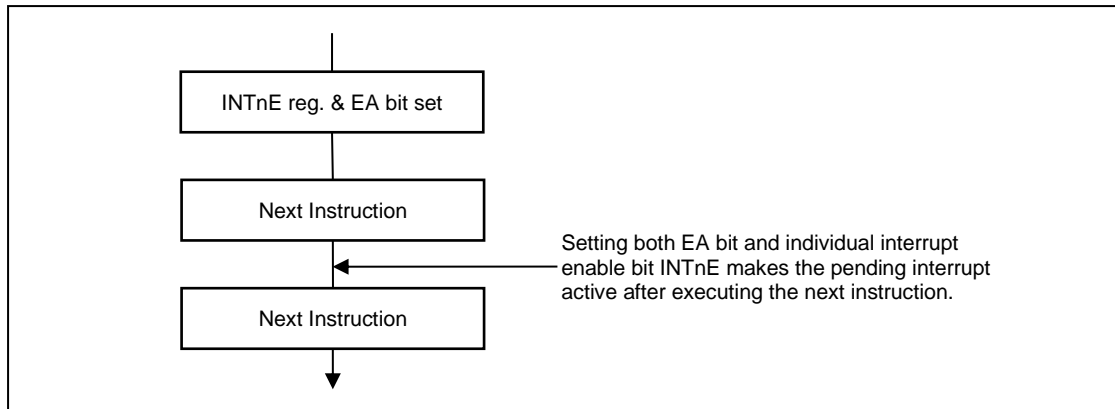

Figure 10.3 Interrupt Sequence Flow



### 10.6 Effective Timing after Controlling Interrupt bit



**Figure 10.4 Interrupt Enable Register effective Timing**

## 10.7 Multi Interrupt

If two requests of different priority levels are received simultaneously, the request of higher priority level is serviced. If requests of the interrupt are received at the same time simultaneously, an interrupt polling sequence determines by hardware which request is serviced. However, multiple processing through software for special features is possible.

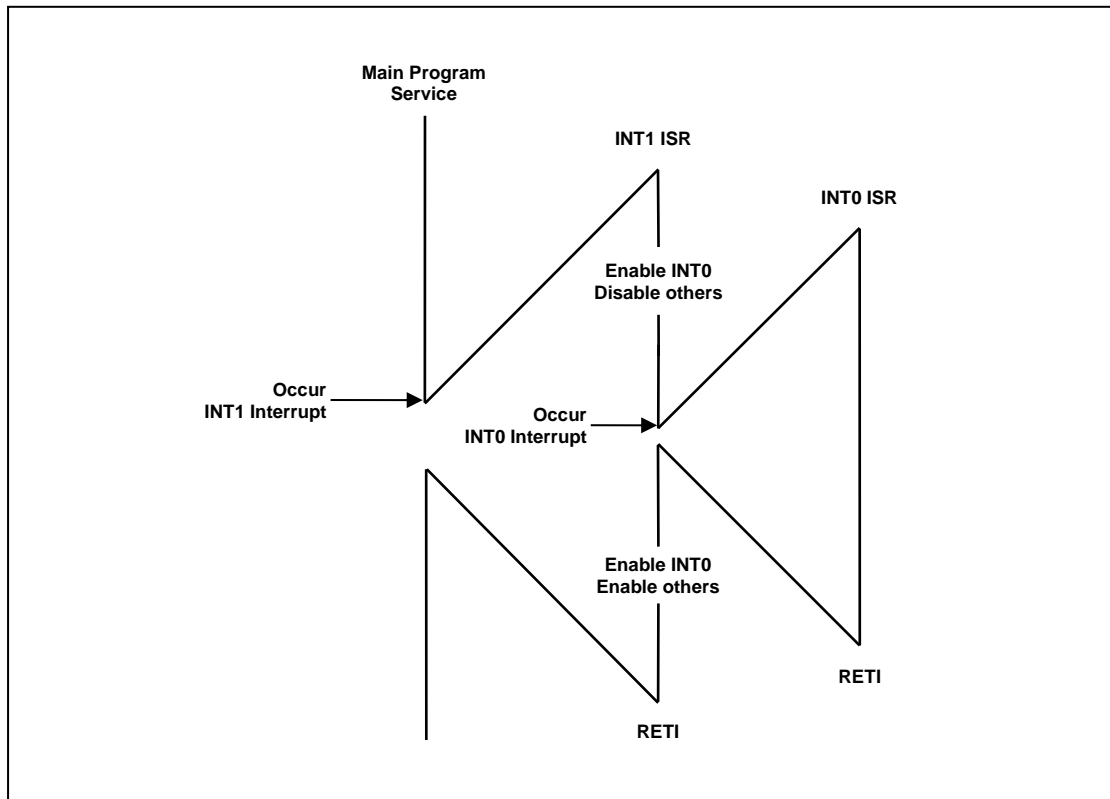

Figure 10.5 Execution of Multi Interrupt

Following example is shown to service INT0 routine during INT1 routine in Figure 10.6. In this example, INT0 interrupt priority is higher than INT1 interrupt priority. If some interrupt is lower than INT1 priority, it can't service its interrupt routine.

Example) Software Multi Interrupt:

```

INT1:  MOV    IE, #01H    ; Enable INT0 only
        MOV    IE1, #00H ; Disable others
        :
        MOV    IE, #0FFH ; Enable all Interrupts
        MOV    IE1, #0FFH
        RETI

```

### 10.8 Interrupt Enable Accept Timing

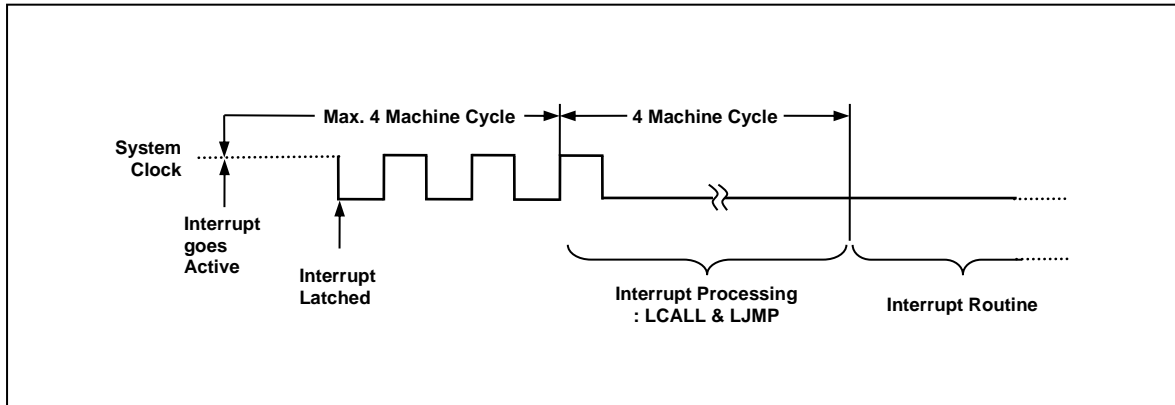

Figure 10.6 Interrupt Response Timing Diagram

### 10.9 Interrupt Service Routine Address

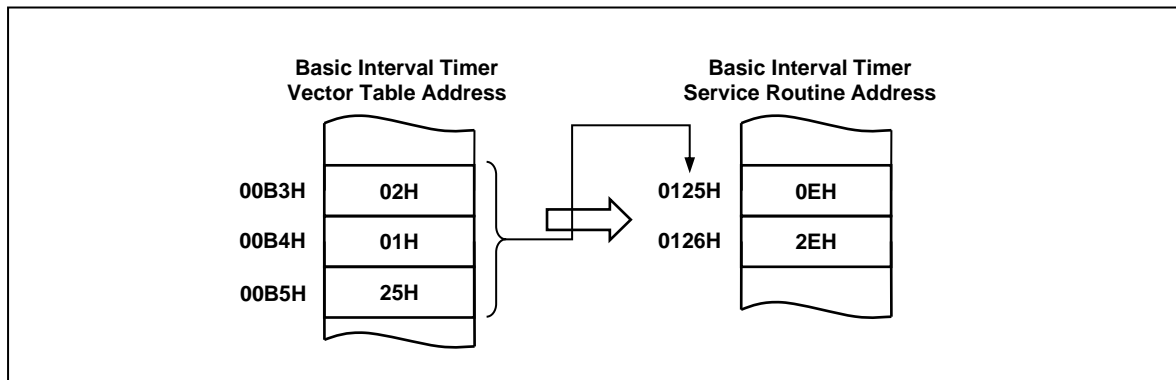

Figure 10.7 Correspondence between vector Table address and the entry address of ISR

### 10.10 Saving/Restore General-Purpose Registers

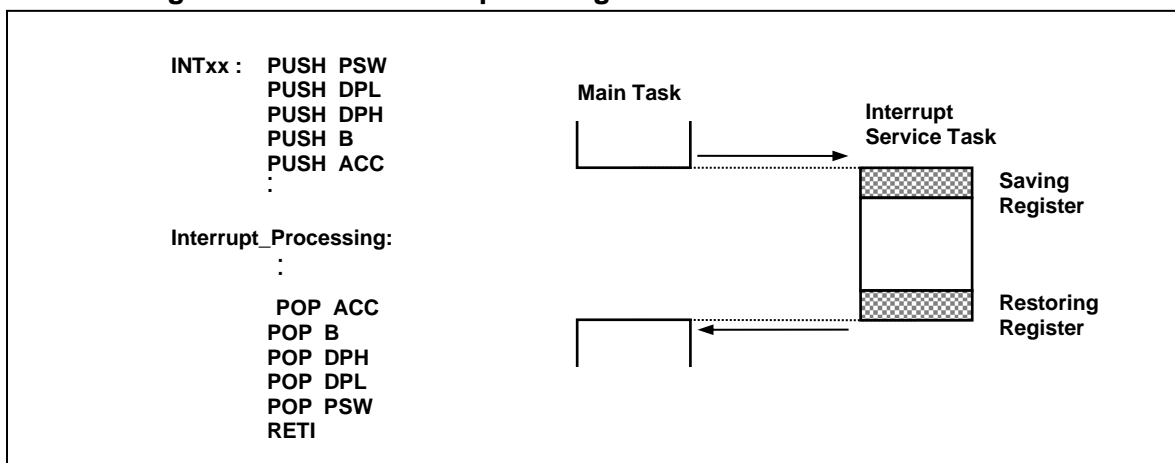

Figure 10.8 Saving/Restore Process Diagram & Sample Source

### 10.11 Interrupt Timing

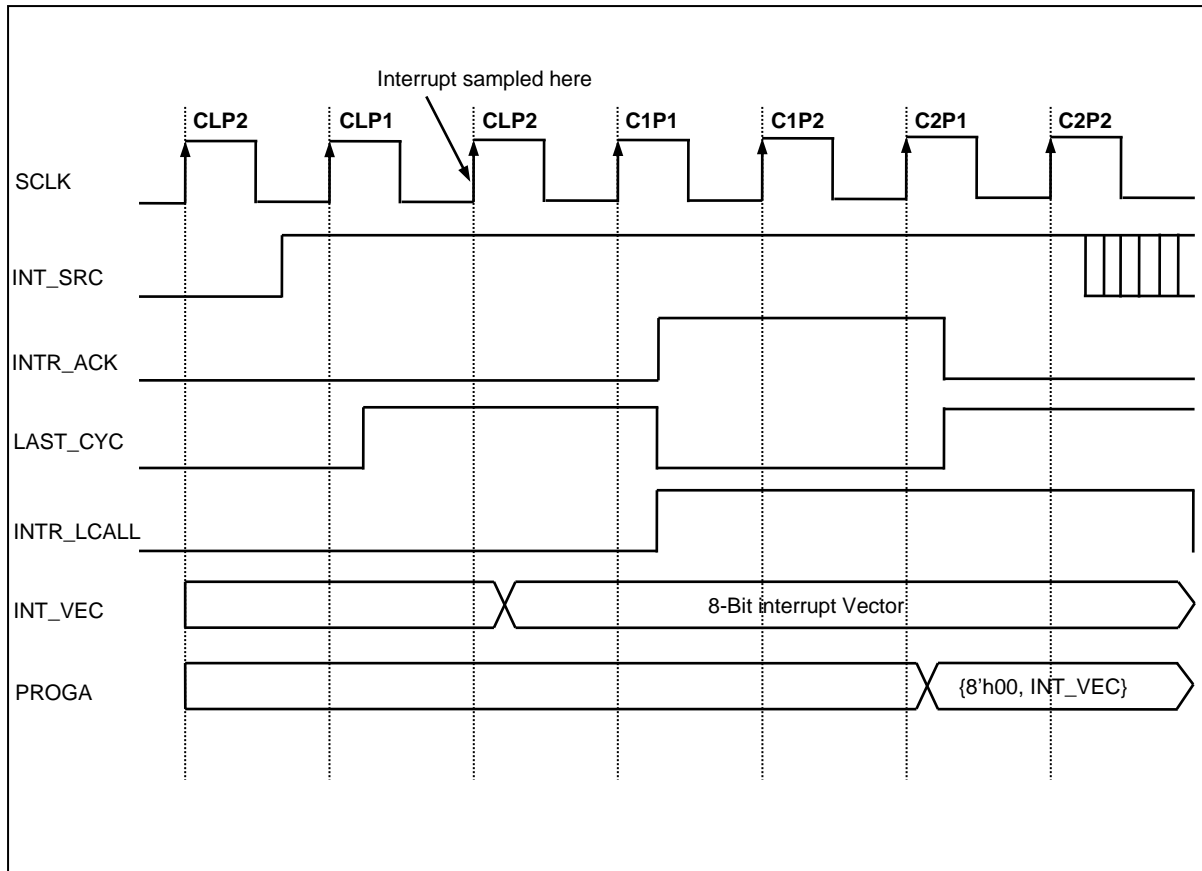

Figure 10.9 Timing chart of Interrupt Acceptance and Interrupt Return Instruction

Interrupt source sampled at last cycle of the command. When sampling interrupt source, it is decided to low 8-bit of interrupt vector. M8051W core makes interrupt acknowledge at first cycle of command, executes long call to jump interrupt routine as INT\_VEC.

Note) command cycle C?P?: L=Last cycle, 1=1<sup>st</sup> cycle or 1<sup>st</sup> phase, 2=2<sup>nd</sup> cycle or 2<sup>nd</sup> phase

### 10.12 Interrupt Register Overview

#### 10.12.1 Interrupt Enable Register (IE, IE1, IE2, IE3, IE4, IE5)

Interrupt enable register consists of Global interrupt control bit (EA) and peripheral interrupt control bits. Totally 32 peripheral are able to control interrupt.

#### 10.12.2 Interrupt Priority Register (IP, IP1)

The 32 interrupt divides 8 groups which have each 4 interrupt sources. A group can decide 4 levels interrupt priority using interrupt priority register. Level 3 is the high priority, while level 0 is the low priority. Initially, IP, IP1 reset value is '0'. At that initialization, low interrupt number has a higher priority than

high interrupt number. If decided the priority, low interrupt number has a higher priority than high interrupt number in that group.

### 10.12.3 External Interrupt Flag Register (EIFLAG)

The external interrupt flag register is set to '1' when the external interrupt generating condition is satisfied. The flag is cleared when the interrupt routine is executed. Alternatively, the flag can be cleared by writing a '0' to it.

### 10.12.4 External Interrupt Edge Register (EIEDGE)

The External interrupt edge register determines which type of edge or level sensitive interrupt. Initially, default value is level. For level, write '0' to related bit. For edge, write '1' to related bit.

### 10.12.5 External Interrupt Polarity Register (EIPOLA)

According to EIEDGE register, the external interrupt polarity (EIPOLA) register has a different meaning. If EIEDGE is level type, EIPOLA is able to have Low/High level value. If EIEGDE is edge type, EIPOLA is able to have rising/falling edge value.

### 10.12.6 External Interrupt Enable Register (EIENAB)

When the external interrupt enable register is written to '1', the corresponding external pin interrupt is enabled. The EIEDGE and EIPOLA register defines whether the external interrupt is activated on rising or falling edge or level sensed.

### 10.12.7 Register Map

Table 10-3 Register Map

Name	Address	Dir	Default	Description
IE	A8H	R/W	00H	Interrupt Enable Register
IE1	A9H	R/W	00H	Interrupt Enable Register 1
IE2	AAH	R/W	00H	Interrupt Enable Register 2
IE3	ABH	R/W	00H	Interrupt Enable Register 3
IE4	ACH	R/W	00H	Interrupt Enable Register 4
IE5	ADH	R/W	00H	Interrupt Enable Register 5
IP	B8H	R/W	00H	Interrupt Priority Register
IP1	F8H	R/W	00H	Interrupt Priority Register 1
EIFLAG	A4H	R/W	00H	External Interrupt Flag Register
EIEDGE	A5H	R/W	00H	External Interrupt Edge Register
EIPOLA	A6H	R/W	00H	External Interrupt Polarity Register
EIENAB	A3H	R/W	00H	External Interrupt Enable Register

## 10.13 Interrupt Register Description

The Interrupt Register is used for controlling interrupt functions. Also it has External interrupt control registers. The interrupt register consists of Interrupt Enable Register (IE), Interrupt Enable Register 1 (IE1), Interrupt Enable Register 2 (IE2), Interrupt Enable Register 3 (IE3), Interrupt Enable Register 4 (IE4) and Interrupt Enable Register 5 (IE5). For external interrupt, it consists of External Interrupt Flag Register (EIFLAG), External Interrupt Edge Register (EIEDGE), External Interrupt Polarity Register (EIPOLA) and External Interrupt Enable Register (EIENAB).

### 10.13.1 Register description for Interrupt

#### IE (Interrupt Enable Register) : A8H

7	6	5	4	3	2	1	0
EA	-	INT5E	INT4E	INT3E	INT2E	INT1E	INT0E
R/W	-	R/W	R/W	R/W	R/W	R/W	R/W

Initial value : 00H

<b>EA</b>	Enable or disable all interrupt bits
0	All Interrupt disable
1	All Interrupt enable
<b>INT5E</b>	Enable or disable Pin Change Interrupt 1 (Port 7)
0	Disable
1	Enable
<b>INT4E</b>	Enable or disable Pin Change Interrupt 0 (Port 0)
0	Disable
1	Enable
<b>INT3E</b>	Enable or disable External Interrupt 3
0	Disable
1	Enable
<b>INT2E</b>	Enable or disable External Interrupt 2
0	Disable
1	Enable
<b>INT1E</b>	Enable or disable External Interrupt 1
0	Disable
1	Enable
<b>INT0E</b>	Enable or disable External Interrupt 0
0	Disable
1	Enable

#### IE1 (Interrupt Enable Register 1) : A9H

7	6	5	4	3	2	1	0
-	-	INT11E	INT10E	INT9E	INT8E	INT7E	INT6E
-	-	R/W	R/W	R/W	R/W	R/W	R/W

Initial value : 00H

<b>INT11E</b>	Enable or disable USART1 Tx Interrupt
0	Disable
1	Enable

<b>INT10E</b>	Enable or disable USART1 Rx Interrupt
0	Disable
1	Enable
<b>INT9E</b>	Enable or disable I <sup>2</sup> C Interrupt
0	Disable
1	Enable
<b>INT8E</b>	Enable or disable SPI0 Interrupt
0	Disable
1	Enable
<b>INT7E</b>	Enable or disable USART0 Tx Interrupt
0	Disable
1	Enable
<b>INT6E</b>	Enable or disable USART0 Rx Interrupt
0	Disable
1	Enable

**IE2 (Interrupt Enable Register 2) : AAH**

7	6	5	4	3	2	1	0
-	-	INT17E	INT16E	INT15E	INT14E	INT13E	INT12E
-	-	RW	RW	RW	RW	RW	RW

Initial value : 00H

<b>INT17E</b>	Enable or disable Timer 5 Interrupt
0	Disable
1	Enable
<b>INT16E</b>	Enable or disable Timer 4 Interrupt
0	Disable
1	Enable
<b>INT15E</b>	Enable or disable Timer 3 Interrupt
0	Disable
1	Enable
<b>INT14E</b>	Enable or disable Timer 2 Interrupt
0	Disable
1	Enable
<b>INT13E</b>	Enable or disable Timer 1 Interrupt
0	Disable
1	Enable
<b>INT12E</b>	Enable or disable Timer 0 Interrupt
0	Disable
1	Enable

**IE3 (Interrupt Enable Register 3) : ABH**

7	6	5	4	3	2	1	0
-	-	INT23E	INT22E	INT21E	INT20E	INT19E	INT18E
R	R	RW	RW	RW	RW	RW	RW

Initial value : 00H

<b>INT23E</b>	Enable or disable SPI1 Interrupt
0	Disable

	1	Enable
<b>INT22E</b>	Enable or disable BIT Interrupt	
	0	Disable
	1	Enable
<b>INT21E</b>	Enable or disable WDT Interrupt	
	0	Disable
	1	Enable
<b>INT20E</b>	Enable or disable WT Interrupt	
	0	Disable
	1	Enable
<b>INT19E</b>	Enable or disable EEPROM Interrupt	
	0	Disable
	1	Enable
<b>INT18E</b>	Enable or disable ADC Interrupt	
	0	Disable
	1	Enable

**IE4 (Interrupt Enable Register 4) : ACH**

7	6	5	4	3	2	1	0
-	-	INT29E	INT28E	INT27E	INT26E	INT25E	INT24E
R	R	RW	RW	RW	RW	RW	RW

Initial value : 00H

<b>INT29E</b>	Enable or disable External Interrupt 5	
	0	Disable
	1	Enable
<b>INT28E</b>	Enable or disable External Interrupt 4	
	0	Disable
	1	Enable
<b>INT27E</b>	Enable or disable USART3 Tx Interrupt	
	0	Disable
	1	Enable
<b>INT26E</b>	Enable or disable USART3 Rx Interrupt	
	0	Disable
	1	Enable
<b>INT25E</b>	Enable or disable USART2 Tx Interrupt	
	0	Disable
	1	Enable
<b>INT24E</b>	Enable or disable USART2 Rx Interrupt	
	0	Disable
	1	Enable

**IE5 (Interrupt Enable Register 5) : ADH**

7	6	5	4	3	2	1	0
-	-	INT35E	INT34E	INT33E	INT32E	INT31E	INT30E
R	R	RW	RW	RW	RW	RW	RW

Initial value : 00H

<b>INT35E</b>	Reserved
---------------	----------



	0	Disable
	1	Enable
<b>INT34E</b>	Reserved	
	0	Disable
	1	Enable
<b>INT33E</b>	Reserved	
	0	Disable
	1	Enable
<b>INT32E</b>	Reserved	
	0	Disable
	1	Enable
<b>INT31E</b>	Enable or disable External Interrupt 7	
	0	Disable
	1	Enable
<b>INT30E</b>	Enable or disable External Interrupt 6	
	0	Disable
	1	enable

**IP (Interrupt Priority Register) : B8H**

<b>7</b>	<b>6</b>	<b>5</b>	<b>4</b>	<b>3</b>	<b>2</b>	<b>1</b>	<b>0</b>
IP7	IP6	IP5	IP4	IP3	IP2	IP1	IP0
RW	RW	RW	RW	RW	RW	RW	RW

Initial value : 00H

**IP1 (Interrupt Priority Register 1) : F8H**

<b>7</b>	<b>6</b>	<b>5</b>	<b>4</b>	<b>3</b>	<b>2</b>	<b>1</b>	<b>0</b>
IP17	IP16	IP15	IP14	IP13	IP12	IP11	IP10
RW	RW	RW	RW	RW	RW	RW	RW

Initial value : 00H

<b>IP[7:0], IP1[7:0]</b>	Select Interrupt Group Priority		
	IP1x	IPx	Description
	0	0	level 0 (lowest)
	0	1	level 1
	1	0	level 2
	1	1	level 3 (highest)

**EIFLAG (External Interrupt Flag Register) : A4H**

<b>7</b>	<b>6</b>	<b>5</b>	<b>4</b>	<b>3</b>	<b>2</b>	<b>1</b>	<b>0</b>
FLAG7	FLAG6	FLAG5	FLAG4	FLAG3	FLAG2	FLAG1	FLAG0
RW	RW	RW	RW	RW	RW	RW	RW

Initial value : 00H

<b>FLAG[7:0]</b>	If External Interrupt is occurred, the flag becomes '1'. The flag can be cleared by writing a '0' to bit	
	0	External Interrupt not occurred
	1	External Interrupt occurred

**EIEDGE (External Interrupt Edge Register) : A5H**

7	6	5	4	3	2	1	0
EDGE7	EDGE6	EDGE5	EDGE4	EDGE3	EDGE2	EDGE1	EDGE0
RW	RW	RW	RW	RW	RW	RW	RW

Initial value : 00H

**EDGE[7:0]** Determines which type of edge or level sensitive interrupt may occur.

- 0 Level (default)
- 1 Edge

**EIPOLA (External Interrupt Polarity Register) : A6H**

7	6	5	4	3	2	1	0
POLA7	POLA6	POLA5	POLA4	POLA3	POLA2	POLA1	POLA0
RW	RW	RW	RW	RW	RW	RW	RW

Initial value : 00H

**POLA[7:0]** According to EIEDGE, External interrupt polarity register has a different means. If EIEDGE is level type, external interrupt polarity is able to have Low/High level value. If EIEDGE is edge type, external interrupt polarity is able to have rising/ falling edge value.

Level case:

- 0 When High level, Interrupt occurred (default)
- 1 When Low level, Interrupt occurred

Edge case:

- 0 When Rising edge, Interrupt occurred (default)
- 1 When Falling edge, Interrupt occurred

**EIENAB (External Interrupt Enable Register) : A3H**

7	6	5	4	3	2	1	0
ENAB7	ENAB6	ENAB5	ENAB4	ENAB3	ENAB2	ENAB1	ENAB0
RW	RW	RW	RW	RW	RW	RW	RW

Initial value : 00H

**ENAB[7:0]** Control External Interrupt

- 0 Disable (default)
- 1 Enable

## 11. Peripheral Hardware

### 11.1 Clock Generator

#### 11.1.1 Overview

As shown in Figure 11.1, the clock generator produces the basic clock pulses which provide the system clock to be supplied to the CPU and the peripheral hardware. It contains main-frequency clock oscillator. The system clock operation can be easily obtained by attaching a crystal between the XIN and XOUT pin, respectively. The system clock can also be obtained from the external oscillator. In this case, it is necessary to put the external clock signal into the XIN pin and open the XOUT pin. The default system clock is INT-RC Oscillator and the default division rate is one. In order to stabilize system internally, use 1MHz RING oscillator for BIT, WDT and ports de-bounce.

- Calibrated Internal RC Oscillator (8 MHz)
  - . INT-RC OSC/1 (Default system clock)
  - . INT-RC OSC/2 (4 MHz)
  - . INT-RC OSC/4 (2 MHz)
  - . INT-RC OSC/8 (1 MHz)
- Crystal Oscillator (1~10 MHz)
- Sub-Clock Crystal Oscillator (32.768 KHz)
- PLL output (1.38~20.185 MHz)

#### 11.1.2 Block Diagram

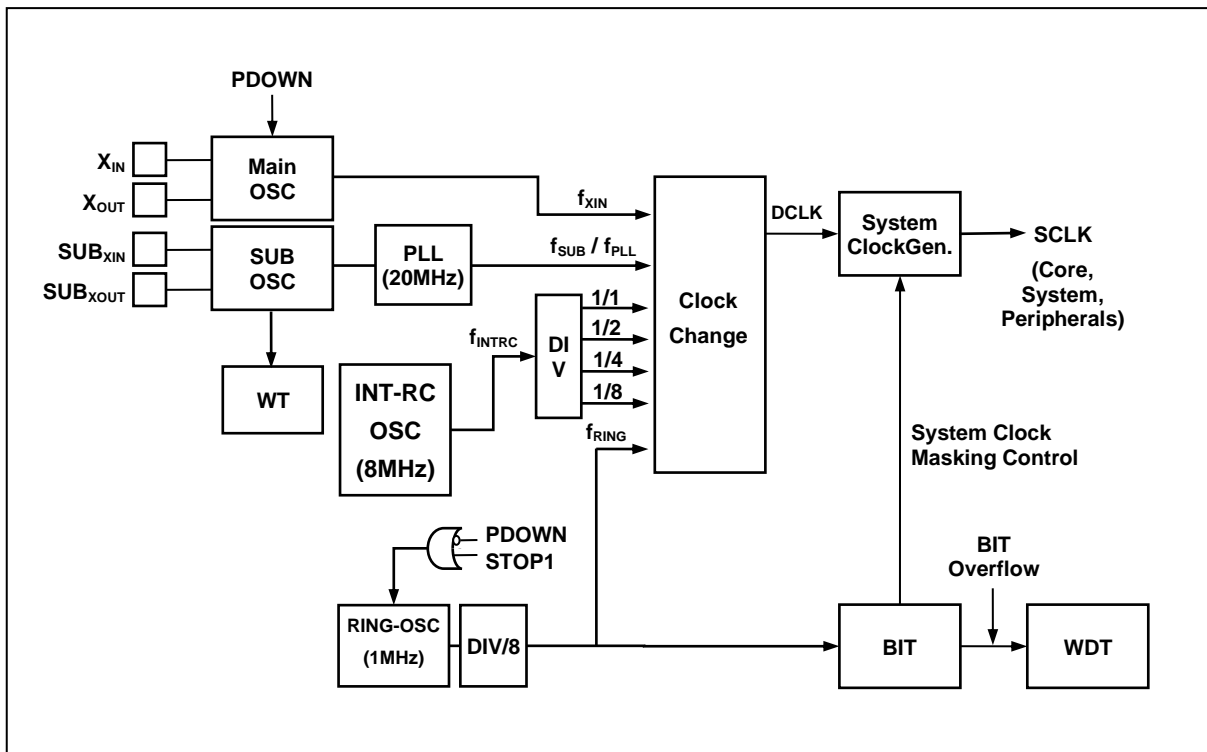

Figure 11.1 Clock Generator Block Diagram

### 11.1.3 Register Map

Table 11-1 Register Map

Name	Address	Dir	Default	Description
SCCR	8AH	R/W	04H	System and Clock Control Register
PLLCR	A7H	R/W	00H	PLL Control Register

### 11.1.4 Clock Generator Register description

The Clock Generation Register uses clock control for system operation. The clock generation consists of System and Clock register.

### 11.1.5 Register description for Clock Generator

#### SCCR (System and Clock Control Register) : 8AH

7	6	5	4	3	2	1	0
STOP1	DIV1	DIV0	CBYS	ISTOP	XSTOP	CS1	CS0
R/W	R/W	R/W	R/W	R/W	R/W	R/W	R/W

Initial value : 04H

<b>STOP1</b>	Control the STOP Mode. Note) when PCON=0x03, It is applied. But when PCON=0x01, don't set this bit. 0 STOP2 Mode (at PCON=0x03) (default) 1 STOP1 Mode (at PCON=0x03)
<b>DIV[1:0]</b>	When using fINTRC as system clock, determine division rate. Note) when using fINTRC as system clock, only division rate come into effect. Note) To change by software, CBYS set to '1' DIV1 DIV0 description 0 0 fINTRC/1 (8MHz, default) 0 1 fINTRC/2 (4MHz) 1 0 fINTRC/4 (2MHz) 1 1 fINTRC/8 (1MHz)
<b>CBYS</b>	Control the scheme of clock change. If this bit set to '0', clock change is controlled by hardware. But if this set to '1', clock change is controlled by software. Ex) when setting CS[1:0], if CBYS bit set to '0', it is not changed right now, CPU goes to STOP mode and then when wake-up, it applies to clock change. Note) when clear this bit, keep other bits in SCCR. 0 Clock changed by hardware during stop mode (default) 1 Clock changed by software
<b>ISTOP</b>	Control the operation of INT-RC Oscillation Note) when CBYS='1', It is applied 0 RC-Oscillation enable (default) 1 RC-Oscillation disable
<b>XSTOP</b>	Control the operation of X-Tal Oscillation Note1) when CBYS='1', It is applied

Note2) if XINENA bit in FUSE\_CONF to '0', XSTOP is fixed to '1'

	0	X-Tal Oscillation enable	
	1	X-Tal Oscillation disable (default)	
<b>CS[1:0]</b>	Determine System Clock Note) by CBYS bit, reflection point is decided		
	CS1	CS0	
	0	0	fINTRC INTRC (8 MHz)
	0	1	fXIN Main Clock (1~10 MHz)
	1	0	fSUB / fPLL (32.768 KHz, 1.38~20.185MHz)
	1	1	fRING (125 KHz)

**PLLCR (Phase Locked Loop Control Register) : A7H**

7	6	5	4	3	2	1	0
PLLSTAT	PLLCKS	VDConSUB	PLLFB		PLLPD		PLLEN
R	R/W	R/W	R/W	R/W	R/W	R/W	R/W

Initial value : 00H

<b>PLLSTAT</b>	PLL Status flag (read only bit)		
	0	PLL output is Fvcoin (32.768KHz bypass)	
	1	PLL output is Fpll	
<b>PLLCKS</b>	PLL output clock selection control PLLEN should be set "1" to use bypass control. PLL VCO would not stop in the case of PLLCKS is "0" (32KHz). In addition, this bit automatically set by interrupt event on sub-active or power down.		
	0	PLL output is Fvcoin (32.768KHz bypass, default)	
	1	PLL output is Fpll	
<b>VDConSUB</b>	Normal Power Selection for PLLCKS control Limited VDC power when PLLCKS is "0" (32.768KHz) - Limited VDC consumes about 0.1mA to drive 1mA (default) - In this mode, user must care about power consumption		
	0		
	1	Normal VDC power when PLLCKS is "0" (32.768KHz) - Normal VDC consumes about 1mA to drive about 10mA	
<b>PLLFB[1:0]</b>	PLL Feedback Divider control		
	PLLFB1	PLLFB0	
	0	0	FBdiv = 616 (default)
	0	1	FBdiv = 512
	1	0	FBdiv = 450
	1	1	FBdiv = 338
<b>PLLPD[1:0]</b>	PLL Post Divider Control		
	PLLPD1	PLLPD0	
	0	0	M = 1 (default)
	0	1	M = 2
	1	0	M = 4
	1	1	M = 8
<b>PLLEN</b>	PLL Enable control		
	0	PLL disable (2 SUB-OSC clock need for disable, default)	
	1	PLL enable	

$$F_{vco} = F_{vcoin} * FB_{div}$$

$$F_{pll} = F_{vco} / M$$

$$F_{vco} = (32.768 \text{ KHz} * 616) = 20.185088 \text{ MHz (default)}$$

$$F_{vco} = (32.768 \text{ KHz} * 512) = 16.777216 \text{ MHz}$$

$$F_{vco} = (32.768 \text{ KHz} * 450) = 14.745600 \text{ MHz}$$

$$F_{vco} = (32.768 \text{ KHz} * 338) = 11.075584 \text{ MHz}$$

### 11.1.6 Power control for 32.768KHz Clock operation

MC95FG0128A has two different way to use 32.768KHz operation.

First, user can select 32.768KHz clock on PLL disable as a low power operation(Sub-active mode, CS[1:0] = 0x2 of SCCR, PLLCKS = "0" and PLEN = "0" of PLLCR). In this mode, user also has to care about power consumption of whole chip. Because, to achieve lower power consumption in sub-active mode, MC95FG0128A has a smaller SUB-ACTIVE VDC(voltage Down Converter) which is automatically enable in sub-active mode and has only 1mA current capability while main VDC(for normal operation) is off.

Second, if user wanted to use 32.768KHz on PLL enable(CS[1:0] = 0x2 of SCCR, PLLCKS = "0" and PLEN = "1" of PLLCR), in this case PLL VCO block would not stop so need more power than the first case. In this case, user can select VDC mode with VDConSUB bit of PLLCR. If VDConSUB = "0", then main 10mA VDC is off and only SUB\_ACTIVE VDC of 1mA is available. If user set VDConSUB = "1", main VDC, which has 10mA of current drive capability for 1.8V output, will work for 32.768KHz and main VDC itself will consume about 1mA current to operate while SUB\_ACTIVE VDC consume 0.1mA.

**Table 11-2 VDC current consumption**

PLEN@PLLCR (PLLCKS = 0)	VDConSUB@PLLCR (PLLCKS = 0)	MAIN VDC	SUB VDC	VDC current capability	VDC current consumption
1	1	ON	OFF	20mA@1.8V	1mA
	0	OFF	ON	1mA@1.8V	0.1mA
0	X (don't care)	OFF	ON	1mA@1.8V	0.1mA

## 11.2 BIT

### 11.2.1 Overview

The MC95FG0128A has one 8-bit Basic Interval Timer that is free-run and can't stop. Block diagram is shown in Figure 11.2. In addition, the Basic Interval Timer generates the time base for watchdog timer counting. It also provides a Basic interval timer interrupt (BITF).

The MC95FG0128A has these Basic Interval Timer (BIT) features:

- During Power On, BIT gives a stable clock generation time
- On exiting Stop mode, BIT gives a stable clock generation time
- As clock function, time interrupt occurrence

### 11.2.2 Block Diagram

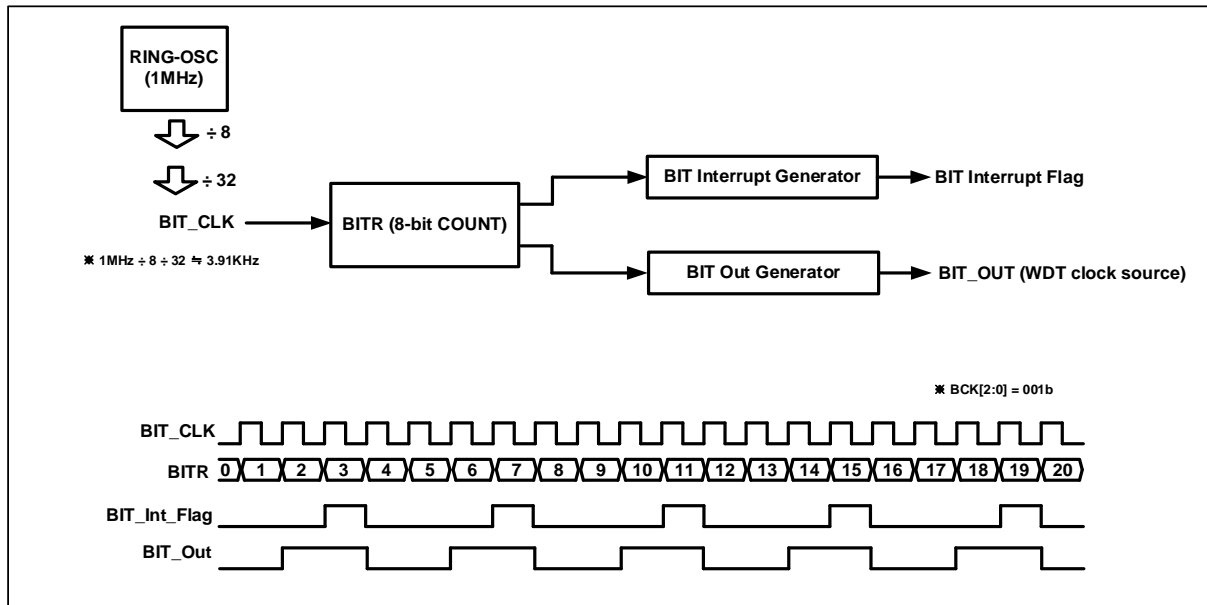

Figure 11.2 BIT Block Diagram

### 11.2.3 Register Map

Table 11-3 Register Map

Name	Address	Dir	Default	Description
BCCR	8BH	R/W	05H	BIT Clock Control Register
BITR	8CH	R	00H	Basic Interval Timer Register

### 11.2.4 Bit Interval Timer Register description

The Bit Interval Timer Register consists of BIT Clock control register (BCCR) and Basic Interval Timer register (BITR). If BCLR bit set to '1', BITR becomes '0' and then counts up. After 1 machine cycle, BCLR bit is cleared as '0' automatically.

### 11.2.5 Register description for Bit Interval Timer

#### BCCR (BIT Clock Control Register) : 8BH

7	6	5	4	3	2	1	0
BITF	-	-	-	BCLR	BCK2	BCK1	BCK0
RW	R	R	R	RW	RW	RW	RW

Initial value : 05H

**BITF** When BIT Interrupt occurs, this bit becomes '1'. For clearing bit, write '0' to this bit.

0 no generation

1 generation

**BCLR** If BCLR Bit is written to '1', BIT Counter is cleared as '0'

0 Free Running

1 Clear Counter

**BCK[2:0]** Select BIT overflow period (BIT Clock  $\approx$  3.9 KHz)

BCK2 BCK1 BCK0

0 0 0 0.512msec (BIT Clock \* 2)

0 0 1 1.024msec

0 1 0 2.048msec

0 1 1 4.096msec

1 0 0 8.192msec

1 0 1 16.384msec (default)

1 1 0 32.768msec

1 1 1 65.536msec

#### BITR (Basic Interval Timer Register) : 8CH

7	6	5	4	3	2	1	0
BIT7	BIT6	BIT5	BIT4	BIT3	BIT2	BIT1	BIT0
R	R	R	R	R	R	R	R

Initial value : 00H

**BIT[7:0]** BIT Counter



### 11.3 WDT

#### 11.3.1 Overview

The watchdog timer rapidly detects the CPU malfunction such as endless looping caused by noise or the like, and resumes the CPU to the normal state. The watchdog timer signal for detecting malfunction can be selected either a reset CPU or an interrupt request. When the watchdog timer is not being used for malfunction detection, it can be used as a timer to generate an interrupt at fixed intervals. It is possible to use free running 8-bit timer mode (WDTRSON='0') or watch dog timer mode (WDTRSON='1') as setting WDTMR[6] bit. If writing WDTMR[5] to '1', WDT counter value is cleared and counts up. After 1 machine cycle, this bit has '0' automatically. The watchdog timer consists of 8-bit binary counter and the watchdog timer data register. When the value of 8-bit binary counter is equal to the 8 bits of WDTR, the interrupt request flag is generated. This can be used as Watchdog timer interrupt or reset the CPU in accordance with the bit WDTRSON.

The clock source of Watch Dog Timer is BIT overflow output. The interval of watchdog timer interrupt is decided by BIT overflow period and WDTR set value. The equation is as below

$$\text{WDT Interrupt Interval} = (\text{BIT Interrupt Interval}) \times (\text{WDTR Value} + 1)$$

#### 11.3.2 Block Diagram

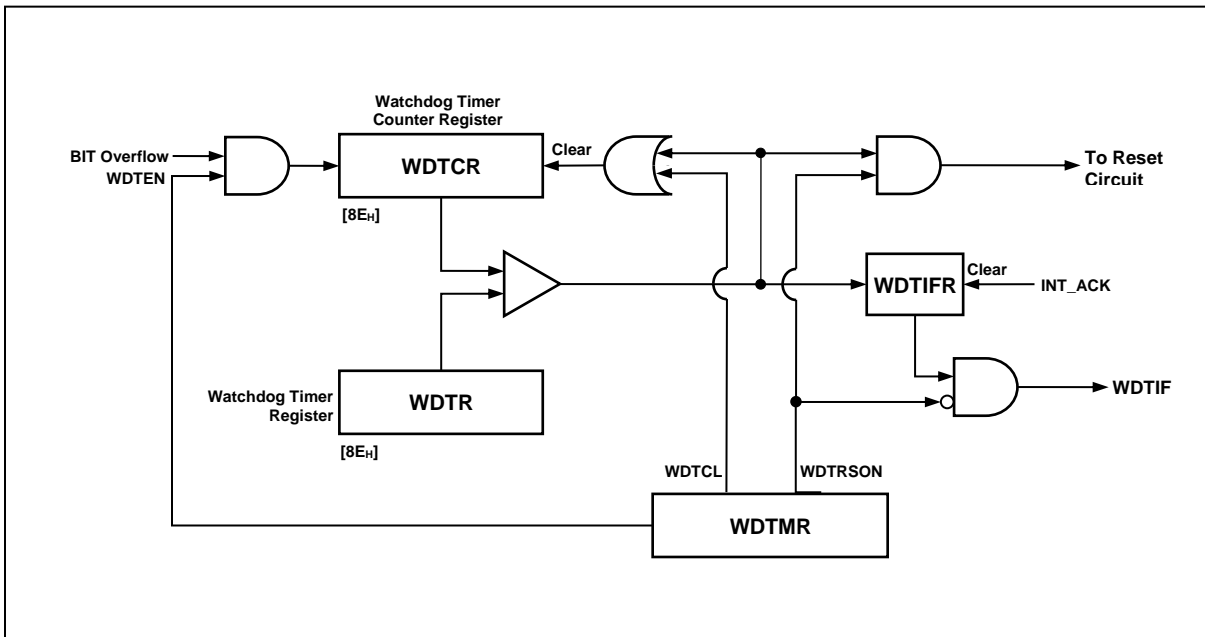

Figure 11.3 WDT Block Diagram

#### 11.3.3 Register Map

Table 11-4 Register Map

Name	Address	Dir	Default	Description
WDTR	8EH	W	FFH	Watch Dog Timer Register
WDTCR	8EH	R	00H	Watch Dog Timer Counter Register
WDTMR	8DH	R/W	00H	Watch Dog Timer Mode Register

### 11.3.4 Watch Dog Timer Register description

The Watch dog timer (WDT) Register consists of Watch Dog Timer Register (WDTR), Watch Dog Timer Counter Register (WDTCR) and Watch Dog Timer Mode Register (WDTMR).

### 11.3.5 Register description for Watch Dog Timer

#### WDTR (Watch Dog Timer Register: Write Case) : 8EH

7	6	5	4	3	2	1	0
WDTR7	WDTR6	WDTR5	WDTR4	WDTR3	WDTR2	WDTR1	WDTR0
W	W	W	W	W	W	W	W

Initial value : FFH

**WDTR[7:0]** Set a period  
 $WDT\ Interrupt\ Interval = (BIT\ Interrupt\ Interval) \times (WDTR\ Value + 1)$

Note) To guarantee proper operation, the data should be greater than 01H.

#### WDTCR (Watch Dog Timer Counter Register: Read Case) : 8EH

7	6	5	4	3	2	1	0
WDTCR7	WDTCR6	WDTCR5	WDTCR4	WDTCR3	WDTCR2	WDTCR1	WDTCR0
R	R	R	R	R	R	R	R

Initial value : 00H

**WDTCR[7:0]** WDT Counter

#### WDTMR (Watch Dog Timer Mode Register) : 8DH

7	6	5	4	3	2	1	0
WDTEN	WDTMRSON	WDTCL	-	-	-	-	WDTIFR
RW	RW	RW	-	-	-	-	RW

Initial value : 00H

**WDTEN** Control WDT operation  
 0 disable  
 1 enable

**WDTMRSON** Control WDT Reset operation  
 0 Free Running 8-bit timer  
 1 Watch Dog Timer Reset ON

**WDTCL** Clear WDT Counter  
 0 Free Run  
 1 Clear WDT Counter (auto clear after 1 Cycle)

**WDTIFR** When WDT Interrupt occurs, this bit becomes '1'. For clearing bit, write '0' to this bit or auto clear by INT\_ACK signal.  
 0 WDT Interrupt no generation  
 1 WDT Interrupt generation

### 11.3.6 WDT Interrupt Timing Waveform

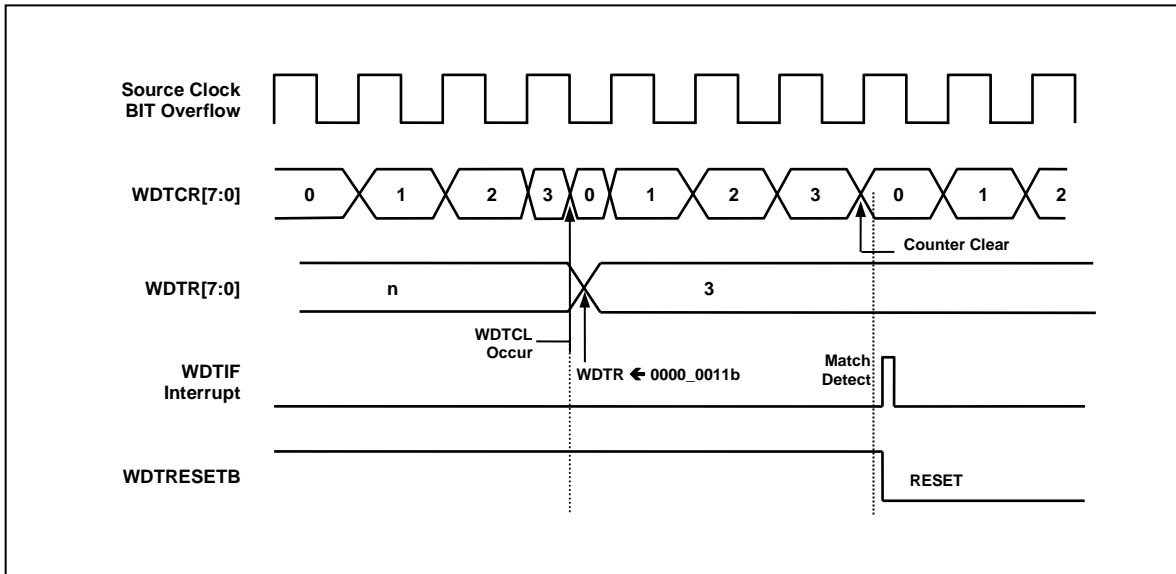

Figure 11.4 WDT Interrupt Timing Waveform

## 11.4 WT

### 11.4.1 Overview

The watch timer has the function for RTC (Real Time Clock) operation. It is generally used for RTC design. The internal structure of the watch timer consists of the clock source select circuit, timer counter circuit, output select circuit and watch timer mode register. To operate the watch timer, determine the input clock source, output interval and set WTEN to '1' in watch timer mode register (WTMR). It is able to execute simultaneously or individually. To stop or reset WT, clear the WTEN bit in WTMR register. Even if CPU is STOP mode, sub clock is able to be alive so WT can continue the operation. The watch timer counter circuits may be composed of 21-bit counter which is low 14-bit with binary counter and high 7-bit with auto reload counter in order to raise resolution. In WTR, it can control WT clear and set Interval value at write time, and it can read 7-bit WT counter value at read time.

### 11.4.2 Block Diagram

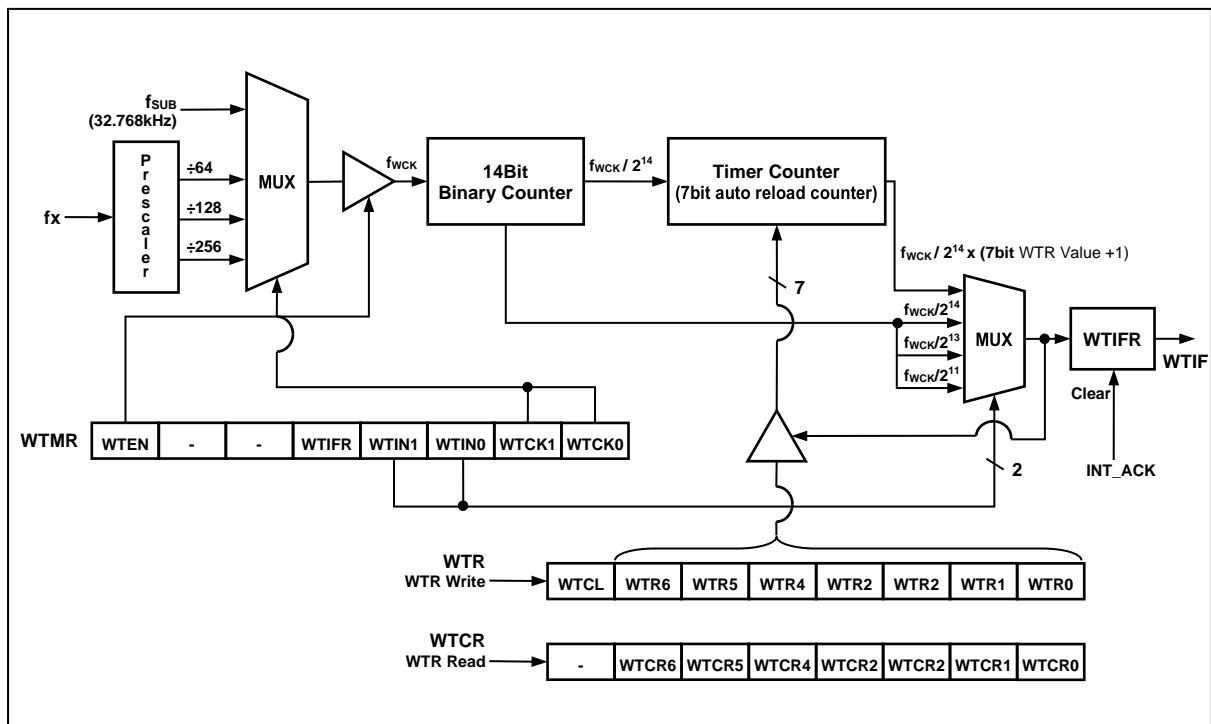

Figure 11.5 Watch Timer Block Diagram

### 11.4.3 Register Map

Table 11-5 Register Map

Name	Address	Dir	Default	Description
WTMR	9DH	R/W	00H	Watch Timer Mode Register
WTR	9EH	W	7FH	Watch Timer Register
WTCR	9EH	R	00H	Watch Timer Counter Register

**11.4.4 Watch Timer Register description**

The watch timer register (WT) consists of Watch Timer Mode Register (WTMR), Watch Timer Counter Register (WTCR) and Watch Timer Register (WTR). As WTMR is 6-bit writable/readable register, WTMR can control the clock source (WTCK), interrupt interval (WTIN) and function enable/disable (WTEN). Also there is WT interrupt flag bit (WTIFR).

**11.4.5 Register description for Watch Timer**

**WTMR (Watch Timer Mode Register) : 9DH**

7	6	5	4	3	2	1	0
WTEN	-	-	WTIFR	WTIN1	WTIN0	WTCK1	WTCK0
RW	-	-	RW	RW	RW	RW	RW

Initial value : 00H

- WTEN** Control Watch Timer  
0 disable  
1 enable
- WTIFR** When WT Interrupt occurs, this bit becomes '1'. For clearing bit, write '0' to this bit or auto clear by INT\_ACK signal.  
0 WT Interrupt no generation  
1 WT Interrupt generation
- WTIN[1:0]** Determine interrupt interval  

WTIN1	WTIN0	description
0	0	fwck/2048
0	1	fwck/8192
1	0	fwck/16384
1	1	fwck/16384 x (7bit WT Value)
- WTCK[1:0]** Determine Source Clock  

WTCK1	WTCK0	description
0	0	fsub
0	1	fx/256
1	0	fx/128
1	1	fx/64

Remark: fx- Main system clock oscillation frequency  
 fsub- Sub clock oscillation frequency  
 fwck- selected Watch Timer clock

**WTR (Watch Timer Register: Write Case) : 9EH**

7	6	5	4	3	2	1	0
---	---	---	---	---	---	---	---

WTCL	WTR6	WTR5	WTR4	WTR3	WTR2	WTR1	WTR0
W	W	W	W	W	W	W	W

Initial value : 7FH

**WTCL** Clear WT Counter

0 Free Run

1 Clear WT Counter (auto clear after 1 Cycle)

**WTR[6:0]** Set WT period

WT Interrupt Interval=(fwck/2<sup>14</sup>) x(7bit WT Value+1)

Note) To guarantee proper operation, it is greater than 01H to write WTR.

### WTCR (Watch Timer Counter Register: Read Case) : 9EH

7	6	5	4	3	2	1	0
	WTCR6	WTCR5	WTCR4	WTCR3	WTCR2	WTCR1	WTCR0
-	R	R	R	R	R	R	R

Initial value : 00H

**WTCR[6:0]** WT Counter

## 11.5 Timer/PWM

### 11.5.1 8-bit Timer/Event Counter 0, 1

#### 11.5.1.1 Overview

Timer 0 and timer 1 can be used either two 8-bit timer/counter or one 16-bit timer/counter with combine them. Each 8-bit timer/event counter module has multiplexer, 8-bit timer data register, 8-bit counter register, mode register, input capture register, comparator. For PWM, it has PWM register (T1PPR, T1PDR, T1PWHR).

It has seven operating modes:

- 8 Bit Timer/Counter Mode
- 8 Bit Capture Mode
- 8 Bit Compare Output Mode
- 16 Bit Timer/Counter Mode
- 16 Bit Capture Mode
- 16 Bit Compare Output Mode
- PWM Mode

Note> TxDR must be set to higher than 0x03 for guaranteeing operation.

The timer/counter can be clocked by an internal or external clock source (external EC0). The clock source is selected by clock select logic which is controlled by the clock select (T0CK[2:0], T1CK[1:0]).

- TIMER0 clock source : fX/2, 4, 16, 64, 256, 1024, 4096, EC0
- TIMER1 clock source : fX/1, 2, 16, T0CK

In the capture mode, by INT0, INT1, the data is captured into Input Capture Register. The TIMER 0 outputs the compare result to T0 port in 8/16-bit mode. Also the timer 1 outputs the result T1 port in the timer mode and the PWM wave form to PWM3 in the PWM mode.

**Table 11-6 Operating Modes of Timer**

16 Bit	CAP0	CAP1	PWM1E	T0CK[2:0]	T1CK[1:0]	T0/1_PE	TIMER 0	Timer 1
0	0	0	0	XXX	XX	00	8 Bit Timer	8 Bit Timer
0	0	1	0	111	XX	00	8 Bit Event Counter	8 Bit Capture
0	1	0	0	XXX	XX	01	8 Bit Capture	8 Bit Compare Output
0	0	0	1	XXX	XX	11	8 Bit Timer/Counter	10 Bit PWM
1	0	0	0	XXX	11	00	16 Bit Timer	
1	0	0	0	111	11	00	16 Bit Event Counter	
1	1	1	0	XXX	11	00	16 Bit Capture	
1	0	0	0	XXX	11	01	16 Bit Compare Output	

11.5.1.2 8 Bit Timer/Counter Mode

The 8-bit Timer/Counter Mode is selected by control registers as shown in Figure 11.6.

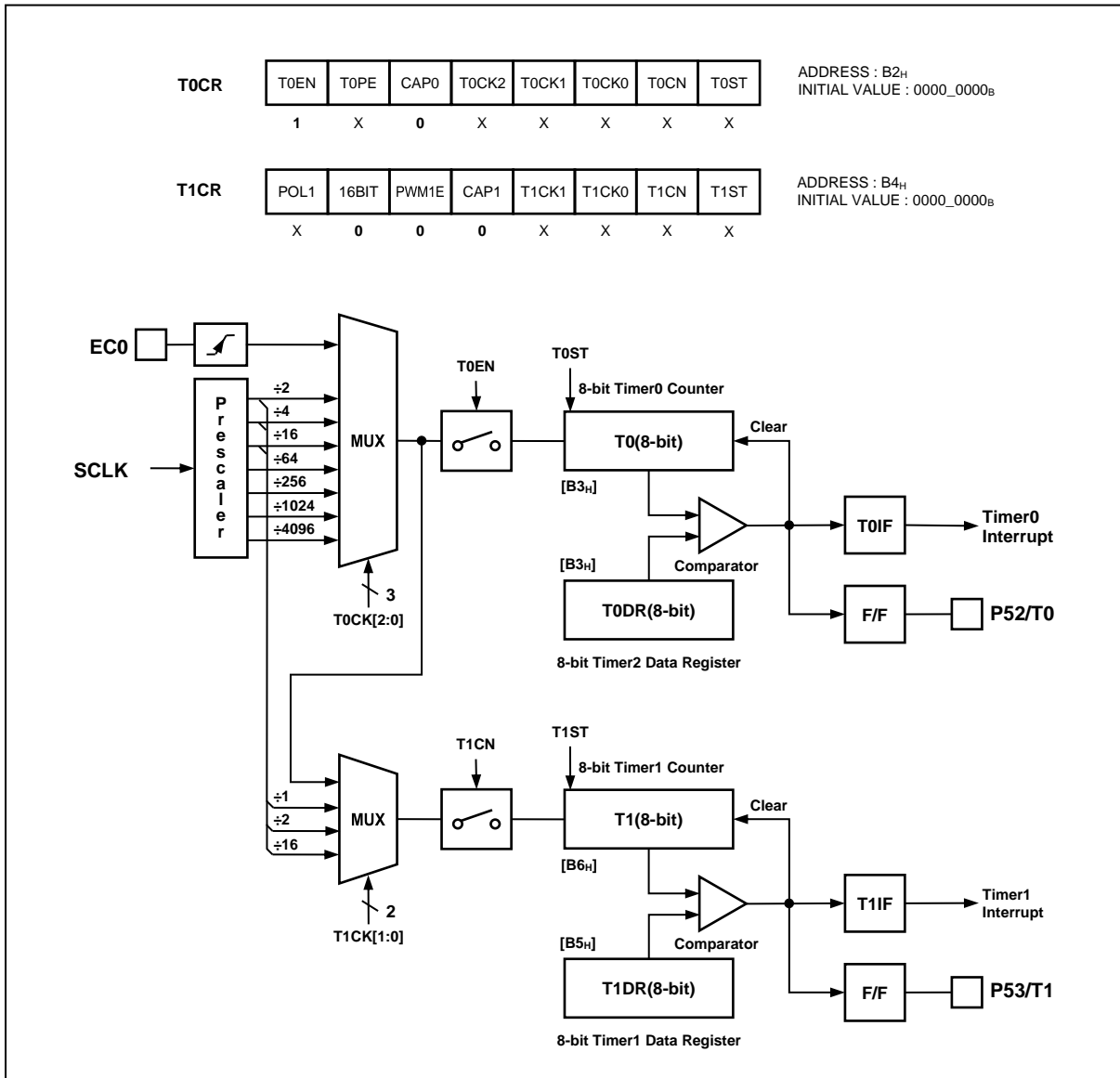

Figure 11.6 8 Bit Timer/Event Counter2, 3 Block Diagram

The two 8-bit timers have each counter and data register. The counter register is increased by internal or external clock input. The timer 0 can use the input clock with 2, 4, 8, 32, 128, 512, 2048 prescaler division rates (T0CK[2:0]). The timer 1 can use the input clock with 1, 2, 8 and timer 0 overflow clock (T1CK[1:0]). When the value of T0, 1 value and the value of T0DR, T1DR are respectively identical in Timer 0, 1, the interrupt of timer P2, 3 occurs. The external clock (EC0) counts up the timer at the rising edge. If EC0 is selected from T0CK[2:0], EC0 port becomes input port. The timer 1 can't use the external EC0 clock.



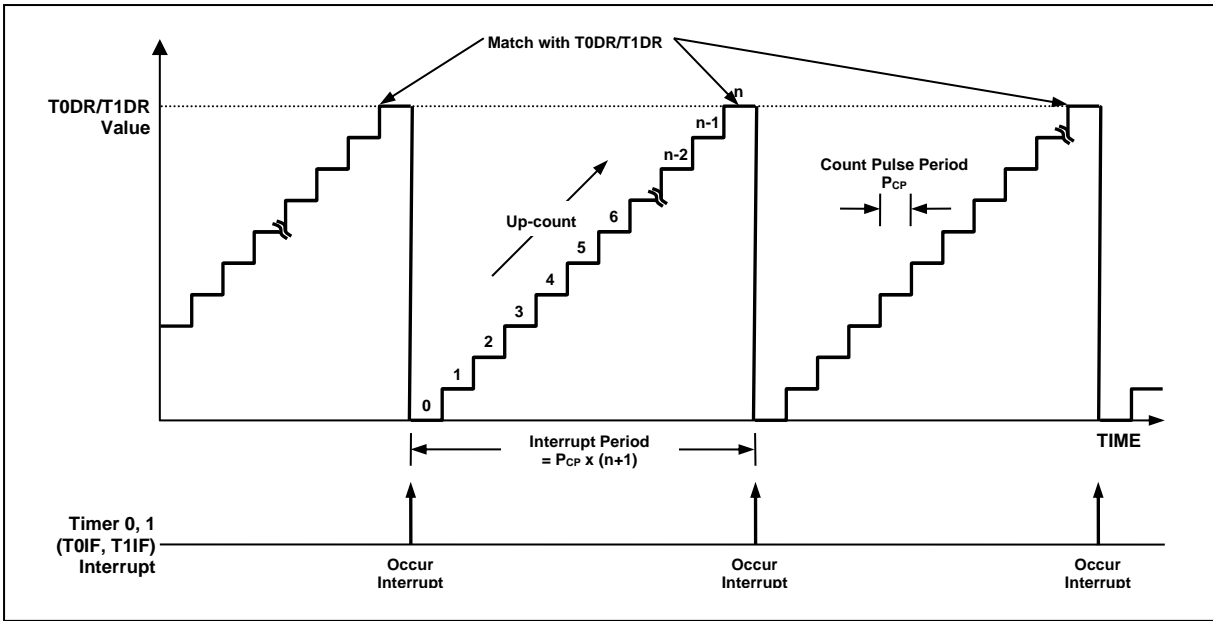

Figure 11.7 Timer/Event Counter0, 1 Example

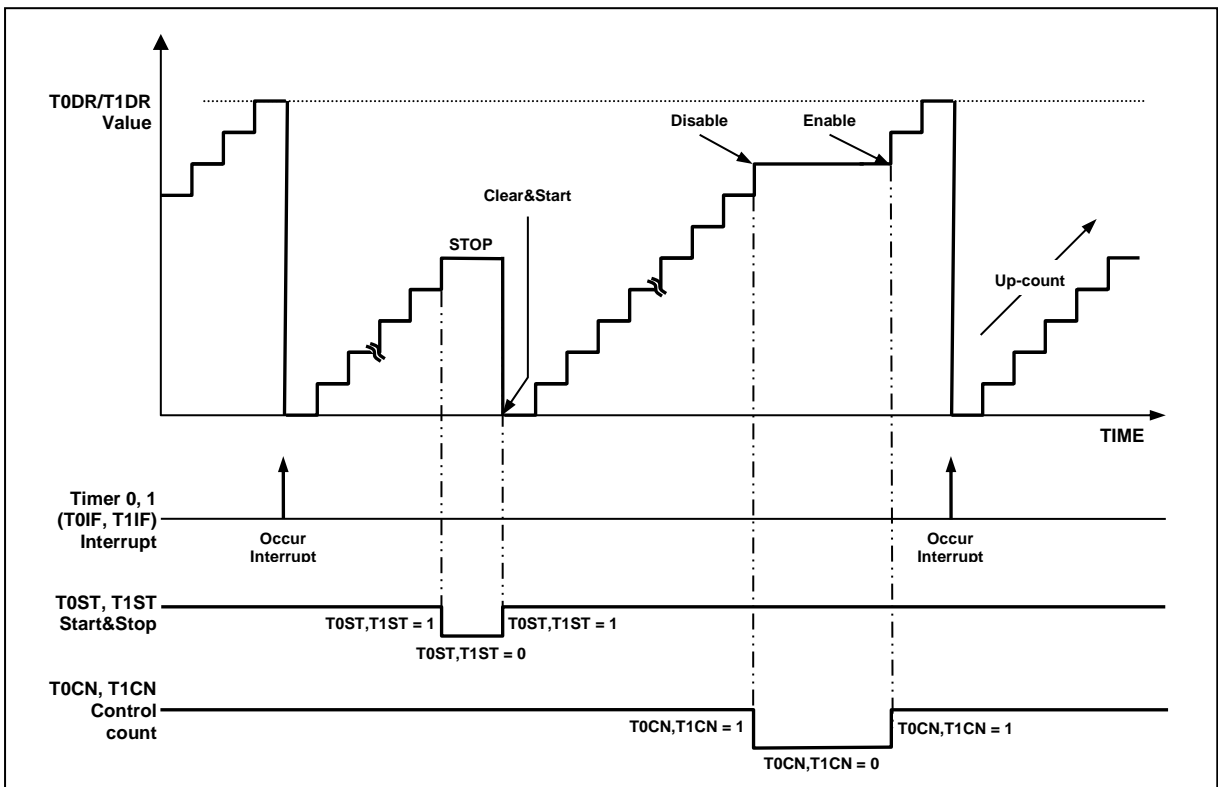

Figure 11.8 Operation Example of Timer/Event Counter0, 1

### 11.5.1.3 16 Bit Timer/Counter Mode

The timer register is being run with all 16bits. A 16-bit timer/counter register T0, T1 are incremented from 0003H to FFFFH until it matches T0DR, T1DR and then resets to 0000H. the match output generates the Timer 0 interrupt ( no timer 1 interrupt). The clock source is selected from T0CK[2:0] and T1CK[1:0] must set 11b and 16BIT bit must set to '1'. The timer 0 is LSB 8-bit, the timer 1 is MSB 8-bit. T0DR must not be 0x00(0x01~0xFF). The 16-bit mode setting is shown as Figure 11.9.

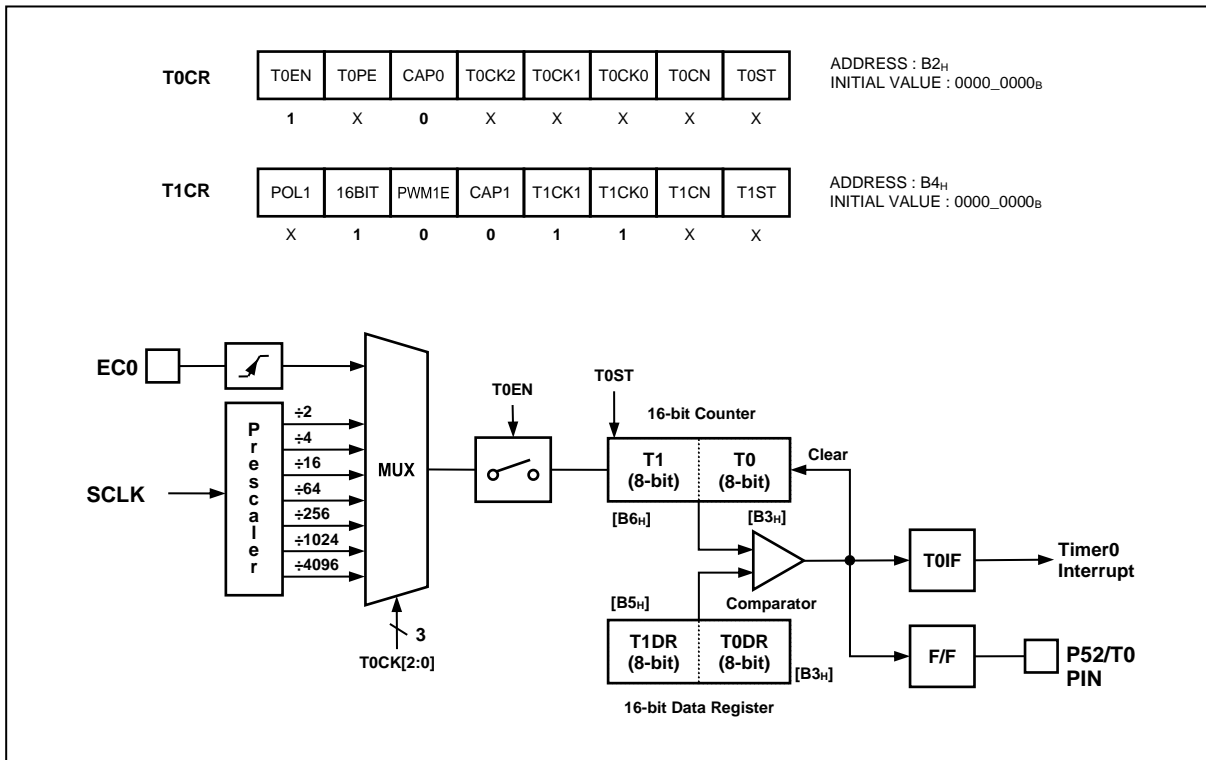

Figure 11.9 16 Bit Timer/Event Counter0, 1 Block Diagram

### 11.5.1.4 8-Bit Capture Mode

The timer 0, 1 capture mode is set by CAP0, CAP1 as '1'. The clock source can use the internal/external clock. Basically, it has the same function of the 8-bit timer/counter mode and the interrupt occurs at T0, 1 and T0DR, T1DR matching time, respectively. The capture result is loaded into CDR0, CDR1. The T0, T1 value is automatically cleared by hardware and restarts counter.

This timer interrupt in capture mode is very useful when the pulse width of captured signal is wider than the maximum period of timer.

As the EIEDGE and EIPOLA register setting, the external interrupt INT0, INT1 function is chosen.

The CDR0, T0 and T0DR are in same address. In the capture mode, reading operation is read the CDR0, not T0DR because path is opened to the CDR0. The CDR1 has the same function.

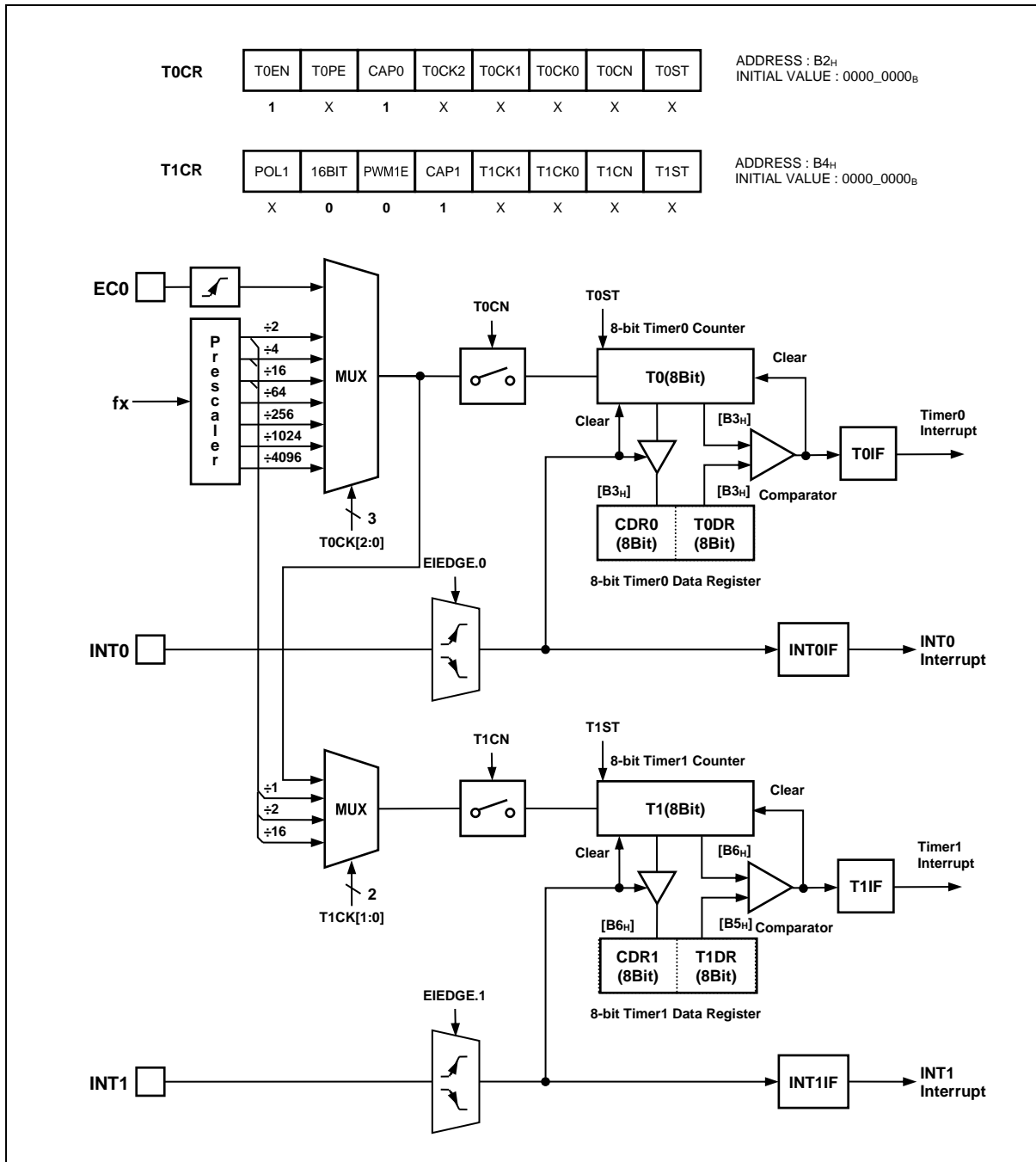

Figure 11.10 8-bit Capture Mode for Timer0, 1

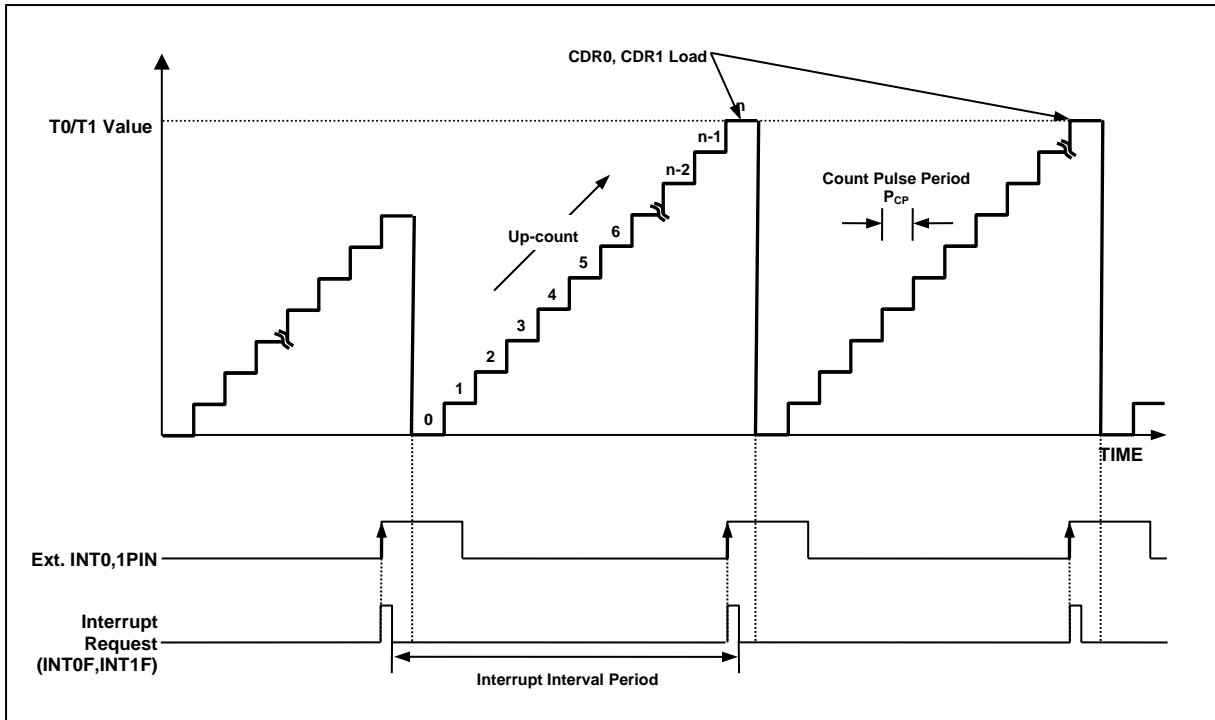

Figure 11.11 Input Capture Mode Operation of Timer 0, 1

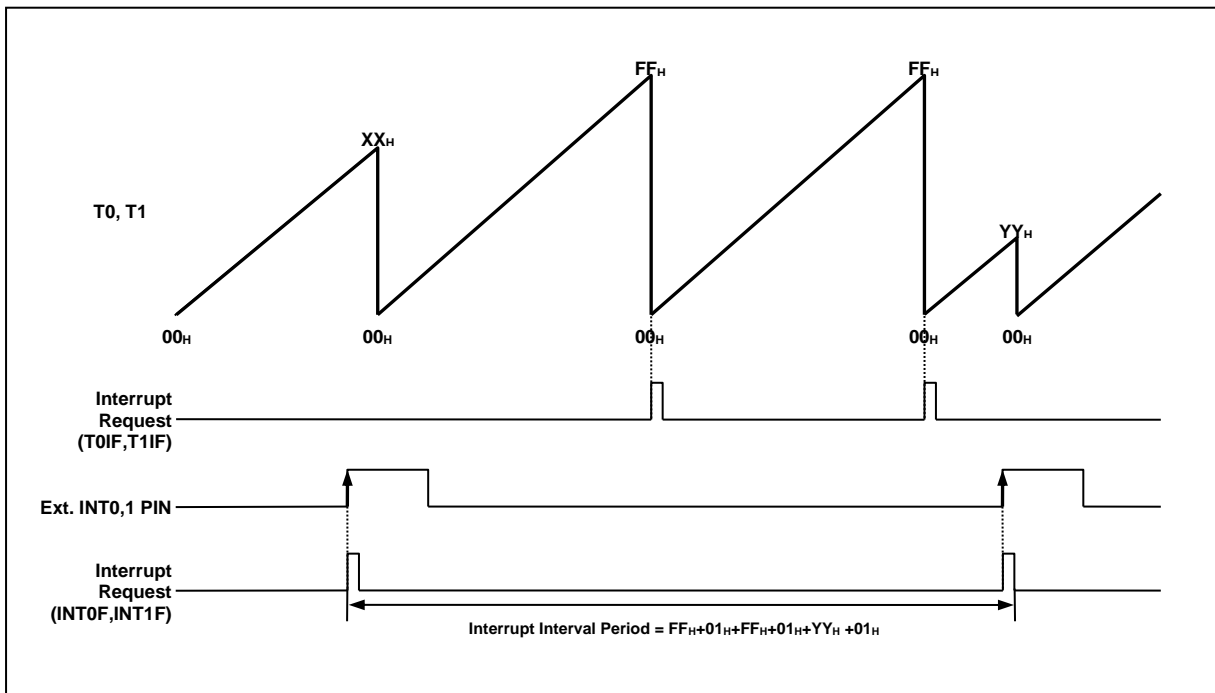

Figure 11.12 Express Timer Overflow in Capture Mode

### 11.5.1.5 16 Bit Capture Mode

The 16-bit capture mode is the same operation as 8-bit capture mode, except that the timer register uses 16 bits.

The clock source is selected from T0CK[2:0] and T1CK[1:0] must set 11b and 16BIT2 bit must set to '1'. The 16-bit mode setting is shown as Figure 11.13.

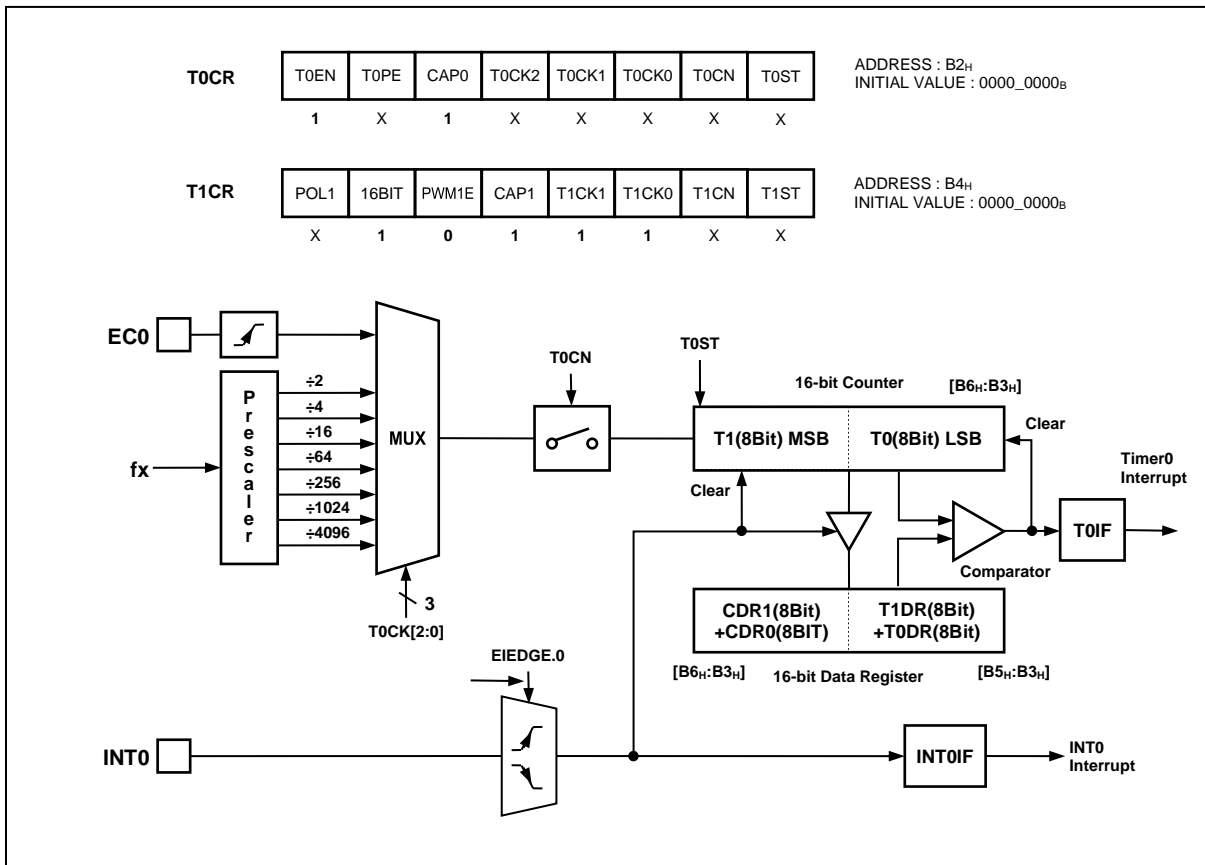

Figure 11.13 16-bit Capture Mode of Timer 0, 1

### 11.5.1.6 PWM Mode

The timer 1 has a PWM (pulse Width Modulation) function. In PWM mode, the T1/PWM1 output pin outputs up to 10-bit resolution PWM output. This pin should be configured as a PWM output by set T1\_PE to '1'. The period of the PWM output is determined by the T1PPR (PWM period register) + T1PWHR[3:2] + T1PWHR[1:0]

$$\text{PWM Period} = [ T1PWHR[3:2]T1PPR ] \times \text{Source Clock}$$

$$\text{PWM Duty} = [ T1PWHR[1:0] T1PDR ] \times \text{Source Clock}$$

Note> T1PPR must be set to higher than T1PDR for guaranteeing operation.

**Table 11-7 PWM Frequency vs. Resolution at 8 Mhz**

Resolution	Frequency		
	T1CK[1:0]=00 (125ns)	T1CK[1:0]=01 (250ns)	T1CK[1:0]=10 (2us)
10 Bit	7.8KHz	3.9KHz	0.49KHz
9 Bit	15.6KHz	7.8KHz	0.98KHz
8 Bit	31.2KHz	15.6KHz	1.95KHz
7 Bit	62.4KHz	31.2KHz	3.91KHz

The POL bit of T1CR register decides the polarity of duty cycle. If the duty value is set same to the period value, the PWM output is determined by the bit POL (1: High, 0: Low). And if the duty value is set to "00H", the PWM output is determined by the bit POL (1: Low, 0: High). PWM output is not retain high or low but toggle.

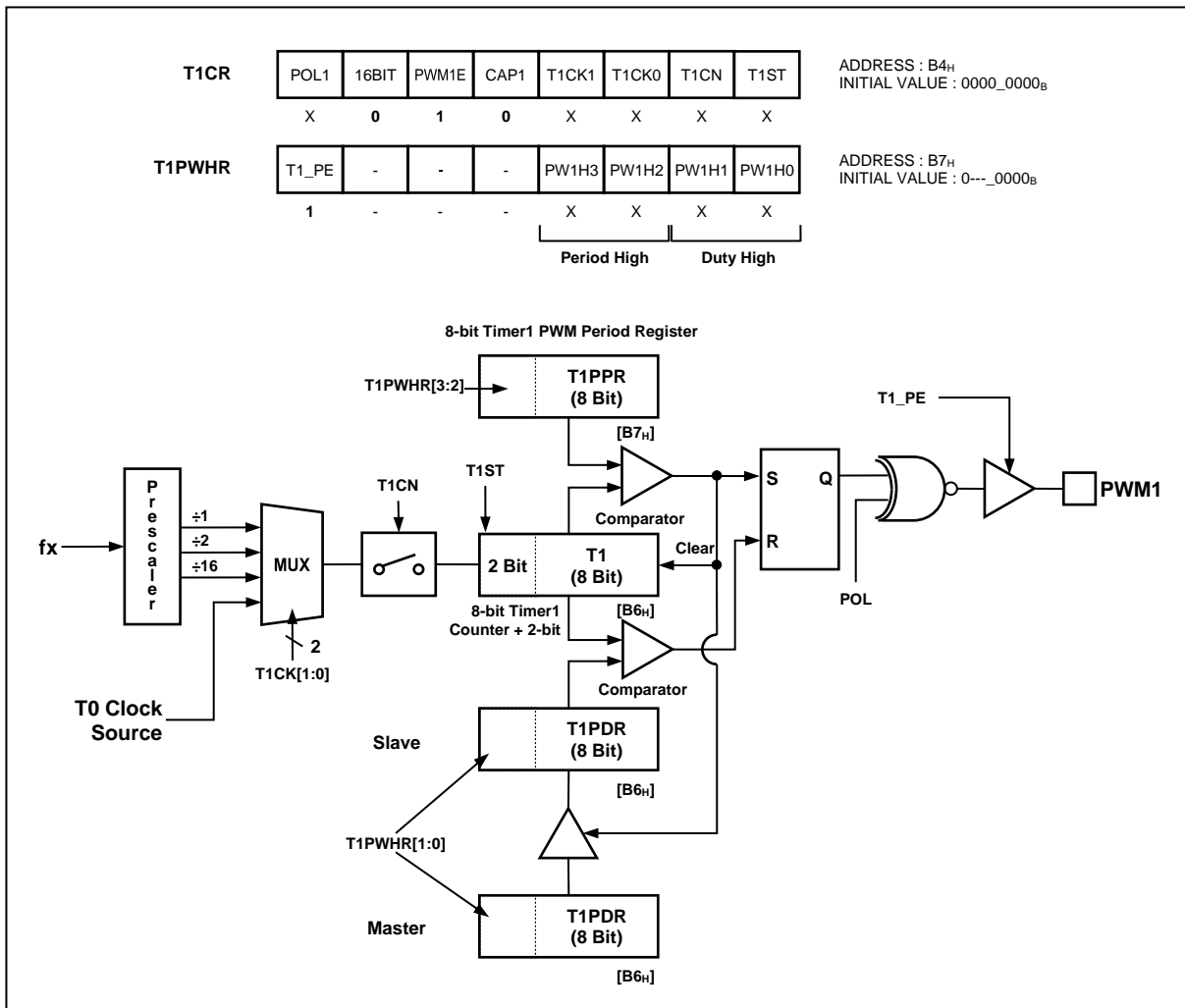

**Figure 11.14 PWM Mode**

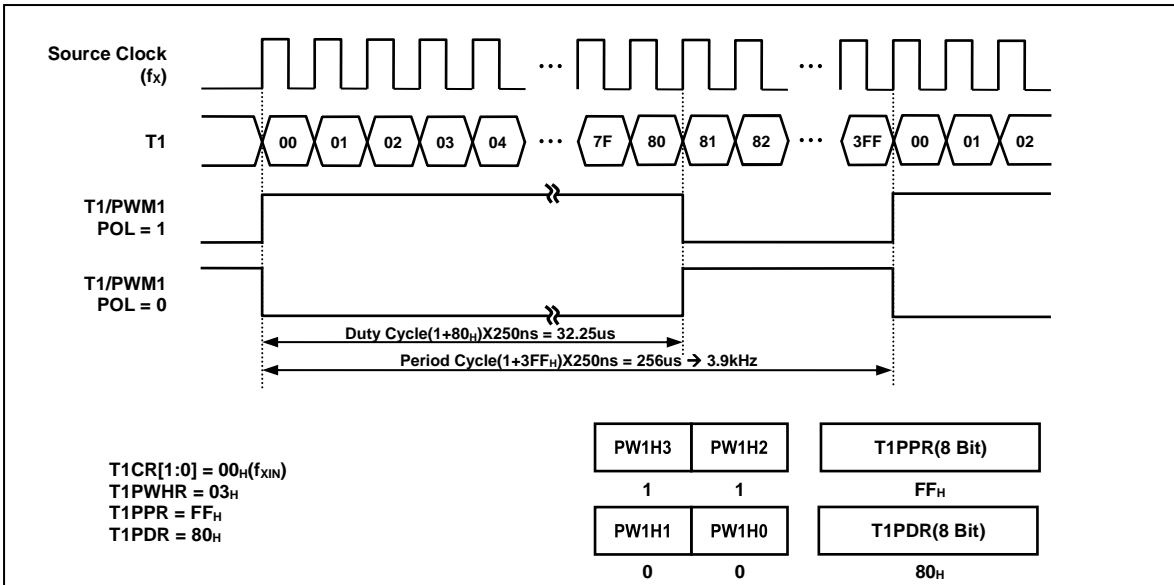

Figure 11.15 Example of PWM at 4MHz

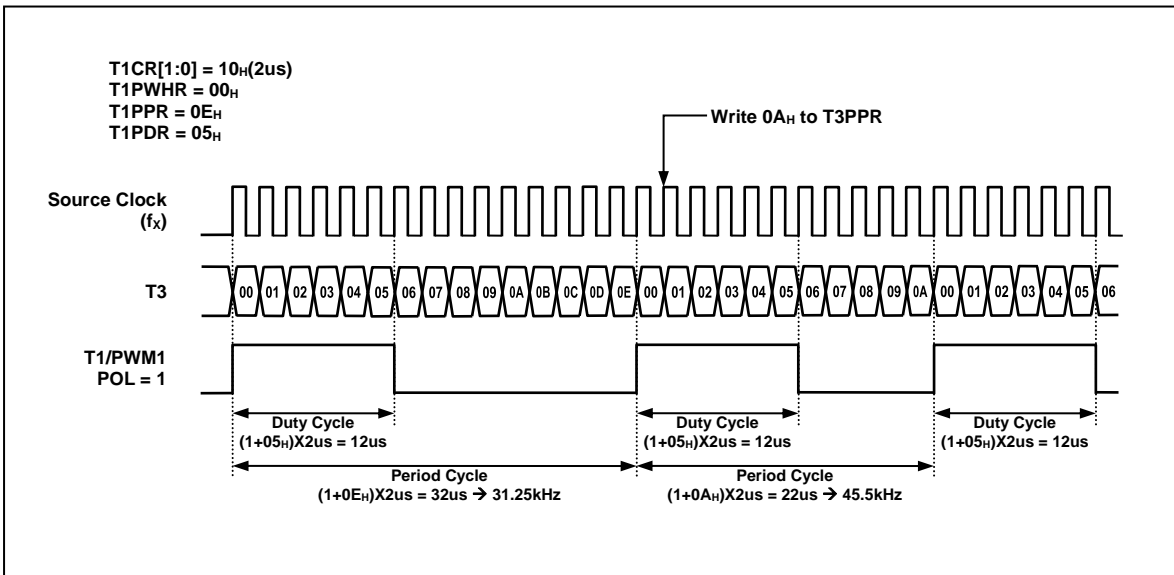

Figure 11.16 Example of Changing the Period in Absolute Duty Cycle at 4MHz

### 11.5.1.7 8-Bit (16 Bit) Compare Output Mode

If the T1 (T0+T1) value and the T1DR (T0DR+T1DR) value are matched, T1/PWM1 port outputs. The output is 50:50 of duty square wave, the frequency is following

$$f_{COMP} = \frac{\text{Oscillator Frequency}}{2 \times \text{Prescaler Value} \times (TDR + 1)}$$

To export the compare output as T1/PWM1, the T1\_PE bit in the T1PWHR register must set to '1'.

### 11.5.1.8 Register Map

Table 11-8 Register Map

Name	Address	Dir	Default	Description
T0CR	B2	R/W	00H	Timer 0 Mode Control Register
T0	B3	R	00H	Timer 0 Register
T0DR	B3	W	FFH	Timer 0 Data Register
CDR0	B3	R	00H	Capture 0 Data Register
T1CR	B4	R/W	00H	Timer 1 Mode Control Register
T1DR	B5	W	FFH	Timer 1 Data Register
T1PPR	B5	W	FFH	Timer 1 PWM Period Register
T1	B6	R	00H	Timer 1 Register
T1PDR	B6	R/W	00H	Timer 1 PWM Duty Register
CDR1	B6	R	00H	Capture 1 Data Register
T1PWHR	B7	W	00H	Timer 1 PWM High Register

### 11.5.1.9 Timer/Counter 0, 1 Register description

The Timer/Counter 0, 1 Register consists of Timer 0 Mode Control Register (T0CR), Timer 0 Register (T0), Timer 0 Data Register (T0DR), Capture 0 Data Register (CDR0), Timer 1 Mode Control Register (T1CR), Timer 1 Data Register (T1DR), Timer 1 PWM Period Register (T1PPR), Timer 1 Register (T1), Timer 1 PWM Duty Register (T1PDR), Capture 1 Data Register (CDR1) and Timer 1 PWM High Register (T1PWHR).



**11.5.1.10 Register description for Timer/Counter 0, 1**

**T0CR (Timer 0 Mode Control Register) : B2H**

7	6	5	4	3	2	1	0
T0EN	T0_PE	CAPO	T0CK2	T0CK1	T0CK0	T0CN	T0ST
RW	RW	RW	RW	RW	RW	RW	RW

Initial value : 00H

- T0EN** Control Timer 0
  - 0 Timer 0 disable
  - 1 Timer 0 enable
- T0\_PE** Control Timer 0 Output port
  - 0 Timer 0 Output disable
  - 1 Timer 0 Output enable
- CAPO** Control Timer 0 operation mode
  - 0 Timer/Counter mode
  - 1 Capture mode
- T0CK[2:0]** Select Timer 0 clock source. Fx is main system clock frequency
 

T0CK2	T0CK1	T0CK0	Description
0	0	0	fx/2
0	0	1	fx/4
0	1	0	fx/16
0	1	1	fx/64
1	0	0	fx/256
1	0	1	fx/1024
1	1	0	fx/4096
1	1	1	External Clock (EC0)
- T0CN** Control Timer 0 Count pause/continue
  - 0 Temporary count stop
  - 1 Continue count
- T0ST** Control Timer 0 start/stop
  - 0 Counter stop
  - 1 Clear counter and start

**T0 (Timer 0 Register: Read Case) : B3H**

7	6	5	4	3	2	1	0
T07	T06	T05	T04	T03	T02	T01	T00
R	R	R	R	R	R	R	R

Initial value : 00H

**T0[7:0]** T0 Counter data

**T0DR (Timer 0 Data Register: Write Case) : B3H**

7	6	5	4	3	2	1	0
T0D7	T0D6	T0D5	T0D4	T0D3	T0D2	T0D1	T0D0
W	W	W	W	W	W	W	W

Initial value : FFH

**T0D[7:0]** T0 Compare data

**CDR0 (Capture 0 Data Register: Read Case) : B3H**

7	6	5	4	3	2	1	0
CDR07	CDR06	CDR05	CDR04	CDR03	CDR02	CDR01	CDR00
R	R	R	R	R	R	R	R

Initial value : 00H

**CDR0[7:0]** T0 Capture data

**T1CR (Timer 1 Mode Count Register) : B4H**

7	6	5	4	3	2	1	0
POL	16BIT	PWM1E	CAP1	T1CK1	T1CK0	T1CN	T1ST
R/W	R/W	R/W	R/W	R/W	R/W	R/W	R/W

Initial value : 00H

**POL** Configure PWM polarity

0 Negative (Duty Match: Clear)

1 Positive (Duty Match: Set)

**16BIT** Select Timer 1 8/16Bit

0 8 Bit

1 16 Bit

**PWM1E** Control PWM enable

0 PWM disable

1 PWM enable

**CAP1** Control Timer 1 mode

0 Timer/Counter mode

1 Capture mode

**T1CK[1:0]** Select clock source of Timer 1. Fx is the frequency of main system.

T1CK1	T1CK0	description
0	0	fx
0	1	fx/2
1	0	fx/16
1	1	Use Timer 0 Clock

**T1CN** Control Timer 1 Count pause/continue

0 Temporary count stop

1 Continue count

**T1ST** Control Timer 1 start/stop

0 Counter stop

1 Clear counter and start

**T1DR (Timer 1 Data Register: Write Case) : B5H**

7	6	5	4	3	2	1	0
T1D7	T1D6	T1D5	T1D4	T1D3	T1D2	T1D1	T1D0
W	W	W	W	W	W	W	W

Initial value : FFH

**T1D[7:0]** T1 Compare data

**T1PPR (Timer 1 PWM Period Register: Write Case PWM mode only) : B5H**

7	6	5	4	3	2	1	0
T1PP7	T1PP6	T1PP5	T1PP4	T1PP3	T1PP2	T1PP1	T1PP0
W	W	W	W	W	W	W	W

Initial value : FFH

**T1PP[7:0]** T1 PWM Period data

**T1 (Timer 1 Register: Read Case) : B6H**

7	6	5	4	3	2	1	0
T17	T16	T15	T14	T13	T12	T11	T10
R	R	R	R	R	R	R	R

Initial value : 00H

**T1[7:0]** T1 Counter Period data

**T1PDR (Timer 1 PWM Duty Register) : B6H**

7	6	5	4	3	2	1	0
T1PD7	T1PD6	T1PD5	T1PD4	T1PD3	T1PD2	T1PD1	T1PD0
RW	RW	RW	RW	RW	RW	RW	RW

Initial value : 00H

**T1PD[7:0]** T1 PWM Duty data  
 Note) only write, when PWM1E '1'

**CDR1 (Capture 1 Data Register: Read Case) : B6H**

7	6	5	4	3	2	1	0
CDR17	CDR16	CDR15	CDR14	CDR13	CDR12	CDR11	CDR10
R	R	R	R	R	R	R	R

Initial value : 00H

**CDR3[7:0]** T1 Capture data

**T1PWHR (Timer 1 PWM High Register) : B7H**

7	6	5	4	3	2	1	0
T1_PE	-	-	-	PW3H3	PW3H2	PW3H1	PW3H0
W	-	-	-	W	W	W	W

Initial value : 00H

**T1\_PE** Control Timer 1 Output port operation  
 Note) only writable Bit. Be careful  
 0 Timer 1 Output disable  
 1 Timer 1 Output enable

**PW1H[3:2]** PWM period High value (Bit [9:8])

**PW1H[1:0]** PWM duty High value (Bit [9:8])

PERIOD:	PW1H3	PW1H2	T1PPR[7:0]
DUTY:	PW1H1	PW1H0	T1PDR[7:0]

## 11.5.2 16-bit Timer/Event Counter 2, 3, 4, 5

### 11.5.2.1 Overview

The 16-bit timer x(2~5) consists of Multiplexer, Timer Data Register High/Low, Timer Register High/Low, Timer Mode Control Register, PWM Duty High/Low, PWM Period High/Low Register. It is able to use internal 16-bit timer/ counter without a port output function.

The 16-bit timer x is able to use the divided clock of the main clock selected from prescaler output.

#### 11.5.2.2 16-Bit Timer/Counter Mode

In the 16-bit Timer/Counter Mode, If the TxH + TxL value and the TxDRH + TxDRL value are matched, T3/PWM3 port outputs. The output is 50:50 of duty square wave, the frequency is following

$$f_{COMP} = \frac{\text{Timer Clock Frequency}}{2 \times \text{Prescaler Value} \times (TxDR + 1)}$$

$f_{COMP}$  is timer output frequency and TxDR is the 16 bits value of TxDRH and TxDRL.

To export the compare output as Tx/PWMx, the Tx\_PE bit in the TxCR1 register must set to '1'.

The 16-bit Timer/Counter Mode is selected by control registers as shown in Figure 11.17 Timerx 16-bit Mode Block Diagram

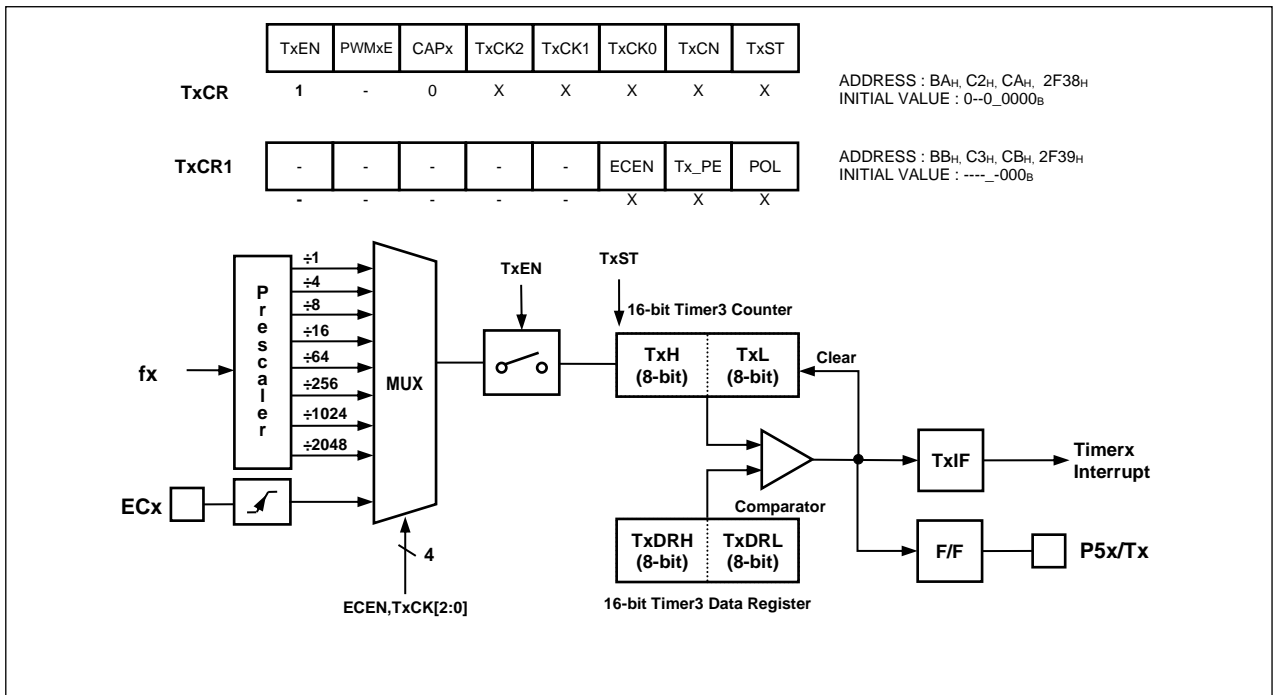

Figure 11.17 Timerx 16-bit Mode Block Diagram

### 11.5.2.3 16-Bit Capture Mode

The timer X(2~5) capture mode is set by CAPx as '1' in TxCR register. The clock is same source as Output Compare mode. The interrupt occurs at TxH, TxL and TxDRH, TxDRL matching time. The capture result is loaded into CDRxH, CDRxL. The TxH, TxL value is automatically cleared(0000<sub>H</sub>) by hardware and restarts counter.

This timer interrupt in capture mode is very useful when the pulse width of captured signal is wide

Figure 11-26 8 Bit Timer/Event Counter2, 3 Block Diagram

r than the maximum period of timer. As the EIEDGE and EIPOLA register setting, the external interrupt INTx function is chosen.

The CDRxH, PWMxHDR and TxH are in same address. In the capture mode, reading operation is read the CDRxH, not TxH because path is opened to the CDRxH. PWMxHDR will be changed in writing operation. The PWMxLDR, TxL, CDRxL has the same function.

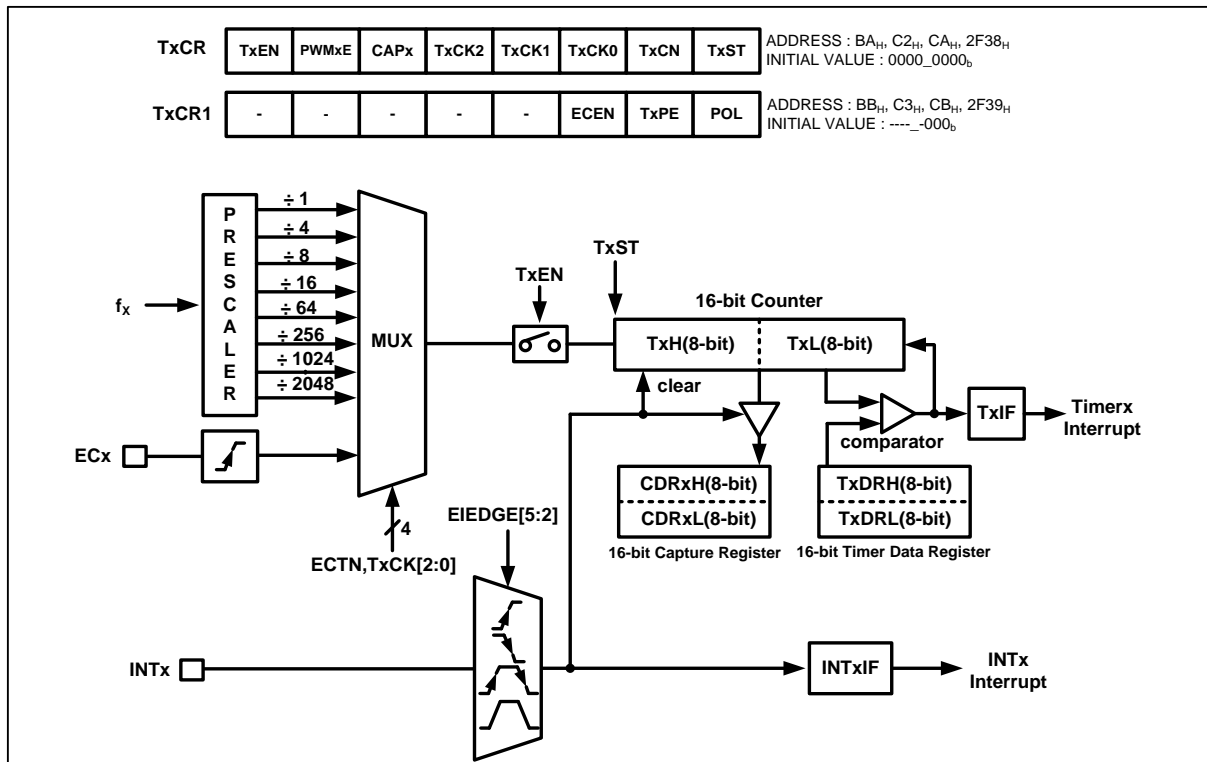

Figure 11.18 16-bit Capture Mode of Timer x

### 11.5.2.4 PWM Mode

The timer X(2~5) has a PWM (pulse Width Modulation) function. In PWM mode, the TX/PWMX output pin outputs up to 16-bit resolution PWM output. This pin should be configured as a PWM output by set TX\_PE to '1'. The PWM output mode is determined by the PWMxHPR, PWMxLPR, PWMxHDR and PWMxLDR. And you should configure PWMxE bit to "1" in TxCR register

$$\text{PWM Period} = [ \text{PWMxHPR}, \text{PWMxLPR} ] \times \text{Source Clock}$$

$$\text{PWM Duty} = [ \text{PWMxHDR}, \text{PWMxLDR} ] \times \text{Source Clock}$$

Table 11-9 PWM Frequency vs. Resolution at 8 Mhz

Resolution	Frequency		
	TxCK[2:0]=000 (125ns)	TxCK[2:0]=010 (500ns)	TxCK[2:0]=011 (1us)
16-bit	122.070Hz	30.469Hz	15.259Hz
15-bit	244.141Hz	60.938Hz	30.518Hz
10-bit	7.8125KHz	1.95KHz	976.563Hz
9-bit	15.625KHz	3.9KHz	1.953KHz
8-bit	31.25KHz	7.8KHz	3.906KHz

The POL bit of TxCR register decides the polarity of duty cycle. If the duty value is set same to the period value, the PWM output is determined by the bit POL (1: High, 0: Low). And if the duty value is set to "00H", the PWM output is determined by the bit POL (1: Low, 0: High).

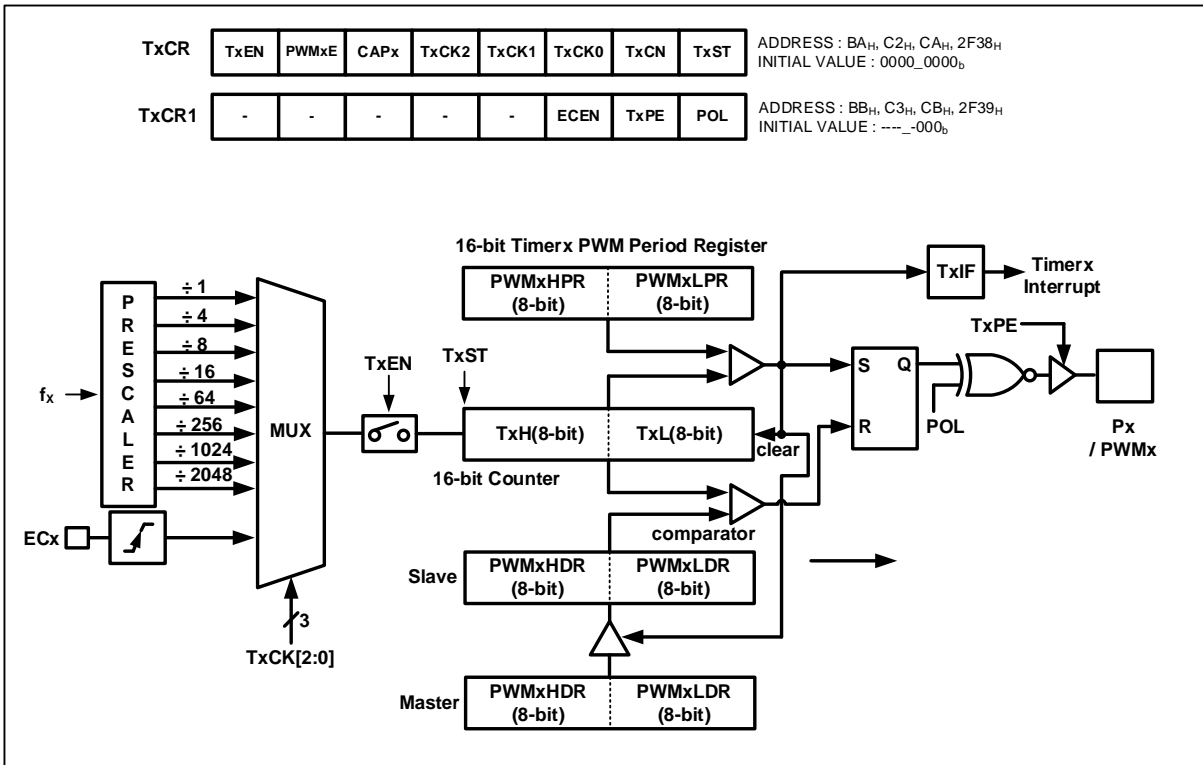

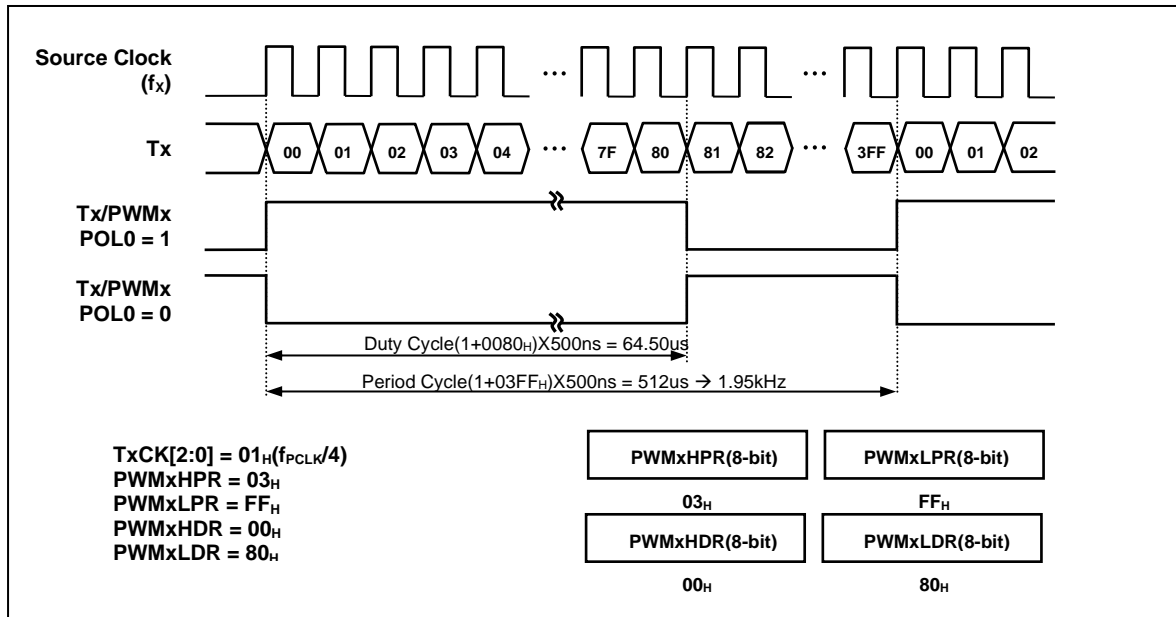

Figure 11.20 Example of PWM at 8MHz

### 11.5.2.5 Register Map

Table 11-10 Register Map

Name	Address	Dir	Default	Description
T2CR	BA <sub>H</sub>	R/W	00 <sub>H</sub>	Timer 2 Mode Control Register
T2CR1	BB <sub>H</sub>	R/W	00 <sub>H</sub>	Timer 2 Mode Control Register 1
T2L	BC <sub>H</sub>	R	00 <sub>H</sub>	Timer 2 Low Register
PWM2LDR	BC <sub>H</sub>	R/W	00 <sub>H</sub>	PWM 2 Duty Low Register
CDR2L	BC <sub>H</sub>	R	00 <sub>H</sub>	Timer 2 Capture Data Low Register
T2H	BD <sub>H</sub>	R	00 <sub>H</sub>	Timer 2 High Register
PWM2HDR	BD <sub>H</sub>	R/W	00 <sub>H</sub>	PWM 2 Duty High Register
CDR2H	BD <sub>H</sub>	R	00 <sub>H</sub>	Timer 2 Capture Data High Register
T2DRL	BE <sub>H</sub>	W	FF <sub>H</sub>	Timer 2 Data Register Low
PWM2LPR	BE <sub>H</sub>	W	FF <sub>H</sub>	PWM 2 Period Low Register
T2DRH	BF <sub>H</sub>	W	FF <sub>H</sub>	Timer 2 Data Register High
PWM2HPR	BF <sub>H</sub>	W	FF <sub>H</sub>	PWM 2 Period High Data Register
T3CR	C2 <sub>H</sub>	R/W	00 <sub>H</sub>	Timer 3 Mode Control Register
T3CR1	C3 <sub>H</sub>	R/W	00 <sub>H</sub>	Timer 3 Mode Control Register 1
T3L	C4 <sub>H</sub>	R	00 <sub>H</sub>	Timer 3 Low Register
PWM3LDR	C4 <sub>H</sub>	R/W	00 <sub>H</sub>	PWM 3 Duty Low Register
CDR3L	C4 <sub>H</sub>	R	00 <sub>H</sub>	Timer 3 Capture Data Low Register
T3H	C5 <sub>H</sub>	R	00 <sub>H</sub>	Timer 3 High Register
PWM3HDR	C5 <sub>H</sub>	R/W	00 <sub>H</sub>	PWM 3 Duty High Register
CDR3H	C5 <sub>H</sub>	R	00 <sub>H</sub>	Timer 3 Capture Data High Register
T3DRL	C6 <sub>H</sub>	W	FF <sub>H</sub>	Timer 3 Data Register Low
PWM3LPR	C6 <sub>H</sub>	W	FF <sub>H</sub>	PWM 3 Period Low Register



T3DRH	C7 <sub>H</sub>	W	FF <sub>H</sub>	Timer 3 Data Register High
PWM3HPR	C7 <sub>H</sub>	W	FF <sub>H</sub>	PWM 3 Period High Data Register
T4CR	CA <sub>H</sub>	R/W	00 <sub>H</sub>	Timer 4 Mode Control Register
T4CR1	CB <sub>H</sub>	R/W	00 <sub>H</sub>	Timer 4 Mode Control Register 1
T4L	CC <sub>H</sub>	R	00 <sub>H</sub>	Timer 4 Low Register
PWM4LDR	CC <sub>H</sub>	R/W	00 <sub>H</sub>	PWM 4 Duty Low Register
CDR4 L	CC <sub>H</sub>	R	00 <sub>H</sub>	Timer 4 Capture Data Low Register
T4 H	CD <sub>H</sub>	R	00 <sub>H</sub>	Timer 4 High Register
PWM4 HDR	CD <sub>H</sub>	R/W	00 <sub>H</sub>	PWM 4 Duty High Register
CDR4 H	CD <sub>H</sub>	R	00 <sub>H</sub>	Timer 4 Capture Data High Register
T4 LDR	CE <sub>H</sub>	W	FF <sub>H</sub>	Timer 4 Data Register Low
PWM4 LPR	CE <sub>H</sub>	W	FF <sub>H</sub>	PWM 4 Period Low Register
T4 HDR	CF <sub>H</sub>	W	FF <sub>H</sub>	Timer 4 Data Register High
PWM4 HPR	CF <sub>H</sub>	W	FF <sub>H</sub>	PWM 4 Period High Data Register
T5CR	2F38 <sub>H</sub>	R/W	00 <sub>H</sub>	Timer 5 Mode Control Register
T5CR1	2F39 <sub>H</sub>	R/W	00 <sub>H</sub>	Timer 5 Mode Control Register 1
T5L	2F3A <sub>H</sub>	R	00 <sub>H</sub>	Timer 5 Low Register
PWM5LDR	2F3A <sub>H</sub>	R/W	00 <sub>H</sub>	PWM 5 Duty Low Register
CDR5L	2F3A <sub>H</sub>	R	00 <sub>H</sub>	Timer 5 Capture Data Low Register
T5H	2F3B <sub>H</sub>	R	00 <sub>H</sub>	Timer 5 High Register
PWM5HDR	2F3B <sub>H</sub>	R/W	00 <sub>H</sub>	PWM 5 Duty High Register
CDR5H	2F3B <sub>H</sub>	R	00 <sub>H</sub>	Timer 5 Capture Data High Register
T5DRL	2F3C <sub>H</sub>	W	FF <sub>H</sub>	Timer 5 Data Register Low
PWM5LPR	2F3C <sub>H</sub>	W	FF <sub>H</sub>	PWM 5 Period Low Register
T5DRH	2F3D <sub>H</sub>	W	FF <sub>H</sub>	Timer 5 Data Register High
PWM5HPR	2F3D <sub>H</sub>	W	FF <sub>H</sub>	PWM 5 Period High Data Register

### 11.5.2.6 Timer/Counter x Register description

The Timer 2~5 Register consists of Timer 2~5 Mode Control Register (T2CR), (T3CR), (T4CR), (T5CR), Timer 2~5 Mode Control Register 1 (T2CR1), (T3CR1), (T4CR1), (T5CR1), Timer 2~5 Low Register (T2L), (T3L), (T4L), (T5L), Timer 2~5 Data Register Low (T2DRL), (T3DRL), (T4DRL), (T5DRL), Timer 2~5 High Register (T2H), (T3H), (T4H), (T5H), Timer 2~5 Data Register High (T2DRH), (T3DRH), (T4DRH), (T5DRH), Timer 2~5 Capture Data Low Register (CDR2L), (CDR3L), (CDR4L), (CDR5L), Timer 2~5 Capture Data High Register (CDR2H), (CDR3H), (CDR4H), (CDR5H), PWM2~5 Low Duty Register (PWM2LDR), (PWM3LDR), (PWM4LDR), (PWM5LDR), PWM2~5 High Duty Register (PWM2HDR), (PWM3HDR), (PWM4HDR), (PWM5HDR), PWM2~5 Low Period Register (PWM2LPR), (PWM3LPR), (PWM4LPR), (PWM5LPR), PWM2~5 High Period Register (PWM2HPR), (PWM3HPR), (PWM4HPR), (PWM5HPR).

## 11.5.2.7 Register description for Timer/Counter 2~5

**T2CR, T3CR, T4CR, T5CR (Timer 2~5 Mode Control Register): BAH, C2H, CAH, 2F38H**

7	6	5	4	3	2	1	0
TxEN	PWMxE	CAPx	TxCK2	TxCK1	TxCK0	TxCN	TxST
RW	RW	RW	RW	RW	RW	RW	RW

Initial value : 00H

<b>TxEN</b>	Control Timer X			
	0	0		
	1	Timer X enable		
<b>PWMxE</b>	Control PWM enable			
	0	PWM disable		
	1	PWM enable		
<b>CAPx</b>	Control Timer X capture mode.			
	0	Timer/Counter mode		
	1	Capture mode		
<b>TxCK[2:0]</b>	Select clock source of Timer X. Fx is the frequency of main system			
	TxCK2	TxCK1	TxCK0	description
	0	0	0	fx
	0	0	1	fx /4
	0	1	0	fx /8
	0	1	1	fx /16
	1	0	0	fx /64
	1	0	1	fx /256
	1	1	0	fx /1024
	1	1	1	fx /2048
<b>TxCN</b>	Control Timer X Count pause/continue.			
	0	Temporary count stop		
	1	Continue count		
<b>TxST</b>	Control Timer X start/stop			
	0	Counter stop		
	1	Clear counter and start		

**T2CR1, T3CR1, T4CR1, T5CR1 (Timer 2~5 Mode Control Register 1) : BBH, C3H, CBH, 2F39H**

7	6	5	4	3	2	1	0
-	-	-	-	-	ECEN	Tx_PE	POL
-	-	-	-	-	RW	RW	RW

Initial value : 00H

<b>ECEN</b>	Control Timer X External Clock			
	0	Timer X External Clock disable		
	1	Timer X External Clock enable		
<b>Tx_PE</b>	Control Timer X Output port			
	0	Timer X Output disable		

- 1 Timer X Output enable
- POL** Configure PWM polarity
- 0 Negative (Duty Match: Clear)
- 1 Positive (Duty Match: Set)

**T2L, T3L, T4L, T5L (Timer 2~5 Low Register, Read Case) : BCH, C4H, CCH, 2F3AH**

7	6	5	4	3	2	1	0
TxL7	TxL6	TxL5	TxL4	TxL3	TxL2	TxL1	TxL0
R	R	R	R	R	R	R	R

Initial value : 00<sub>H</sub>

**TxL[7:0]** TxL Counter Period Low data.

**CDR2L, CDR3L, CDR4L, CDR5L (Capture 2~5 Data Low Register, Read Case) : BCH, C4H, CCH, 2F3AH**

7	6	5	4	3	2	1	0
CDRxL07	CDRxL06	CDRxL05	CDRxL04	CDRxL03	CDRxL02	CDRxL01	CDRxL00
R	R	R	R	R	R	R	R

Initial value : 00<sub>H</sub>

**CDRxL[7:0]** Tx Capture Low data.

**PWM2LDR, PWM3LDR, PWM4LDR, PWM5LDR (PWM 2~5 Low Duty Register, Write Case) : BCH, C4H, CCH, 2F3AH**

7	6	5	4	3	2	1	0
PWMxLD7	PWMxLD6	PWMxLD5	PWMxLD4	PWMxLD3	PWMxLD2	PWMxLD1	PWMxLD0
W	W	W	W	W	W	W	W

Initial value : 00<sub>H</sub>

**PWMxLD[7:0]** Tx PWM Duty Low data  
Note) only write, when PWMxE '1'

**T2H, T3H, T4H, T5H (Timer 2~5 High Register, Read Case) : BDH, C5H, CDH, 2F3BH**

7	6	5	4	3	2	1	0
TxH7	TxH6	TxH5	TxH4	TxH3	TxH2	TxH1	TxH0
R	R	R	R	R	R	R	R

Initial value : 00<sub>H</sub>

**TxH[7:0]** TxH Counter Period High data.

**CDR2H, CDR3H, CDR4H, CDR5H (Capture 2~5 Data High Register, Read Case) : BDH, C5H, CDH, 2F3BH**

7	6	5	4	3	2	1	0
CDRxH07	CDRxH06	CDRxH05	CDRxH04	CDRxH03	CDRxH02	CDRxH01	CDRxH00
R	R	R	R	R	R	R	R

Initial value : 00<sub>H</sub>

**CDRxH[7:0]** Tx Capture High data

**PWM2HDR, PWM3HDR, PWM4HDR, PWM5HDR (PWM 2~5 High Duty Register, Write Case) : BDH, C5H, CDH, 2F3BH**

7	6	5	4	3	2	1	0
PWMxHD7	PWMxHD6	PWMxHD5	PWMxHD4	PWMxHD3	PWMxHD2	PWMxHD1	PWMxHD0
W	W	W	W	W	W	W	W

Initial value : 00<sub>H</sub>

**PWMxHD[7:0]** Tx PWM Duty High data  
Note) only write, when PWMxE '1'

**T2DRL, T3DRL, T4DRL, T5DRL (Timer 2~5 Data Register Low, Write Case) : BEH, C6H, CEH, 2F3CH**

7	6	5	4	3	2	1	0
TxLD7	TxLD6	TxLD5	TxLD4	TxLD3	TxLD2	TxLD1	TxLD0
W	W	W	W	W	W	W	W

Initial value : FF<sub>H</sub>

**TxLD[7:0]** TxL Compare Low data

**PWM2LPR, PWM3LPR, PWM4LPR, PWM5LPR (PWM 2~5 Low Period Register, Write Case) : BEH, C6H, CEH, 2F3CH**

7	6	5	4	3	2	1	0
PWMxLP7	PWMxLP6	PWMxLP5	PWMxLP4	PWMxLP3	PWMxLP2	PWMxLP1	PWMxLP0
W	W	W	W	W	W	W	W

Initial value : FF<sub>H</sub>

**PWMxLP[7:0]** Tx PWM Duty Low data  
Note) only write, when PWMxE '1'

**T2DRH, T3DRH, T4DRH, T5DRH (Timer 2~5 Data Register High, Write Case) : BFH, C7H, CFH, 2F3DH**

7	6	5	4	3	2	1	0
TxHD7	TxHD6	TxHD5	TxHD4	TxHD3	TxHD2	TxHD1	TxHD0
W	W	W	W	W	W	W	W

Initial value : FF<sub>H</sub>

**TxHD[7:0]** TxH Compare High data

**PWM2HPR, PWM3HPR, PWM4HPR, PWM5HPR (PWM 2~5 High Period Register, Write Case) : BFH, C7H, CFH, 2F3DH**

7	6	5	4	3	2	1	0
PWMxHP7	PWMxHP6	PWMxHP5	PWMxHP4	PWMxHP3	PWMxHP2	PWMxHP1	PWMxHP0
W	W	W	W	W	W	W	W

Initial value : FF<sub>H</sub>

**PWMxHP[7:0]** Tx PWM Duty High data  
Note) only write, when PWMxE '1'.

### 11.5.3 Timer Interrupt Status Register (TMISR)

#### 11.5.3.1 Register description for TMISR

**TMISR (Timer Interrupt Status Register) : D5H**

7	6	5	4	3	2	1	0
-	-	TMIF5	TMIF4	TMIF3	TMIF2	TMIF1	TMIF0
-	-	R	R	R	R	R	R

Initial value : 00H

<b>TMIF5</b>	Timer 5 Interrupt Flag
0	No Timer 5 interrupt
1	Timer 5 interrupt occurred, write "1" to clear interrupt flag
<b>TMIF4</b>	Timer 4 Interrupt Flag
0	No Timer 4 interrupt
1	Timer 4 interrupt occurred, write "1" to clear interrupt flag
<b>TMIF3</b>	Timer 3 Interrupt Flag
0	No Timer 3 interrupt
1	Timer 3 interrupt occurred, write "1" to clear interrupt flag
<b>TMIF2</b>	Timer 2 Interrupt Flag
0	No Timer 2 interrupt
1	Timer 2 interrupt occurred, write "1" to clear interrupt flag
<b>TMIF1</b>	Timer 1 Interrupt Flag
0	No Timer 1 interrupt
1	Timer 1 interrupt occurred, write "1" to clear interrupt flag
<b>TMIF0</b>	Timer 0 Interrupt Flag
0	No Timer 0 interrupt
1	Timer 0 interrupt occurred, write "1" to clear interrupt flag

Note) The Timer Interrupt Status Register contains interrupt information of each timers. Even if user disabled timer interrupt at IE2, user could check timer interrupt condition from this register.

## 11.6 Buzzer Driver

### 11.6.1 Overview

The Buzzer consists of 8 Bit Counter and BUZDR (Buzzer Data Register), BUZCR (Buzzer Control Register). The Square Wave (61.035Hz~125 KHz, @8MHz) gets out of P12/BUZ pin. BUZDR (Buzzer Data Register) controls the Buzzer frequency (look at the following expression). In the BUZCR (Buzzer Control Register), BUCK[1:0] selects source clock divided from prescaler.

$$f_{BUZ}(Hz) = \frac{\text{Oscillator Frequency}}{2 \times \text{Prescaler Ratio} \times (\text{BUZDR} + 1)}$$

**Table 11-11 Buzzer Frequency at 8MHz**

BUZDR[7:0]	Buzzer Frequency (kHz)			
	BUZCR[2:1]=00	BUZCR[2:1]=01	BUZCR[2:1]=10	BUZCR[2:1]=11
0000_0000	125kHz	62.5kHz	31.25kHz	15.625kHz
0000_0001	62.5kHz	31.25kHz	15.625kHz	7.812kHz
...	...	...	...	...
1111_1101	492.126Hz	246.063Hz	123.031Hz	61.515Hz
1111_1110	490.196Hz	245.098Hz	122.549Hz	61.274Hz
1111_1111	488.281Hz	244.141Hz	122.07Hz	61.035Hz

### 11.6.2 Block Diagram

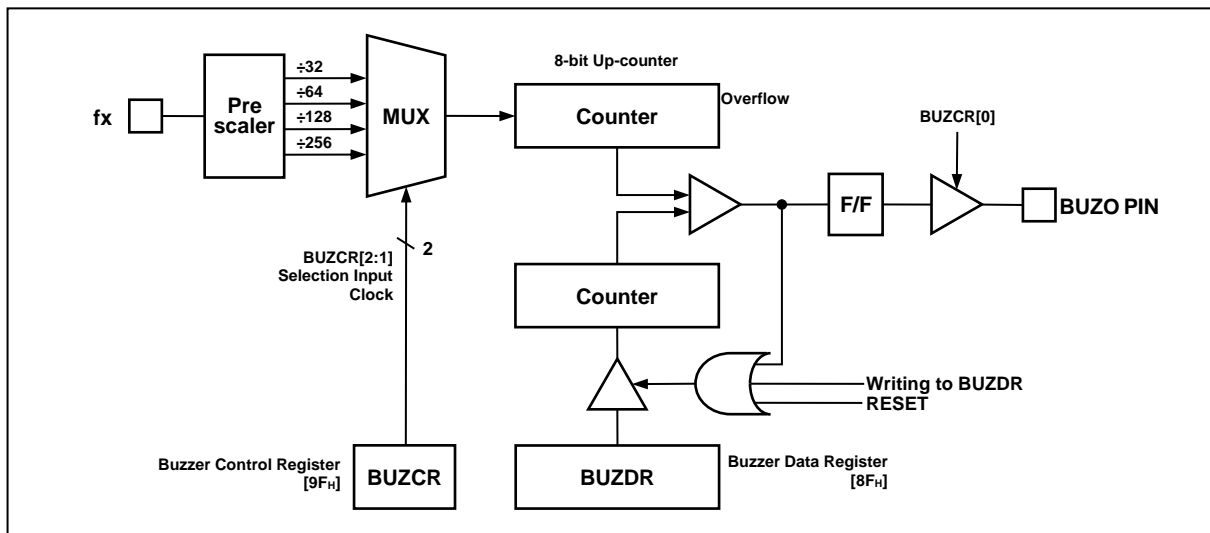

**Figure 11.21 Buzzer Driver Block Diagram**

### 11.6.3 Register Map

Table 11-12 Register Map

Name	Address	Dir	Default	Description
BUZDR	8FH	R/W	FFH	Buzzer Data Register
BUZCR	9FH	R/W	00H	Buzzer Control Register

### 11.6.4 Buzzer Driver Register description

Buzzer Driver consists of Buzzer Data Register (BUZDR), Buzzer Control Register (BUZCR).

### 11.6.5 Register description for Buzzer Driver

#### BUZDR (Buzzer Data Register) : 8FH

7	6	5	4	3	2	1	0
BUZDR7	BUZDR6	BUZDR5	BUZDR4	BUZDR3	BUZDR2	BUZDR1	BUZDR0
R/W	R/W	R/W	R/W	R/W	R/W	R/W	R/W

Initial value : FFH

**BUZDR[7:0]** This bits control the Buzzer frequency  
Its resolution is 00H ~ FFH

#### BUZCR (Buzzer Control Register) : 9FH

7	6	5	4	3	2	1	0
-	-	-	-	-	BUCK1	BUCK0	BUZEN
-	-	-	-	-	R/W	R/W	R/W

Initial value : 00H

**BUCK[1:0]** Buzzer Driver Source Clock Selection

BUCK1	BUCK0	Source Clock
0	0	fx/32
0	1	fx/64
1	0	fx/128
1	1	fx/256

**BUZEN** Buzzer Driver Operation Control

BUZEN	Operation
0	Buzzer Driver disable
1	Buzzer Driver enable

Note) fx: Main system clock oscillation frequency

## 11.7 USART

### 11.7.1 Overview

The Universal Synchronous and Asynchronous serial Receiver and Transmitter (USART) is a highly flexible serial communication device. The main features are listed below.

- Full Duplex Operation (Independent Serial Receive and Transmit Registers)
- Asynchronous or Synchronous Operation
- Master or Slave Clocked Synchronous and SPI Operation
- Supports all four SPI Modes of Operation (Mode 0, 1, 2, 3)
- LSB First or MSB First Data Transfer @SPI mode
- High Resolution Baud Rate Generator
- Supports Serial Frames with 5,6,7,8, or 9 Data Bits and 1 or 2 Stop Bits
- Odd or Even Parity Generation and Parity Check Supported by Hardware
- Data OverRun Detection
- Framing Error Detection
- Digital Low Pass Filter
- Three Separate Interrupts on TX Complete, TX Data Register Empty and RX Complete
- Double Speed Asynchronous Communication Mode

USART has three main parts of Clock Generator, Transmitter and Receiver. The Clock Generation logic consists of synchronization logic for external clock input used by synchronous or SPI slave operation, and the baud rate generator for asynchronous or master (synchronous or SPI) operation. The Transmitter consists of a single write buffer, a serial shift register, parity generator and control logic for handling different serial frame formats. The write buffer allows a continuous transfer of data without any delay between frames. The receiver is the most complex part of the USART module due to its clock and data recovery units. The recovery unit is used for asynchronous data reception. In addition to the recovery unit, the Receiver includes a parity checker, a shift register, a two level receive FIFO (UDATAx) and control logic. The Receiver supports the same frame formats as the Transmitter and can detect Frame Error, Data OverRun and Parity Errors.



11.7.2 Block Diagram

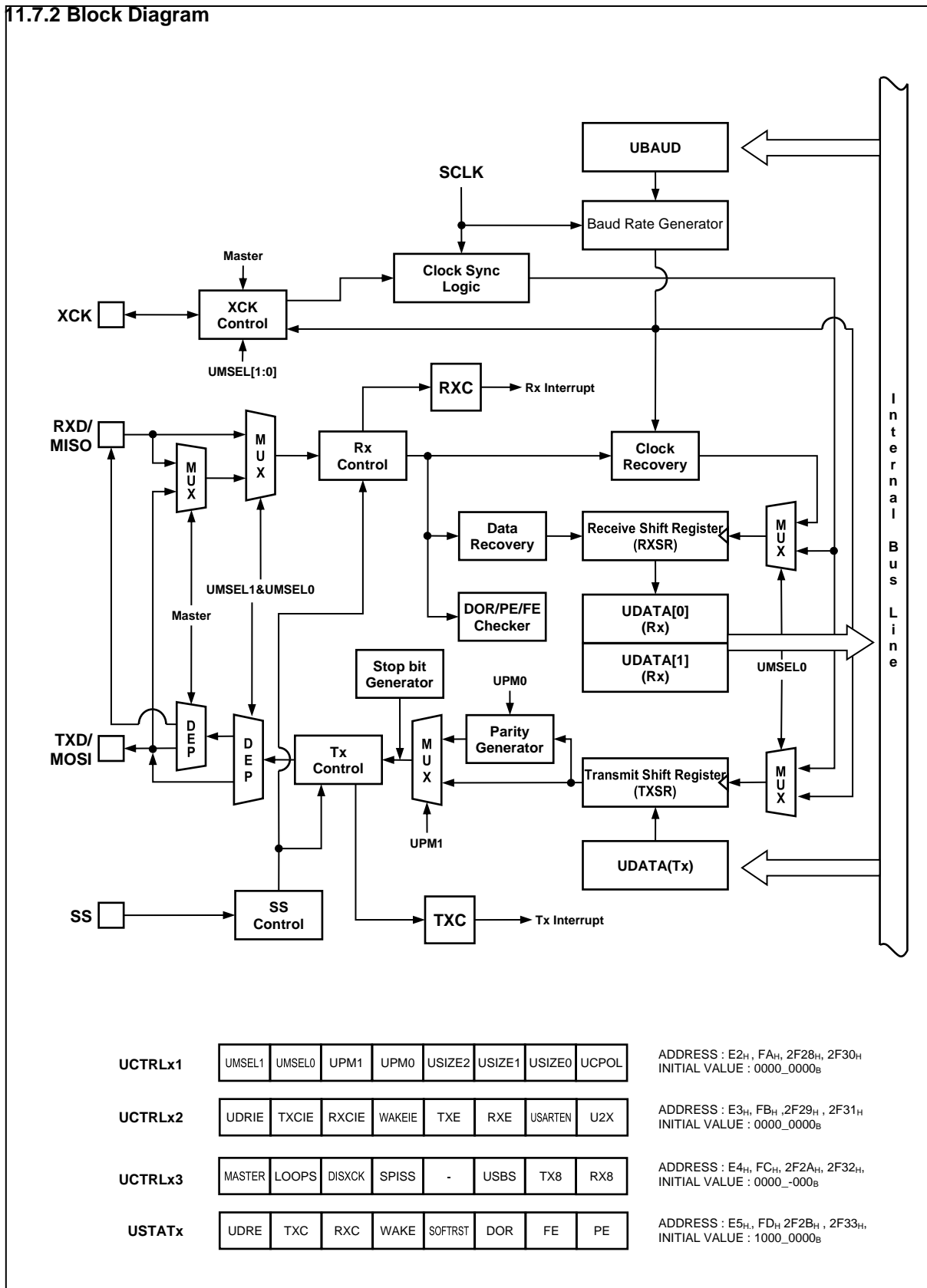

Figure 11.22 USART Block Diagram

11.7.3 Clock Generation

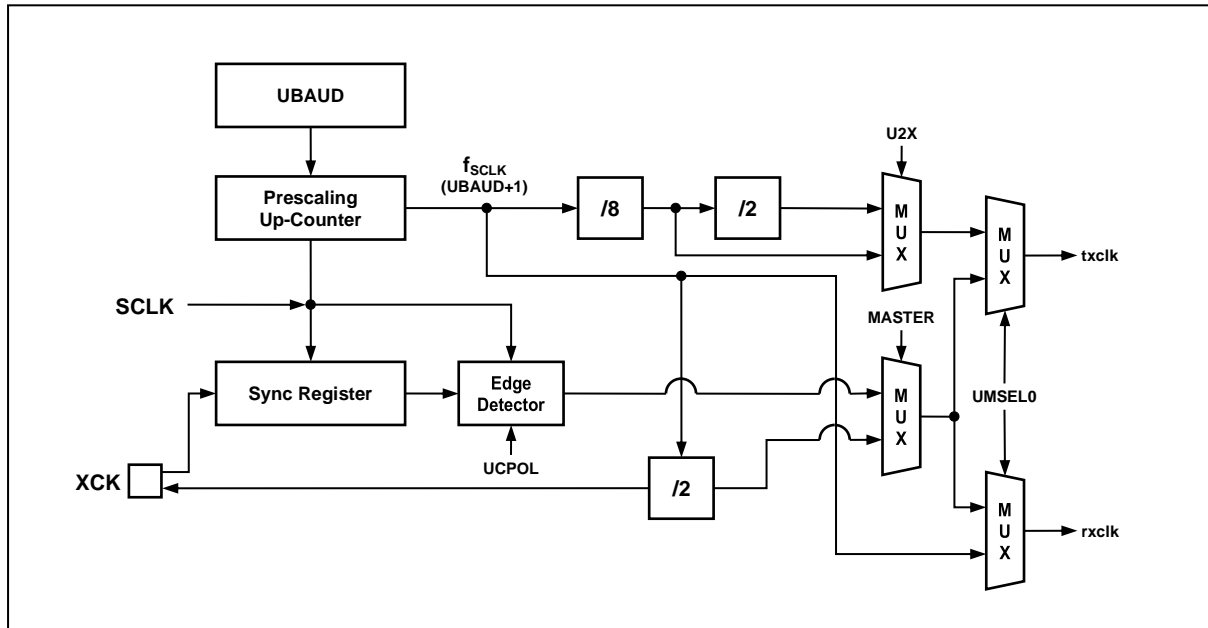

Figure 11.23 Clock Generation Block Diagram

The Clock generation logic generates the base clock for the Transmitter and Receiver. The USART supports four modes of clock operation and those are Normal Asynchronous, Double Speed Asynchronous, Master Synchronous and Slave Synchronous. The clock generation scheme for Master SPI and Slave SPI mode is the same as Master Synchronous and Slave Synchronous operation mode. The UMSELn bit in UCTRLx1 register selects between asynchronous and synchronous operation. Asynchronous Double Speed mode is controlled by the U2X bit in the UCTRLx2 register. The MASTER bit in UCTRLx2 register controls whether the clock source is internal (Master mode, output port) or external (Slave mode, input port). The XCK pin is only active when the USART operates in Synchronous or SPI mode.

Table below contains equations for calculating the baud rate (in bps).

Table 11-13 Equations for Calculating Baud Rate Register Setting

Operating Mode	Equation for Calculating Baud Rate
Asynchronous Normal Mode (U2X=0)	$\text{Baud Rate} = \frac{f_{\text{SCLK}}}{16(\text{UBAUD}_x + 1)}$
Asynchronous Double Speed Mode (U2X=1)	$\text{Baud Rate} = \frac{f_{\text{SCLK}}}{8(\text{UBAUD}_x + 1)}$
Synchronous or SPI Master Mode	$\text{Baud Rate} = \frac{f_{\text{SCLK}}}{2(\text{UBAUD}_x + 1)}$

### 11.7.4 External Clock (XCK)

External clocking is used by the synchronous or spi slave modes of operation.

External clock input from the XCK pin is sampled by a synchronization logic to remove meta-stability. The output from the synchronization logic must then pass through an edge detector before it can be used by the Transmitter and Receiver. This process introduces a two CPU clock period delay and therefore the maximum frequency of the external XCK pin is limited by the following equation.

$$f_{XCK} = \frac{f_{SCLK}}{4}$$

where  $f_{XCK}$  is the frequency of XCK and  $f_{SCLK}$  is the frequency of main system clock (SCLK).

### 11.7.5 Synchronous mode Operation

When synchronous or spi mode is used, the XCK pin will be used as either clock input (slave) or clock output (master). The dependency between the clock edges and data sampling or data change is the same. The basic principle is that data input on RXD (MISO in spi mode) pin is sampled at the opposite XCK clock edge of the edge in the data output on TXD (MOSI in spi mode) pin is changed.

The UC POL bit in UCTRLx1 register selects which XCK clock edge is used for data sampling and which is used for data change. As shown in the figure below, when UC POL is zero the data will be changed at rising XCK edge and sampled at falling XCK edge.

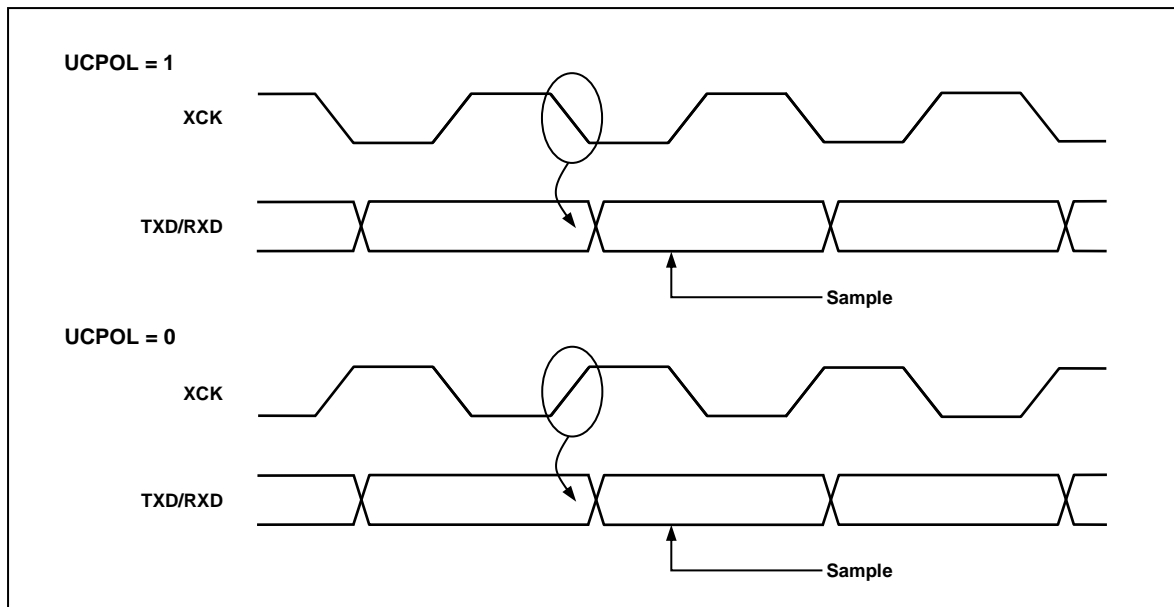

Figure 11.24 Synchronous Mode XCKn Timing

### 11.7.6 Data format

A serial frame is defined to be one character of data bits with synchronization bits (start and stop bits), and optionally a parity bit for error checking.

The USART supports all 30 combinations of the following as valid frame formats.

- 1 start bit
- 5, 6, 7, 8 or 9 data bits
- no, even or odd parity bit
- 1 or 2 stop bits

A frame starts with the start bit followed by the least significant data bit (LSB). Then the next data bits, up to a total of nine, are succeeding, ending with the most significant bit (MSB). If enabled the parity bit is inserted after the data bits, before the stop bits. A high to low transition on data pin is considered as start bit. When a complete frame is transmitted, it can be directly followed by a new frame, or the communication line can be set to an idle state. The idle means high state of data pin. The next figure shows the possible combinations of the frame formats. Bits inside brackets are optional.

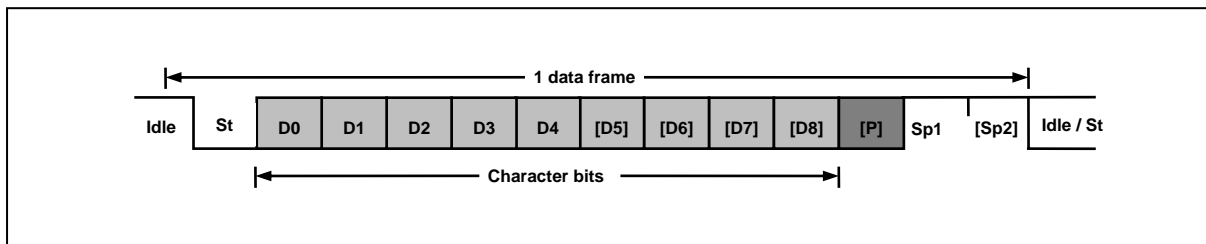

Figure 11.25 frame format

1 data frame consists of the following bits

- Idle No communication on communication line (TxD/RxD)
- St Start bit (Low)
- Dn Data bits (0~8)
- Parity bit ----- Even parity, Odd parity, No parity
- Stop bit(s) ----- 1 bit or 2 bits

The frame format used by the USART is set by the USIZE[2:0], UPM[1:0] and USBS bits in UCTRLx1 register. The Transmitter and Receiver use the same setting.

### 11.7.7 Priority bit

The parity bit is calculated by doing an exclusive-or of all the data bits. If odd parity is used, the result of the exclusive-or is inverted. The parity bit is located between the MSB and first stop bit of a serial frame.

$$P_{\text{even}} = D_{n-1} \wedge \dots \wedge D_3 \wedge D_2 \wedge D_1 \wedge D_0 \wedge 0$$

$$P_{\text{odd}} = D_{n-1} \wedge \dots \wedge D_3 \wedge D_2 \wedge D_1 \wedge D_0 \wedge 1$$

$P_{\text{even}}$  : Parity bit using even parity

$P_{\text{odd}}$  : Parity bit using odd parity

$D_n$  : Data bit n of the character

### 11.7.8 USART Transmitter

The USART Transmitter is enabled by setting the TXE bit in UCTRLx1 register. When the Transmitter is enabled, the normal port operation of the TXD pin is overridden by the serial output pin of USART. The baud-rate, operation mode and frame format must be setup once before doing any transmissions. If synchronous or spi operation is used, the clock on the XCK pin will be overridden and used as transmission clock. If USART operates in spi mode, SS pin is used as SS input pin in slave mode or can be configured as SS output pin in master mode. This can be done by setting SPISS bit in UCTRLx3 register.

#### 11.7.8.1 Sending Tx data

A data transmission is initiated by loading the transmit buffer (UDATAx register I/O location) with the data to be transmitted. The data written in transmit buffer is moved to the shift register when the shift register is ready to send a new frame. The shift register is loaded with the new data if it is in idle state or immediately after the last stop bit of the previous frame is transmitted. When the shift register is loaded with new data, it will transfer one complete frame at the settings of control registers. If the 9-bit characters are used in asynchronous or synchronous operation mode (USIZE[2:0]=7), the ninth bit must be written to the TX8 bit in UCTRLx3 register before loading transmit buffer (UDATA register).

#### 11.7.8.2 Transmitter flag and interrupt

The USART Transmitter has 2 flags which indicate its state. One is USART Data Register Empty (UDRE) and the other is Transmit Complete (TXC). Both flags can be interrupt sources.

UDRE flag indicates whether the transmit buffer is ready to be loaded with new data. This bit is set when the transmit buffer is empty and cleared when the transmit buffer contains data to be transmitted that has not yet been moved into the shift register. And also this flag can be cleared by writing '0' to this bit position. Writing '1' to this bit position is prevented.

When the Data Register Empty Interrupt Enable (UDRIE) bit in UCTRL2 register is set and the Global Interrupt is enabled, USART Data Register Empty Interrupt is generated while UDRE flag is set.

The Transmit Complete (TXC) flag bit is set when the entire frame in the transmit shift register has been shifted out and there are no more data in the transmit buffer. The TXC flag is automatically cleared when the Transmit Complete Interrupt service routine is executed, or it can be cleared by writing '0' to TXC bit in USTAT register.

When the Transmit Complete Interrupt Enable (TXCIE) bit in UCTRL2 register is set and the Global Interrupt is enabled, USART Transmit Complete Interrupt is generated while TXC flag is set.

### 11.7.8.3 Parity Generator

The Parity Generator calculates the parity bit for the sending serial frame data. When parity bit is enabled (UPM[1]=1), the transmitter control logic inserts the parity bit between the MSB and the first stop bit of the sending frame.

### 11.7.8.4 Disabling Transmitter

Disabling the Transmitter by clearing the TXE bit will not become effective until ongoing transmission is completed. When the Transmitter is disabled, the TXD pin is used as normal General Purpose I/O (GPIO) or primary function pin.

### 11.7.9 USART Receiver

The USART Receiver is enabled by setting the RXE bit in the UCTRLx1 register. When the Receiver is enabled, the normal pin operation of the RXD pin is overridden by the USART as the serial input pin of the Receiver. The baud-rate, mode of operation and frame format must be set before serial reception. If synchronous or spi operation is used, the clock on the XCK pin will be used as transfer clock. If USART operates in spi mode, SS pin is used as SS input pin in slave mode or can be configured as SS output pin in master mode. This can be done by setting SPISS bit in UCTRLx3 register.

#### 11.7.9.1 Receiving Rx data

When USART is in synchronous or asynchronous operation mode, the Receiver starts data reception when it detects a valid start bit (LOW) on RXD pin. Each bit after start bit is sampled at pre-defined baud-rate (asynchronous) or sampling edge of XCK (synchronous), and shifted into the receive shift register until the first stop bit of a frame is received. Even if there's 2<sup>nd</sup> stop bit in the frame, the 2<sup>nd</sup> stop bit is ignored by the Receiver. That is, receiving the first stop bit means that a complete serial frame is present in the receiver shift register and contents of the shift register are to be moved into the receive buffer. The receive buffer is read by reading the UDATAx register.

If 9-bit characters are used (USIZE[2:0] = 7) the ninth bit is stored in the RX8 bit position in the UCTRLx3 register. The 9<sup>th</sup> bit must be read from the RX8 bit before reading the low 8 bits from the UDATAx register. Likewise, the error flags FE, DOR, PE must be read before reading the data from UDATAx register. This is because the error flags are stored in the same FIFO position of the receive buffer.

#### 11.7.9.2 Receiver flag and interrupt

The USART Receiver has one flag that indicates the Receiver state.

The Receive Complete (RXC) flag indicates whether there are unread data present in the receive buffer. This flag is set when there are unread data in the receive buffer and cleared when the receive buffer is empty. If the Receiver is disabled (RXE=0), the receiver buffer is flushed and the RXC flag is cleared.

When the Receive Complete Interrupt Enable (RXCIE) bit in the UCTRLx2 register is set and Global Interrupt is enabled, the USART Receiver Complete Interrupt is generated while RXC flag is set.

The USART Receiver has three error flags which are Frame Error (FE), Data OverRun (DOR) and Parity Error (PE). These error flags can be read from the USTATx register. As data received are stored in the 2-level receive buffer, these error flags are also stored in the same position of receive buffer. So, before reading received data from UDATAx register, read the USTATx register first which contains error flags.

The Frame Error (FE) flag indicates the state of the first stop bit. The FE flag is zero when the stop bit was correctly detected as one, and the FE flag is one when the stop bit was incorrect, ie detected as zero. This flag can be used for detecting out-of-sync conditions between data frames.

The Data OverRun (DOR) flag indicates data loss due to a receive buffer full condition. A DOR occurs when the receive buffer is full, and another new data is present in the receive shift register which are to be stored into the receive buffer. After the DOR flag is set, all the incoming data are lost. To prevent data loss or clear this flag, read the receive buffer.

The Parity Error (PE) flag indicates that the frame in the receive buffer had a Parity Error when received. If Parity Check function is not enabled (UPM[1]=0), the PE bit is always read zero.

Note) The error flags related to receive operation are not used when USART is in spi mode.

### 11.7.9.3 Parity Checker

If Parity Bit is enabled (UPM[1]=1), the Parity Checker calculates the parity of the data bits in incoming frame and compares the result with the parity bit from the received serial frame.

### 11.7.9.4 Disabling Receiver

In contrast to Transmitter, disabling the Receiver by clearing RXE bit makes the Receiver inactive immediately. When the Receiver is disabled the Receiver flushes the receive buffer and the remaining data in the buffer is all reset. The RXD pin is not overridden the function of USART, so RXD pin becomes normal GPIO or primary function pin.

### 11.7.9.5 Asynchronous Data Reception

To receive asynchronous data frame, the USART includes a clock and data recovery unit. The Clock Recovery logic is used for synchronizing the internally generated baud-rate clock to the incoming asynchronous serial frame on the RXD pin.

The Data recovery logic samples and low pass filters the incoming bits, and this removes the noise of RXD pin.

The next figure illustrates the sampling process of the start bit of an incoming frame. The sampling rate is 16 times the baud-rate for normal mode, and 8 times the baud rate for Double Speed mode (U2X=1). The horizontal arrows show the synchronization variation due to the asynchronous sampling process. Note that larger time variation is shown when using the Double Speed mode.

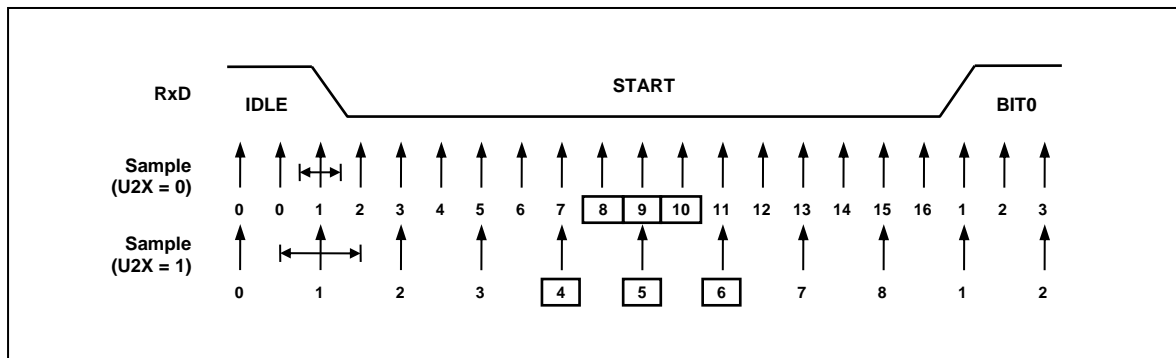

Figure 11.26 Start Bit Sampling

When the Receiver is enabled (RXE=1), the clock recovery logic tries to find a high to low transition on the RXD line, the start bit condition. After detecting high to low transition on RXD line, the clock recovery logic uses samples 8,9, and 10 for Normal mode, and samples 4, 5, and 6 for Double Speed mode to decide if a valid start bit is received. If more than 2 samples have logical low level, it is considered that a valid start bit is detected and the internally generated clock is synchronized to the incoming data frame. And the data recovery can begin. The synchronization process is repeated for each start bit.

As described above, when the Receiver clock is synchronized to the start bit, the data recovery can begin. Data recovery process is almost similar to the clock recovery process. The data recovery logic samples 16 times for each incoming bits for Normal mode and 8 times for Double Speed mode. And uses sample 8, 9, and 10 to decide data value for Normal mode, samples 4, 5, and 6 for Double Speed mode. If more than 2 samples have low levels, the received bit is considered to a logic 0 and more than 2 samples have high levels, the received bit is considered to a logic 1. The data recovery process is then repeated until a complete frame is received including the first stop bit. The decided bit value is stored in the receive shift register in order. Note that the Receiver only uses the first stop bit of a frame. Internally, after receiving the first stop bit, the Receiver is in idle state and waiting to find start bit.

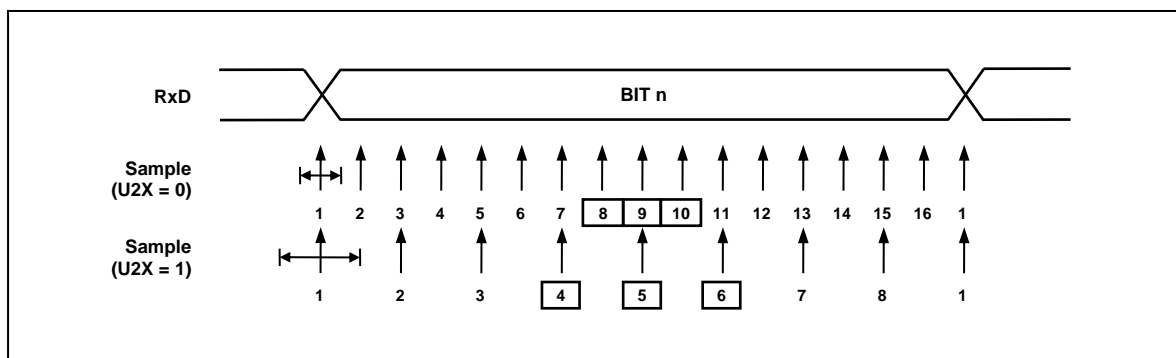

Figure 11.27 Sampling of Data and Parity Bit

The process for detecting stop bit is like clock and data recovery process. That is, if 2 or more samples of 3 center values have high level, correct stop bit is detected, else a Frame Error flag is set. After deciding first stop bit whether a valid stop bit is received or not, the Receiver goes idle state and monitors the RXD line to check a valid high to low transition is detected (start bit detection).



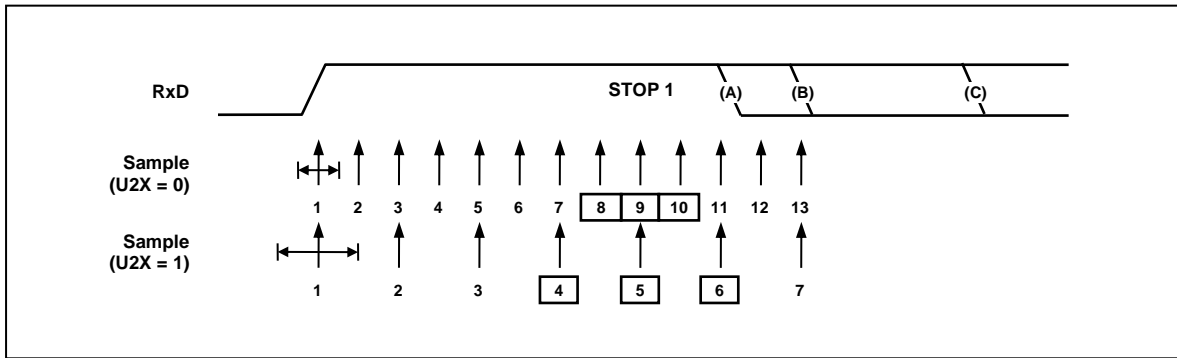

Figure 11.28 Stop Bit Sampling and Next Start Bit Sampling

### 11.7.10 SPI Mode

The USART can be set to operate in industrial standard SPI compliant mode. The SPI mode has the following features.

- Full duplex, three-wire synchronous data transfer
- Master or Slave operation
- Supports all four SPI modes of operation (mode0, 1, 2, and 3)
- Selectable LSB first or MSB first data transfer
- Double buffered transmit and receive
- Programmable transmit bit rate

When SPI mode is enabled (UMSEL[1:0]=3), the Slave Select (SS) pin becomes active low input in slave mode operation, or can be output in master mode operation if SPISS bit is set.

Note that during SPI mode of operation, the pin RXD is renamed as MISO and TXD is renamed as MOSI for compatibility to other SPI devices.

#### 11.7.10.1 SPI Clock formats and timing

To accommodate a wide variety of synchronous serial peripherals from different manufacturers, the USART has a clock polarity bit (UCPOL) and a clock phase control bit (UCPHA) to select one of four clock formats for data transfers. UC POL selectively insert an inverter in series with the clock. UCPHA chooses between two different clock phase relationships between the clock and data. Note that UCPHA and UC POL bits in UCTRLx1 register have different meanings according to the UMSEL[1:0] bits which decides the operating mode of USART.

Table below shows four combinations of UC POL and UCPHA for SPI mode 0, 1, 2, and 3.

Table 11-14 CPOL Funtionality

SPI Mode	UCPOL	UCPHA	Leading Edge	Trailing Edge
0	0	0	Sample (Rising)	Setup (Falling)
1	0	1	Setup (Rising)	Sample (Falling)
2	1	0	Sample (Falling)	Setup (Rising)
3	1	1	Setup (Falling)	Sample (Rising)

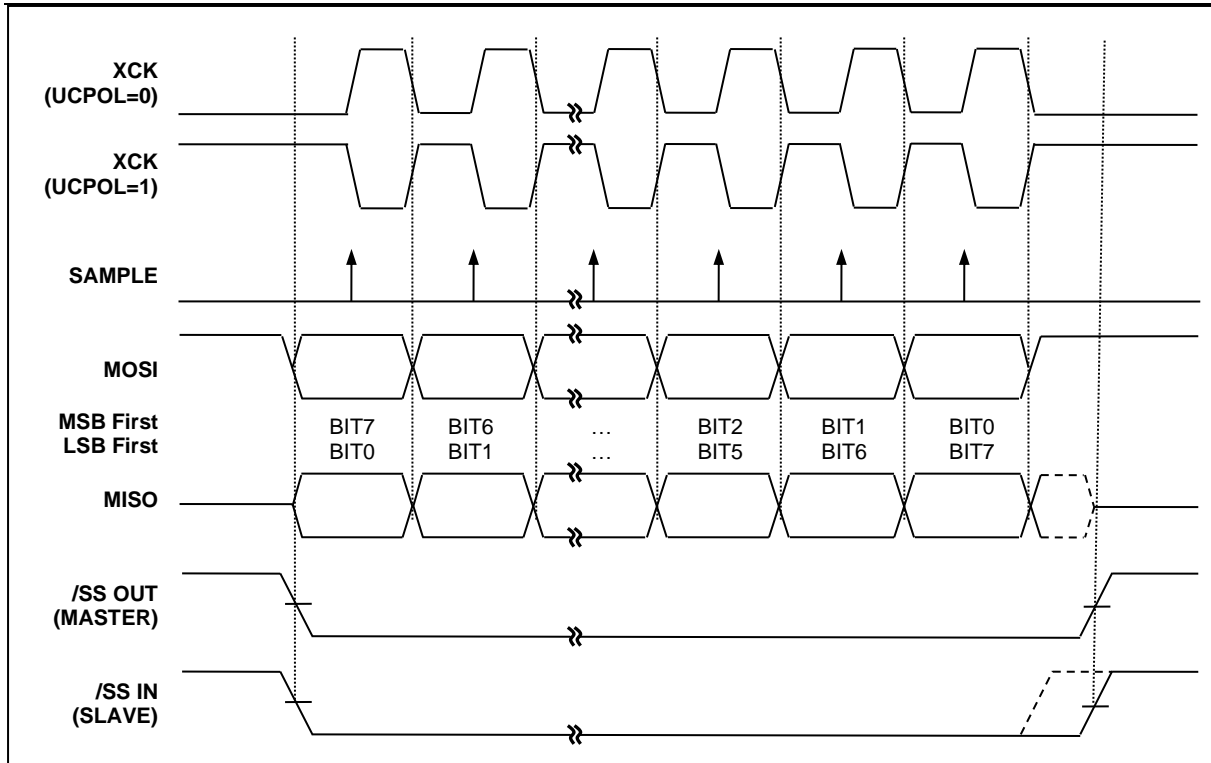

**Figure 11.29 SPI Clock Formats when UCPHA=0**

When UCPHA=0, the slave begins to drive its MISO output with the first data bit value when SS goes to active low. The first XCK edge causes both the master and the slave to sample the data bit value on their MISO and MOSI inputs, respectively. At the second XCK edge, the USART shifts the second data bit value out to the MOSI and MISO outputs of the master and slave, respectively. Unlike the case of UCPHA=1, when UCPHA=0, the slave's SS input must go to its inactive high level between transfers. This is because the slave can prepare the first data bit when it detects falling edge of SS input.

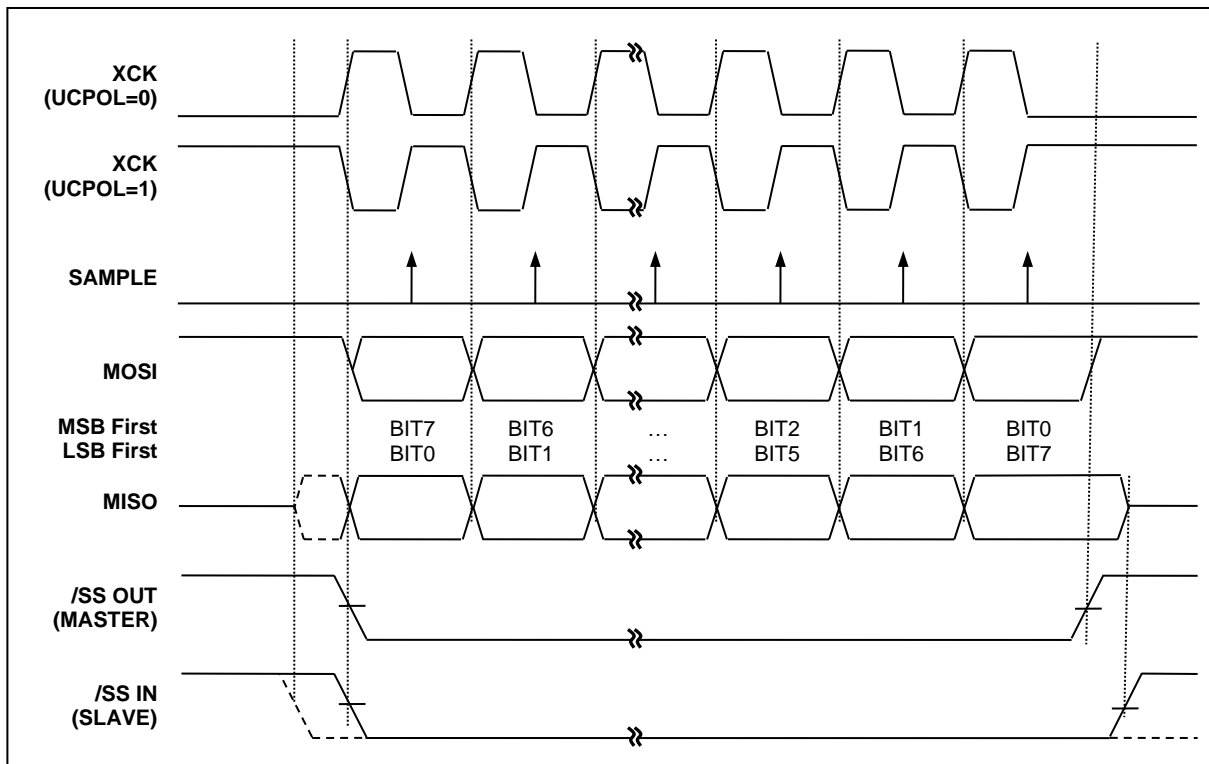

Figure 11.30 SPI Clock Formats when UCPHA=1

When UCPHA=1, the slave begins to drive its MISO output when SS goes active low, but the data is not defined until the first XCK edge. The first XCK edge shifts the first bit of data from the shifter onto the MOSI output of the master and the MISO output of the slave. The next XCK edge causes both the master and slave to sample the data bit value on their MISO and MOSI inputs, respectively. At the third XCK edge, the USART shifts the second data bit value out to the MOSI and MISO output of the master and slave respectively. When UCPHA=1, the slave's SS input is not required to go to its inactive high level between transfers.

Because the SPI logic reuses the USART resources, SPI mode of operation is similar to that of synchronous or asynchronous operation. An SPI transfer is initiated by checking for the USART Data Register Empty flag (UDRE=1) and then writing a byte of data to the UDATA Register. In master mode of operation, even if transmission is not enabled (TXE=0), writing data to the UDATA register is necessary because the clock XCK is generated from transmitter block.

### 11.7.11 Register Map

Table 11-15 Register Map

Name	Address	Dir	Default	Description
UCTRL01	E2H	R/W	00H	USART Control 1 Register 0
UCTRL02	E3H	R/W	00H	USART Control 2 Register 0
UCTRL03	E4H	R/W	00H	USART Control 3 Register 0
USTAT0	E5H	R	80H	USART Status Register 0
UBAUD0	E6H	R/W	FFH	USART Baud Rate Generation Register 0
UDATA0	E7H	R/W	00H	USART Data Register 0

UCTRL11	FAH	R/W	00H	USART Control 1 Register 1
UCTRL12	FBH	R/W	00H	USART Control 2 Register 1
UCTRL13	FCH	R/W	00H	USART Control 3 Register 1
USTAT1	FDH	R	80H	USART Status Register 1
UBAUD1	FEH	R/W	FFH	USART Baud Rate Generation Register 1
UDATA1	FFH	R/W	FFH	USART Data Register 2
UCTRL21	2F28H	R/W	00H	USART Control 1 Register 2
UCTRL22	2F29H	R/W	00H	USART Control 2 Register 2
UCTRL23	2F2AH	R/W	00H	USART Control 3 Register 2
USTAT2	2F2BH	R	80H	USART Status Register 2
UBAUD2	2F2CH	R/W	FFH	USART Baud Rate Generation Register 2
UDATA2	2F2DH	R/W	FFH	USART Data Register 2
UCTRL31	2F30H	R/W	00H	USART Control 1 Register 3
UCTRL32	2F31H	R/W	00H	USART Control 2 Register 3
UCTRL33	2F32H	R/W	00H	USART Control 3 Register 3
USTAT3	2F33H	R	80H	USART Status Register 3
UBAUD3	2F34H	R/W	FFH	USART Baud Rate Generation Register 3
UDATA3	2F35H	R/W	FFH	USART Data Register 3

### 11.7.12 USART Register description

USART module consists of USART Control 1 Register (UCTRLx1), USART Control 2 Register (UCTRLx2), USART Control 3 Register (UCTRLx3), USART Status Register (USTATx), USART Data Register (UDATAx), and USART Baud Rate Generation Register (UBAUDx).

### 11.7.13 Register description for USART

#### UCTRLx1 (USART Control 1 Register) : E2H, FAH, 2F28H, 2F30H

7	6	5	4	3	2	1	0
UMSEL1	UMSEL0	UPM1	UPM0	USIZE2	USIZE1 UDORD	USIZE0 UCPHA	UCPOL
R/W	R/W	R/W	R/W	R/W	R/W	R/W	R/W

Initial value : 00H

<b>UMSEL[1:0]</b>	Selects operation mode of USART.		
UMSEL1	UMSEL0	Operation Mode	
0	0	Asynchronous Mode (Uart)	
0	1	Synchronous Mode	
1	0	Reserved	
1	1	SPI Mode	
<b>UPM[1:0]</b>	Selects Parity Generation and Check methods		
UPM1	UPM0	Parity	
0	0	No Parity	
0	1	Reserved	
1	0	Even Parity	

	1	1	Odd Parity	
<b>USIZE[2:0]</b>	When in asynchronous or synchronous mode of operation, selects the length of data bits in frame.			
	USIZE2	USIZE1	USIZE0	Data Length
	0	0	0	5 bit
	0	0	1	6 bit
	0	1	0	7 bit
	0	1	1	8 bit
	1	0	0	Reserved
	1	0	1	Reserved
	1	1	0	Reserved
	1	1	1	9 bit
<b>UDORD</b>	This bit is in the same bit position with USIZE1. In SPI mode, when set to one the MSB of the data byte is transmitted first. When set to zero the LSB of the data byte is transmitted first.			
	0	LSB First		
	1	MSB First		
<b>UCPOL</b>	Selects polarity of XCK in synchronous or spi mode			
	0	TXD change @Rising Edge, RXD change @Falling Edge		
	1	TXD change @ Falling Edge, RXD change @ Rising Edge		
<b>UCPHA</b>	This bit is in the same bit position with USIZE0. In SPI mode, along with UCPOL bit, selects one of two clock formats for different kinds of synchronous serial peripherals. Leading edge means first XCK edge and trailing edge means 2 <sup>nd</sup> or last clock edge of XCK in one XCK pulse. And Sample means detecting of incoming receive bit, Setup means preparing transmit data.			
	UCPOL	UCPHA	Leading Edge	Trailing Edge
	0	0	Sample (Rising)	Setup (Falling)
	0	1	Setup (Rising)	Sample (Falling)
	1	0	Sample (Falling)	Setup (Rising)
	1	1	Setup (Falling)	Sample (Rising)

**UCTRLx2 (USART Control 2 Register) : E3H, FBH, 2F29H, 2F31H**

7	6	5	4	3	2	1	0
UDRIE	TXCIE	RXCIE	WAKEIE	TXE	RXE	USARTEN	U2X
RW	RW	RW	RW	RW	RW	RW	RW

Initial value : 00H

<b>UDRIE</b>	Interrupt enable bit for USART Data Register Empty.
0	Interrupt from UDRE is inhibited (use polling)
1	When UDRE is set, request an interrupt
<b>TXCIE</b>	Interrupt enable bit for Transmit Complete.
0	Interrupt from TXC is inhibited (use polling)
1	When TXC is set, request an interrupt
<b>RXCIE</b>	Interrupt enable bit for Receive Complete
0	Interrupt from RXC is inhibited (use polling)
1	When RXC is set, request an interrupt
<b>WAKEIE</b>	Interrupt enable bit for Asynchronous Wake in STOP mode. When device is in stop mode, if RXD goes to LOW level an interrupt can be requested to wake-up system.

	0	Interrupt from Wake is inhibited
	1	When WAKE is set, request an interrupt
<b>TXE</b>		Enables the transmitter unit.
	0	Transmitter is disabled
	1	Transmitter is enabled
<b>RXE</b>		Enables the receiver unit.
	0	Receiver is disabled
	1	Receiver is enabled
<b>USARTEN</b>		Activate USART module by supplying clock.
	0	USART is disabled (clock is halted)
	1	USART is enabled
<b>U2X</b>		This bit only has effect for the asynchronous operation and selects receiver sampling rate.
	0	Normal asynchronous operation
	1	Double Speed asynchronous operation

**UCTRLx3 (USART Control 3 Register) : E4H, FCH, 2F2AH, 2F32H**

7	6	5	4	3	2	1	0
MASTER	LOOPS	DISXCK	SPISS	-	USBS	TX8	RX8
R/W	R/W	R/W	R/W	-	R/W	R/W	R/W

Initial value : 00H

<b>MASTER</b>	Selects master or slave in SPI or Synchronous mode operation and controls the direction of XCK pin.
	0 Slave mode operation and XCK is input pin.
	1 Master mode operation and XCK is output pin
<b>LOOPS</b>	Controls the Loop Back mode of USART, for test mode
	0 Normal operation
	1 Loop Back mode
<b>DISXCK</b>	In Synchronous mode of operation, selects the waveform of XCK output.
	0 XCK is free-running while USART is enabled in synchronous master mode.
	1 XCK is active while any frame is on transferring.
<b>SPISS</b>	Controls the functionality of SS pin in master SPI mode.
	0 SS pin is normal GPIO or other primary function
	1 SS output to other slave device
<b>USBS</b>	Selects the length of stop bit in Asynchronous or Synchronous mode of operation.
	0 1 Stop Bit
	1 2 Stop Bit
<b>TX8</b>	The ninth bit of data frame in Asynchronous or Synchronous mode of operation. Write this bit first before loading the UDATA register.
	0 MSB (9 <sup>th</sup> bit) to be transmitted is '0'
	1 MSB (9 <sup>th</sup> bit) to be transmitted is '1'
<b>RX8</b>	The ninth bit of data frame in Asynchronous or Synchronous mode of operation. Read this bit first before reading the receive buffer.
	0 MSB (9 <sup>th</sup> bit) received is '0'
	1 MSB (9 <sup>th</sup> bit) received is '1'

**USTATx (USART Status Register) : E5H, FDH, 2F2BH, 2F33H**

7	6	5	4	3	2	1	0
UDRE	TXC	RXC	WAKE	SOFTRST	DOR	FE	PE
RW	RW	RW	RW	RW	R	R	R

Initial value : 80H

<b>UDRE</b>	The UDRE flag indicates if the transmit buffer (UDATA) is ready to be loaded with new data. If UDRE is '1', it means the transmit buffer is empty and can hold one or two new data. This flag can generate an UDRE interrupt. Writing '0' to this bit position will clear UDRE flag.
0	Transmit buffer is not empty.
1	Transmit buffer is empty.
<b>TXC</b>	This flag is set when the entire frame in the transmit shift register has been shifted out and there is no new data currently present in the transmit buffer. This flag is automatically cleared when the interrupt service routine of a TXC interrupt is executed. It is also cleared by writing '0' to this bit position. This flag can generate a TXC interrupt.
0	Transmission is ongoing.
1	Transmit buffer is empty and the data in transmit shift register are shifted out completely.
<b>RXC</b>	This flag is set when there are unread data in the receive buffer and cleared when all the data in the receive buffer are read. The RXC flag can be used to generate a RXC interrupt.
0	There is no data unread in the receive buffer
1	There are more than 1 data in the receive buffer
<b>WAKE</b>	This flag is set when the RX pin is detected low while the CPU is in stop mode. This flag can be used to generate a WAKE interrupt. This bit is set only when in asynchronous mode of operation. <sup>NOTE</sup>
0	No WAKE interrupt is generated.
1	WAKE interrupt is generated.
<b>SOFTRST</b>	This is an internal reset and only has effect on USART. Writing '1' to this bit initializes the internal logic of USART and is auto cleared.
0	No operation
1	Reset USART
<b>DOR</b>	This bit is set if a Data OverRun occurs. While this bit is set, the incoming data frame is ignored. This flag is valid until the receive buffer is read.
0	No Data OverRun
1	Data OverRun detected
<b>FE</b>	This bit is set if the first stop bit of next character in the receive buffer is detected as '0'. This bit is valid until the receive buffer is read.
0	No Frame Error
1	Frame Error detected
<b>PE</b>	This bit is set if the next character in the receive buffer has a Parity Error when received while Parity Checking is enabled. This bit is valid until the receive buffer is read.
0	No Parity Error
1	Parity Error detected

<sup>NOTE</sup> When the WAKE function of USART is used as a release source from STOP mode, it is required to clear this bit in the RX interrupt service routine. Else the device will not wake-up from STOP mode again by the change of RX pin.

**UBAUDx(USART Baud-Rate Generation Register) : E6H, FEH, 2F2CH, 2F34H**

7	6	5	4	3	2	1	0
UBAUD7	UBAUD6	UBAUD5	UBAUD4	UBAUD3	UBAUD2	UBAUD1	UBAUD0
RW	RW	RW	RW	RW	RW	RW	RW

Initial value : FFH

**UBAUD [7:0]** The value in this register is used to generate internal baud rate in asynchronous mode or to generate XCK clock in synchronous or spi mode. To prevent malfunction, do not write '0' in asynchronous mode, and do not write '0' or '1' in synchronous or spi mode.

**UDATAx (USART Data Register) : E7H, FFH, 2F2DH, 2F34H**

7	6	5	4	3	2	1	0
UDATA7	UDATA6	UDATA5	UDATA4	UDATA3	UDATA2	UDATA1	UDATA0
RW	RW	RW	RW	RW	RW	RW	RW

Initial value : FFH

**UDATA [7:0]** The USART Transmit Buffer and Receive Buffer share the same I/O address with this DATA register. The Transmit Data Buffer is the destination for data written to the UDATA register. Reading the UDATA register returns the contents of the Receive Buffer. Write this register only when the UDRE flag is set. In spi or synchronous master mode, write this register even if TX is not enabled to generate clock, XCK.



**11.7.14 Baud Rate setting (example)**

**Table 11-16 Examples of UBAUD Settings for Commonly Used Oscillator Frequencies**

Baud Rate	fOSC=1.00MHz				fOSC=1.8432MHz				fOSC=2.00MHz			
	U2X=0		U2X=1		U2X=0		U2X=1		U2X=0		U2X=1	
	UBAUD	ERROR	UBAUD	ERROR	UBAUD	ERROR	UBAUD	ERROR	UBAUD	ERROR	UBAUD	ERROR
2400	25	0.2%	51	0.2%	47	0.0%	95	0.0%	51	0.2%	103	0.2%
4800	12	0.2%	25	0.2%	23	0.0%	47	0.0%	25	0.2%	51	0.2%
9600	6	-7.0%	12	0.2%	11	0.0%	23	0.0%	12	0.2%	25	0.2%
14.4K	3	8.5%	8	-3.5%	7	0.0%	15	0.0%	8	-3.5%	16	2.1%
19.2K	2	8.5%	6	-7.0%	5	0.0%	11	0.0%	6	-7.0%	12	0.2%
28.8K	1	8.5%	3	8.5%	3	0.0%	7	0.0%	3	8.5%	8	-3.5%
38.4K	1	-18.6%	2	8.5%	2	0.0%	5	0.0%	2	8.5%	6	-7.0%
57.6K	-	-	1	8.5%	1	-25.0%	3	0.0%	1	8.5%	3	8.5%
76.8K	-	-	1	-18.6%	1	0.0%	2	0.0%	1	-18.6%	2	8.5%
115.2K	-	-	-	-	-	-	1	0.0%	-	-	1	8.5%
230.4K	-	-	-	-	-	-	-	-	-	-	-	-
Baud Rate	fOSC=3.6864MHz				fOSC=4.00MHz				fOSC=7.3728MHz			
	U2X=0		U2X=1		U2X=0		U2X=1		U2X=0		U2X=1	
	UBAUD	ERROR	UBAUD	ERROR	UBAUD	ERROR	UBAUD	ERROR	UBAUD	ERROR	UBAUD	ERROR
2400	95	0.0%	191	0.0%	103	0.2%	207	0.2%	191	0.0%	-	-
4800	47	0.0%	95	0.0%	51	0.2%	103	0.2%	95	0.0%	191	0.0%
9600	23	0.0%	47	0.0%	25	0.2%	51	0.2%	47	0.0%	95	0.0%
14.4K	15	0.0%	31	0.0%	16	2.1%	34	-0.8%	31	0.0%	63	0.0%
19.2K	11	0.0%	23	0.0%	12	0.2%	25	0.2%	23	0.0%	47	0.0%
28.8K	7	0.0%	15	0.0%	8	-3.5%	16	2.1%	15	0.0%	31	0.0%
38.4K	5	0.0%	11	0.0%	6	-7.0%	12	0.2%	11	0.0%	23	0.0%
57.6K	3	0.0%	7	0.0%	3	8.5%	8	-3.5%	7	0.0%	15	0.0%
76.8K	2	0.0%	5	0.0%	2	8.5%	6	-7.0%	5	0.0%	11	0.0%
115.2K	1	0.0%	3	0.0%	1	8.5%	3	8.5%	3	0.0%	7	0.0%
230.4K	-	-	1	0.0%	-	-	1	8.5%	1	0.0%	3	0.0%
250K	-	-	1	-7.8%	-	-	1	0.0%	1	-7.8%	3	-7.8%
0.5M	-	-	-	-	-	-	-	-	-	-	1	-7.8%
Baud Rate	fOSC=8.00MHz				fOSC=11.0592MHz				fOSC=14.7456MHz			
	U2X=0		U2X=1		U2X=0		U2X=1		U2X=0		U2X=1	
	UBAUD	ERROR	UBAUD	ERROR	UBAUD	ERROR	UBAUD	ERROR	UBAUD	ERROR	UBAUD	ERROR
2400	207	0.2%	-	-	-	-	-	-	-	-	-	-
4800	103	0.2%	207	0.2%	143	0.0%	-	-	191	0.0%	-	-
9600	51	0.2%	103	0.2%	71	0.0%	143	0.0%	95	0.0%	191	0.0%
14.4K	34	-0.8%	68	0.6%	47	0.0%	95	0.0%	63	0.0%	127	0.0%
19.2K	25	0.2%	51	0.2%	35	0.0%	71	0.0%	47	0.0%	95	0.0%
28.8K	16	2.1%	34	-0.8%	23	0.0%	47	0.0%	31	0.0%	63	0.0%
38.4K	12	0.2%	25	0.2%	17	0.0%	35	0.0%	23	0.0%	47	0.0%
57.6K	8	-3.5%	16	2.1%	11	0.0%	23	0.0%	15	0.0%	31	0.0%
76.8K	6	-7.0%	12	0.2%	8	0.0%	17	0.0%	11	0.0%	23	0.0%
115.2K	3	8.5%	8	-3.5%	5	0.0%	11	0.0%	7	0.0%	15	0.0%
230.4K	1	8.5%	3	8.5%	2	0.0%	5	0.0%	3	0.0%	7	0.0%
250K	1	0.0%	3	0.0%	2	-7.8%	5	-7.8%	3	-7.8%	6	5.3%
0.5M	-	-	1	0.0%	-	-	2	-7.8%	1	-7.8%	3	-7.8%
1M	-	-	-	-	-	-	-	-	-	-	1	-7.8%

## 11.8 SPI

### 11.8.1 Overview

There is Serial Peripheral Interface (SPI) one channel in MC95FG0128A. The SPI allows synchronous serial data transfer between the external serial devices. It can do Full-duplex communication by 4-wire (MOSI, MISO, SCK, SS), support Master/Slave mode, can select serial clock (SCK) polarity, phase and whether LSB first data transfer or MSB first data transfer.

### 11.8.2 Block Diagram

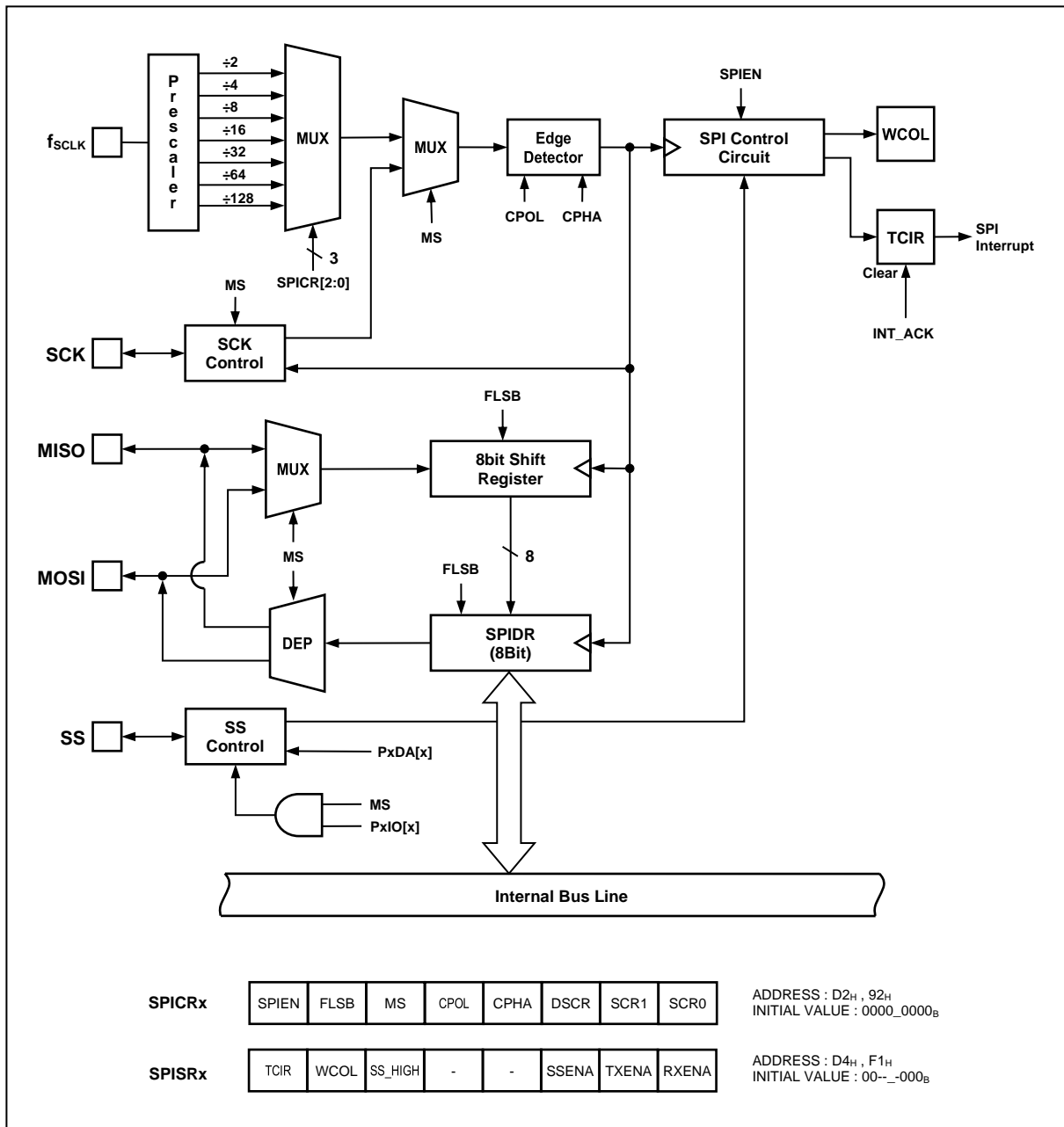

Figure 11.31 SPI Block Diagram

### 11.8.3 Data Transmit / Receive Operation

User can use SPI for serial data communication by following step

1. Select SPI operation mode(master/slave, polarity, phase) by control register SPICR.
2. When the SPI is configured as a Master, it selects a Slave by SS signal (active low).  
When the SPI is configured as a Slave, it is selected by SS signal incoming from Master
3. When the user writes a byte to the data register SPIDRx, SPI will start an operation.
4. In this time, if the SPI is configured as a Master, serial clock will come out of SCK pin. And Master shifts the eight bits into the Slave (transmit), Slave shifts the eight bits into the Master at the same time (receive). If the SPI is configured as a Slave, serial clock will come into SCK pin. And Slave shifts the eight bits into the Master (transmit), Master shifts the eight bits into the Slave at the same time (receive).
5. When transmit/receive is done, TCIR (Transmit Complete or Interrupt Request) bit will be set. If the SPI interrupt is enabled, an interrupt is requested. And TCIR bit is cleared by hardware when executing the corresponding interrupt. If SPI interrupt is disable, TCIR bit is cleared when user read the status register SPISRx, and then access (read/write) the data register SPIDR.

Note) If you want to use both transmit and receive, set the TXENA, RXENA bit of SPISR, and if user want to use only either transmit or receive, clear the TXENA or RXENA. In this case, user can use disabled pin by GPIO freely.

### 11.8.4 SS pin function

1. When the SPI is configured as a Slave, the SS pin is always input. If LOW signal come into SS pin, the SPI logic is active. And if 'HIGH' signal come into SS pin, the SPI logic is stop. In this time, SPI logic will be reset, and invalidated any received data.
2. When the SPI is configured as a Master, the user can select the direction of the SS pin by port direction register (PxIO[x]). If the SS pin is configured as an output, user can use general GPIO output mode. If the SS pin is configured as an input, 'HIGH' signal must come into SS pin to guarantee Master operation. If 'LOW' signal come into SS pin, the SPI logic interprets this as another master selecting the SPI as a slave and starting to send data to it. To avoid bus contention, MS bit of SPICR will be cleared and the SPI becomes a Slave and then, TCIR bit of SPISR will be set, and if the SPI interrupt is enabled, an interrupt is requested.

Note)

- When the SS pin is configured as an output at Master mode, SS pin's output value is defined by user's software (PxDA[x]). Before SPICRx setting, the direction of SS pin must be defined
- If you don't need to use SS pin, clear the SENA bit of SPISR. So, you can use disabled pin by GPIO freely. In this case, SS signal is driven by 'HIGH' or 'LOW' internally. In other words, master is 'HIGH', slave is 'LOW'
- When SS pin is configured as input(master or slave), if 'HIGH' signal come into SS pin, this flag bit will be set at the SS rising time. And you can clear it by writing '0'.

### 11.8.5 Timing Waveform

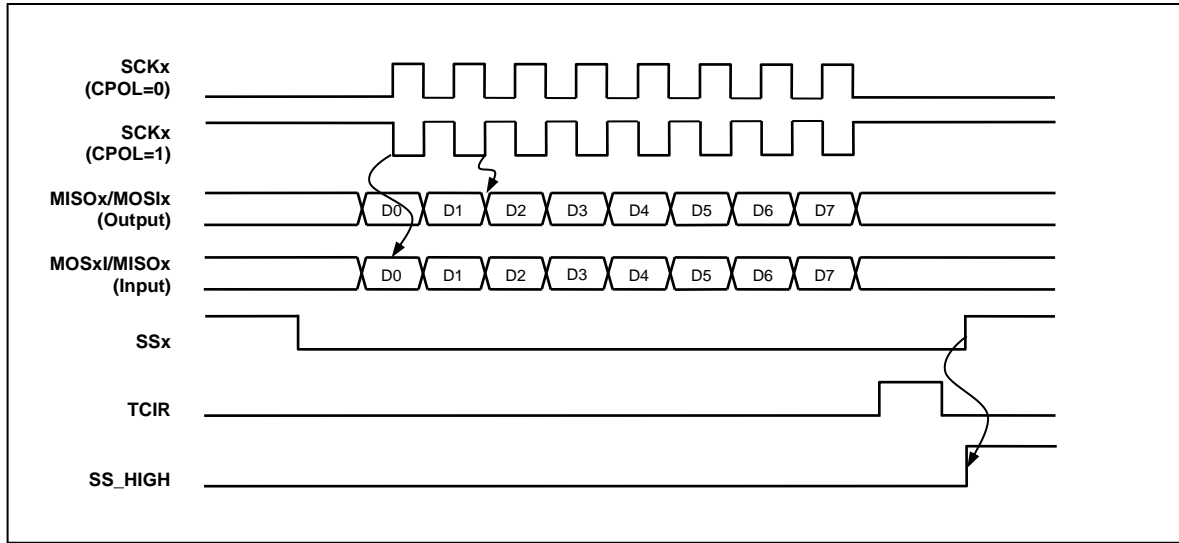

Figure 11.32 SPI Transmit/Receive Timing Diagram at CPHA = 0

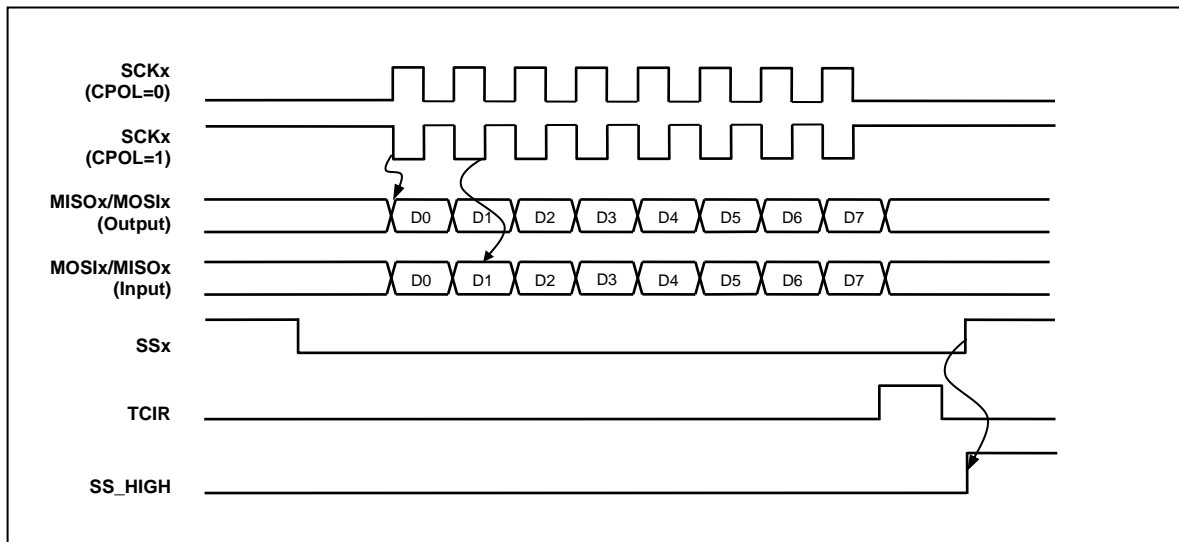

Figure 11.33 SPI Transmit/Receive Timing Diagram at CPHA = 1

### 11.8.6 Register Map

Table 11-17 Register Map

Name	Address	Dir	Default	Description
SPICR0	D2H	R/W	0H	SPI Control Register 0
SPIDR0	D3H	R/W	0H	SPI Data Register 0
SPISR0	D4H	-	0H	SPI Status Register 0
SPICR1	92H	R/W	0H	SPI Control Register 1
SPIDR1	93H	R/W	0H	SPI Data Register 1
SPISR1	F1H	-	0H	SPI Status Register 1

### 11.8.7 SPI Register description

The SPI Register consists of SPI Control Register (SPICRx), SPI Status Register (SPISRx) and SPI Data Register (SPIDRx)

### 11.8.8 Register description for SPI

#### SPICRx (SPI Control Register) : D2H, 92H

7	6	5	4	3	2	1	0
SPIEN	FLSB	MS	CPOL	CPHA	DSCR	SCR1	SCR0
R/W	R/W	R/W	R/W	R/W	R/W	R/W	R/W

Initial value : 00H

<b>SPIEN</b>	This bit controls the SPI operation		
0	SPI Disable		
1	SPI Enable		
<b>FLSB</b>	This bit selects the data transmission sequence		
0	MSB First		
1	LSB First		
<b>MS</b>	This bit selects whether Master or Slave mode		
0	Slave mode		
1	Master mode		
<b>CPOL</b>	These two bits control the serial clock (SCK) mode		
<b>CPHA</b>	Clock Polarity (CPOL) bit determine SCK's value at idle mode		
	Clock Phase (CPHA) bit determine if data is sampled on the leading or trailing edge of SCK. Refer to Figure 11.32, Figure 11.33.		
	CPOL	CPHA	Leading Edge      Trailing Edge
	0	0	Sample (Rising)      Setup (Falling)
	0	1	Setup (Rising)      Sample (Falling)
	1	0	Sample (Falling)      Setup (Rising)
	1	1	Setup (Falling)      Sample (Rising)
<b>DSCR</b>	These three bits select the SCK rate of the device configured as a Master.		
<b>SCR[2:0]</b>	When DSCR bit is written one, SCK will be doubled in Master mode.		
	fx– Main system clock oscillation frequency.		
	DSCR	SCR1	SCR0      SCK frequency
	0	0	0      fx/4
	0	0	1      fx/16
	0	1	0      fx/64
	0	1	1      fx/128
	1	0	0      fx/2
	1	0	1      fx/8
	1	1	0      fx/32
	1	1	1      fx/64

**SPIDRx (SPI Data Register) : D3H, 93H**

7	6	5	4	3	2	1	0
SPIDR7	SPIDR6	SPIDR5	SPIDR4	SPIDR3	SPIDR2	SPIDR1	SPIDR0
RW	RW	RW	RW	RW	RW	RW	RW

Initial value : 00H

**SPIDR [7:0]** SPI data register.  
Although you only use reception, user must write any data in here to start the SPI operation.

**SPISRx (SPI Status Register) : D4H, F1H**

7	6	5	4	3	2	1	0
TCIR	WCOL	SS_HIGH	-	-	SSENA	TXENA	RXENA
R	R	RW	-	-	RW	RW	RW

Initial value : 00H

**TCIR** When a serial data transmission is complete, the TCIR bit is set. If the SPI interrupt is enabled, an interrupt is requested. And TCIR bit is cleared by hardware when executing the corresponding interrupt. If SPI interrupt is disable, TCIR bit is cleared when user read the status register SPISR, and then access (read/write) the data register SPIDR.

0 Interrupt cleared  
1 Transmission Complete and Interrupt Requested

**WCOL** This bit is set if the data register SPIDR is written during a data transfer. This bit is cleared when user read the status register SPISR, and then access (read/write) the data register SPIDR.

0 No collision  
1 Write Collision

**SS\_HIGH** When SS pin is configured as input(master or slave), if 'HIGH' signal come into SS pin, this flag bit will be set at the SS rising time. And you can clear it by writing '0'.  
You can write only zero.

0 Flag is cleared  
1 Flag is set

**SSENA** This bit controls the SS pin operation

0 Disable  
1 Enable

**TXENA** This bit controls a data transfer operation

0 Disable  
1 Enable

**RXENA** This bit controls a data reception operation

0 Disable  
1 Enable

## 11.9 I<sup>2</sup>C

### 11.9.1 Overview

The I<sup>2</sup>C is one of industrial standard serial communication protocols, and which uses 2 bus lines Serial Data Line (SDA) and Serial Clock Line (SCL) to exchange data. Because both SDA and SCL lines are open-drain output, each line needs pull-up resistor. The features are as shown below.

- Compatible with I<sup>2</sup>C bus standard
- Multi-master operation
- Up to 400 KHz data transfer speed
- 7 bit address
- Support 2 slave addresses
- Both master and slave operation
- Bus busy detection

### 11.9.2 Block Diagram

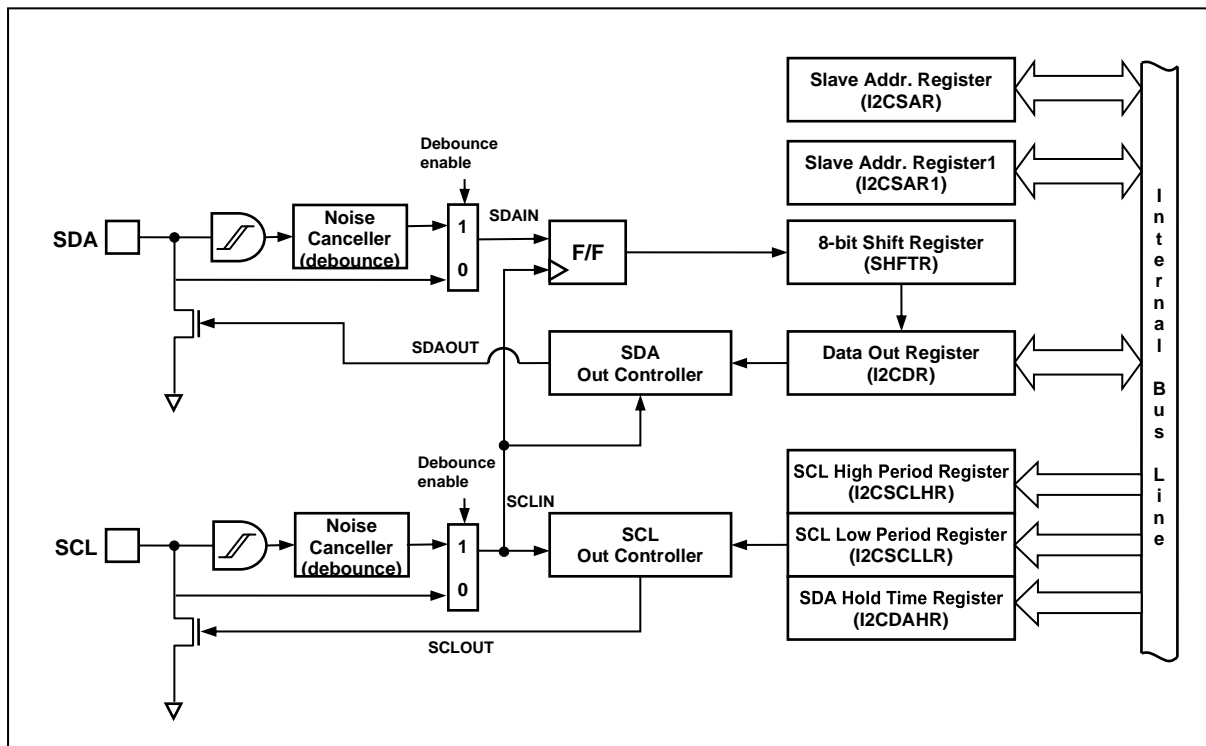

Figure 11.34 I<sup>2</sup>C Block Diagram

### 11.9.3 I<sup>2</sup>C Bit Transfer

The data on the SDA line must be stable during HIGH period of the clock, SCL. The HIGH or LOW state of the data line can only change when the clock signal on the SCL line is LOW. The exceptions are START(S), repeated START(Sr) and STOP(P) condition where data line changes when clock line is high.

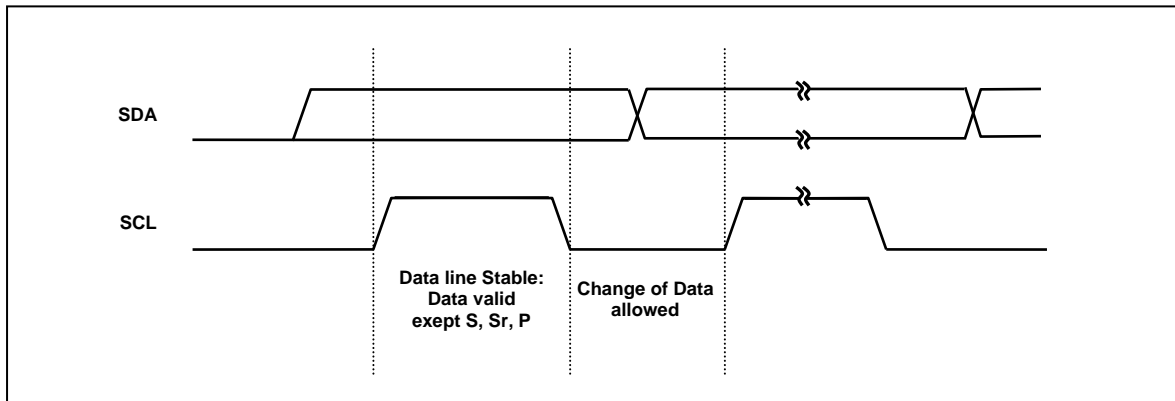

Figure 11.35 Bit Transfer on the I<sup>2</sup>C-Bus

### 11.9.4 Start / Repeated Start / Stop

One master can issue a START (S) condition to notice other devices connected to the SCL, SDA lines that it will use the bus. A STOP (P) condition is generated by the master to release the bus lines so that other devices can use it.

A high to low transition on the SDA line while SCL is high defines a START (S) condition.

A low to high transition on the SDA line while SCL is high defines a STOP (P) condition.

START and STOP conditions are always generated by the master. The bus is considered to be busy after START condition. The bus is considered to be free again after STOP condition, ie, the bus is busy between START and STOP condition. If a repeated START condition (Sr) is generated instead of STOP condition, the bus stays busy. So, the START and repeated START conditions are functionally identical.

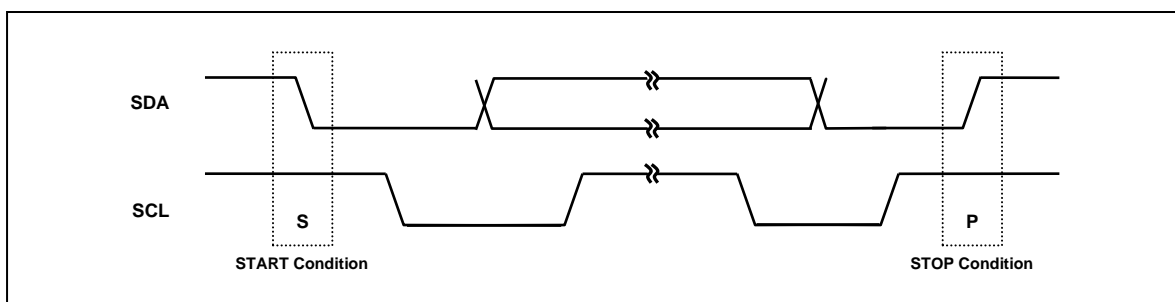

Figure 11.36 START and STOP Condition

### 11.9.5 Data Transfer

Every byte put on the SDA line must be 8-bits long. The number of bytes that can be transmitted per transfer is unlimited. Each byte has to be followed by an acknowledge bit. Data is transferred with the most significant bit (MSB) first. If a slave can't receive or transmit another complete byte of data until it has performed some other function, it can hold the clock line SCL LOW to force the master into a wait state. Data transfer then continues when the slave is ready for another byte of data and releases clock line SCL.



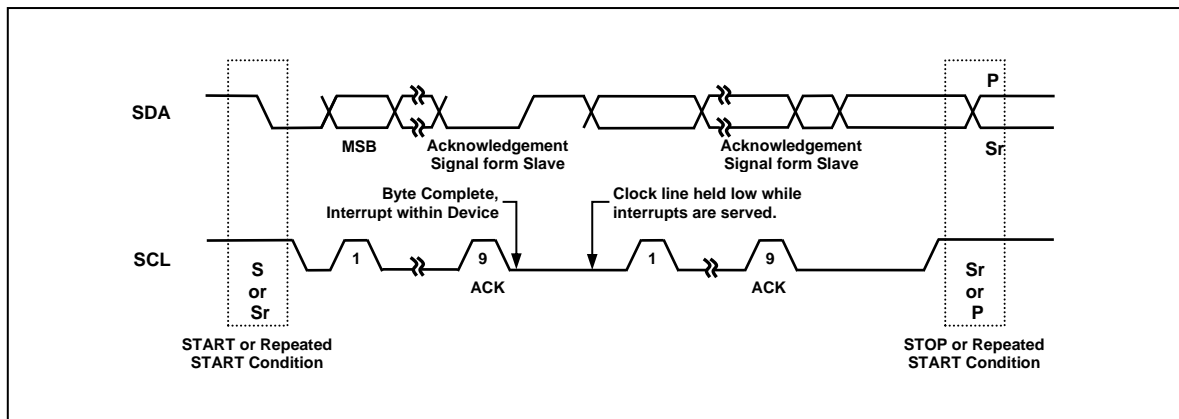

Figure 11.37 Data Transfer on the I<sup>2</sup>C-Bus

### 11.9.6 Acknowledge

The acknowledge related clock pulse is generated by the master. The transmitter releases the SDA line (HIGH) during the acknowledge clock pulse. The receiver must pull down the SDA line during the acknowledge clock pulse so that it remains stable LOW during the HIGH period of this clock pulse. When a slave is addressed by a master (Address Packet), and if it is unable to receive or transmit because it's performing some real time function, the data line must be left HIGH by the slave. And also, when a slave addressed by a master is unable to receive more data bits, the slave receiver must release the SDA line (Data Packet). The master can then generate either a STOP condition to abort the transfer, or a repeated START condition to start a new transfer.

If a master receiver is involved in a transfer, it must signal the end of data to the slave transmitter by not generating an acknowledge on the last byte that was clocked out of the slave. The slave transmitter must release the data line to allow the master to generate a STOP or repeated START condition.

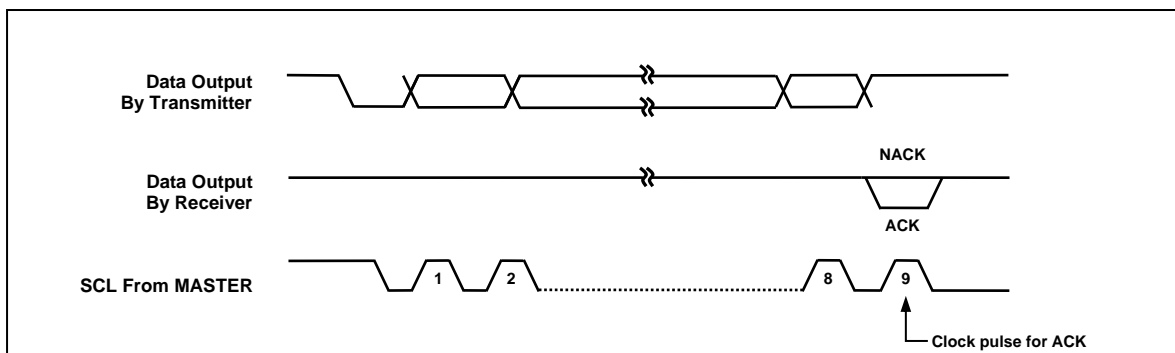

Figure 11.38 Acknowledge on the I<sup>2</sup>C-Bus

### 11.9.7 Synchronization / Arbitration

Clock synchronization is performed using the wired-AND connection of I<sup>2</sup>C interfaces to the SCL line. This means that a HIGH to LOW transition on the SCL line will cause the devices concerned to start counting off their LOW period and it will hold the SCL line in that state until the clock HIGH state is reached. However the LOW to HIGH transition of this clock may not change the state of the SCL line if another clock is still within its LOW period. In this way, a synchronized SCL clock is generated with its

LOW period determined by the device with the longest clock LOW period, and its HIGH period determined by the one with the shortest clock HIGH period.

A master may start a transfer only if the bus is free. Two or more masters may generate a START condition. Arbitration takes place on the SDA line, while the SCL line is at the HIGH level, in such a way that the master which transmits a HIGH level, while another master is transmitting a LOW level will switch off its DATA output state because the level on the bus doesn't correspond to its own level. Arbitration continues for many bits until a winning master gets the ownership of I<sup>2</sup>C bus. Its first stage is comparison of the address bits.

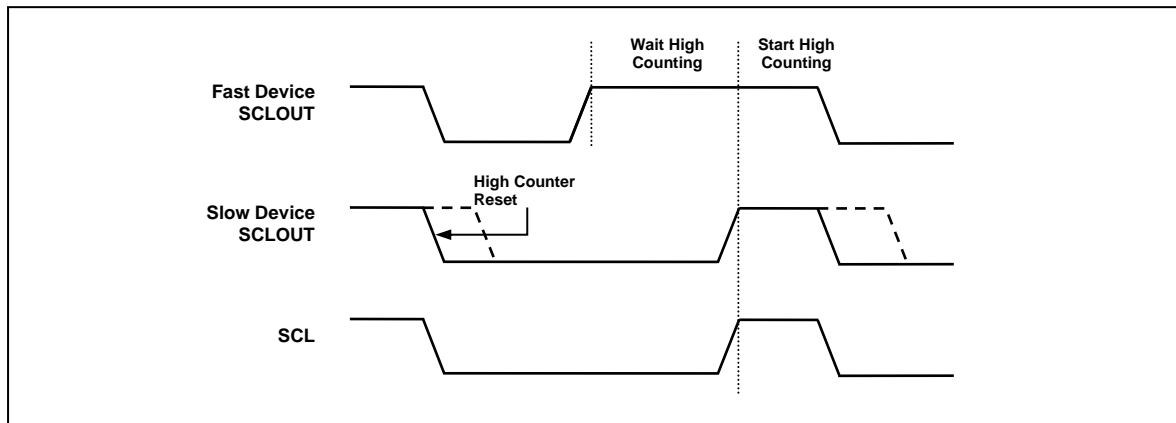

Figure 11.39 Clock Synchronization during Arbitration Procedure

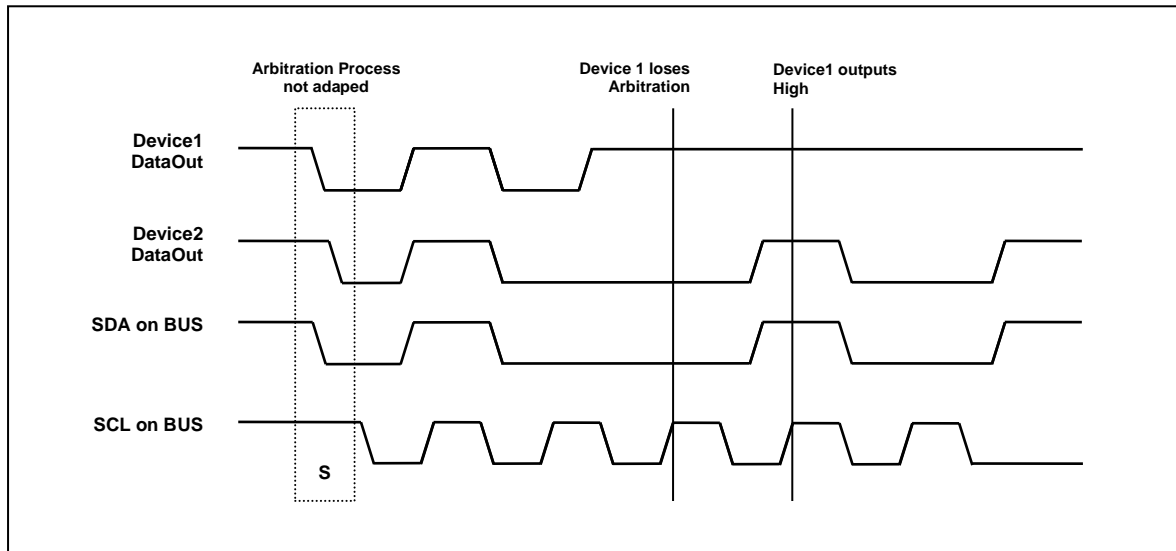

Figure 11.40 Arbitration Procedure of Two Masters

### 11.9.8 Operation

The I<sup>2</sup>C is byte-oriented and interrupt based. Interrupts are issued after all bus events except for a transmission of a START condition. Because the I<sup>2</sup>C is interrupt based, the application software is free to carry on other operations during a I<sup>2</sup>C byte transfer.

Note that when a I<sup>2</sup>C interrupt is generated, IIF flag in I2CMR register is set, it is cleared by writing an arbitrary value to I2CSR. When I<sup>2</sup>C interrupt occurs, the SCL line is hold LOW until writing any value

to I2CSR. When the IIF flag is set, the I2CSR contains a value indicating the current state of the I<sup>2</sup>C bus. According to the value in I2CSR, software can decide what to do next.

I<sup>2</sup>C can operate in 4 modes by configuring master/slave, transmitter/receiver. The operating mode is configured by a winning master. A more detailed explanation follows below.

### 11.9.8.1 Master Transmitter

To operate I<sup>2</sup>C in master transmitter, follow the recommended steps below.

1. Enable I<sup>2</sup>C by setting IICEN bit in I2CMR. This provides main clock to the peripheral.
2. Load SLA+W into the I2CDR where SLA is address of slave device and W is transfer direction from the viewpoint of the master. For master transmitter, W is '0'. Note that I2CDR is used for both address and data.
3. Configure baud rate by writing desired value to both I2CSCLLR and I2CSCLHR for the Low and High period of SCL line.
4. Configure the I2CSDAHR to decide when SDA changes value from falling edge of SCL. If SDA should change in the middle of SCL LOW period, load half the value of I2CSCLLR to the I2CSDAHR.
5. Set the START bit in I2CMR. This transmits a START condition. And also configure how to handle interrupt and ACK signal. When the START bit is set, 8-bit data in I2CDR is transmitted out according to the baud-rate.
6. This is ACK signal processing stage for address packet transmitted by master. When 7-bit address and 1-bit transfer direction is transmitted to target slave device, the master can know whether the slave acknowledged or not in the 9<sup>th</sup> high period of SCL. If the master gains bus mastership, I<sup>2</sup>C generates GCALL interrupt regardless of the reception of ACK from the slave device. When I<sup>2</sup>C loses bus mastership during arbitration process, the MLOST bit in I2CSR is set, and I<sup>2</sup>C waits in idle state or can be operate as an addressed slave. To operate as a slave when the MLSOT bit in I2CSR is set, the ACKEN bit in I2CMR must be set and the received 7-bit address must equal to the SLA bits in I2CSAR. In this case I<sup>2</sup>C operates as a slave transmitter or a slave receiver (go to appropriate section). In this stage, I<sup>2</sup>C holds the SCL LOW. This is because to decide whether I<sup>2</sup>C continues serial transfer or stops communication. The following steps continue assuming that I<sup>2</sup>C does not lose mastership during first data transfer.

I<sup>2</sup>C (Master) can choose one of the following cases regardless of the reception of ACK signal from slave.

- 1) Master receives ACK signal from slave, so continues data transfer because slave can receive more data from master. In this case, load data to transmit to I2CDR.
- 2) Master stops data transfer even if it receives ACK signal from slave. In this case, set the STOP bit in I2CMR.
- 3) Master transmits repeated START condition with not checking ACK signal. In this case, load SLA+R/W into the I2CDR and set START bit in I2CMR.

After doing one of the actions above, write arbitrary value to I2CSR to release SCL line. In case of 1), move to step 7. In case of 2), move to step 9 to handle STOP interrupt. In case of 3), move to step 6 after transmitting the data in I2CDR and if transfer direction bit is '1' go to master receiver section.

7. 1-Byte of data is being transmitted. During data transfer, bus arbitration continues.
8. This is ACK signal processing stage for data packet transmitted by master. I<sup>2</sup>C holds the SCL LOW. When I<sup>2</sup>C loses bus mastership while transmitting data arbitrating other masters, the MLOST bit in I2CSR is set. If then, I<sup>2</sup>C waits in idle state. When the data in I2CDR is transmitted completely, I<sup>2</sup>C generates TEND interrupt.

I<sup>2</sup>C can choose one of the following cases regardless of the reception of ACK signal from slave.

- 1) Master receives ACK signal from slave, so continues data transfer because slave can receive more data from master. In this case, load data to transmit to I2CDR.
- 2) Master stops data transfer even if it receives ACK signal from slave. In this case, set the STOP bit in I2CMR.
- 3) Master transmits repeated START condition with not checking ACK signal. In this case, load SLA+R/W into the I2CDR and set the START bit in I2CMR.

After doing one of the actions above, write arbitrary value to I2CSR to release SCL line. In case of 1), move to step 7. In case of 2), move to step 9 to handle STOP interrupt. In case of 3), move to step 6 after transmitting the data in I2CDR, and if transfer direction bit is '1' go to master receiver section.

9. This is the final step for master transmitter function of I<sup>2</sup>C, handling STOP interrupt. The STOP bit indicates that data transfer between master and slave is over. To clear I2CSR, write arbitrary value to I2CSR. After this, I<sup>2</sup>C enters idle state.



### 11.9.8.2 Master Receiver

To operate I<sup>2</sup>C in master receiver, follow the recommended steps below.

1. Enable I<sup>2</sup>C by setting IICEN bit in I2CMR. This provides main clock to the peripheral.
2. Load SLA+R into the I2CDR where SLA is address of slave device and R is transfer direction from the viewpoint of the master. For master receiver, R is '1'. Note that I2CDR is used for both address and data.
3. Configure baud rate by writing desired value to both I2CSCLLR and I2CSCLHR for the Low and High period of SCL line.
4. Configure the I2CSDAHR to decide when SDA changes value from falling edge of SCL. If SDA should change in the middle of SCL LOW period, load half the value of I2CSCLLR to the I2CSDAHR.
5. Set the START bit in I2CMR. This transmits a START condition. And also configure how to handle interrupt and ACK signal. When the START bit is set, 8-bit data in I2CDR is transmitted out according to the baud-rate.
6. This is ACK signal processing stage for address packet transmitted by master. When 7-bit address and 1-bit transfer direction is transmitted to target slave device, the master can know whether the slave acknowledged or not in the 9<sup>th</sup> high period of SCL. If the master gains bus mastership, I<sup>2</sup>C generates GCALL interrupt regardless of the reception of ACK from the slave device. When I<sup>2</sup>C loses bus mastership during arbitration process, the MLOST bit in I2CSR is set, and I<sup>2</sup>C waits in idle state or can be operate as an addressed slave. To operate as a slave when the MLSOT bit in I2CSR is set, the ACKEN bit in I2CMR must be set and the received 7-bit address must equal to the SLA bits in I2CSAR. In this case I<sup>2</sup>C operates as a slave transmitter or a slave receiver (go to appropriate section). In this stage, I<sup>2</sup>C holds the SCL LOW. This is because to decide whether I<sup>2</sup>C continues serial transfer or stops communication. The following steps continue assuming that I<sup>2</sup>C does not lose mastership during first data transfer.

I<sup>2</sup>C (Master) can choose one of the following cases according to the reception of ACK signal from slave.

- 1) Master receives ACK signal from slave, so continues data transfer because slave can prepare and transmit more data to master. Configure ACKEN bit in I2CMR to decide whether I<sup>2</sup>C ACKnowledges the next data to be received or not.
- 2) Master stops data transfer because it receives no ACK signal from slave. In this case, set the STOP bit in I2CMR.
- 3) Master transmits repeated START condition due to no ACK signal from slave. In this case, load SLA+R/W into the I2CDR and set START bit in I2CMR.

After doing one of the actions above, write arbitrary value to I2CSR to release SCL line. In case of 1), move to step 7. In case of 2), move to step 9 to handle STOP interrupt. In case of 3), move to step 6 after transmitting the data in I2CDR and if transfer direction bit is '0' go to master transmitter section.

7. 1-Byte of data is being received.
8. This is ACK signal processing stage for data packet transmitted by slave. I<sup>2</sup>C holds the SCL LOW. When 1-Byte of data is received completely, I<sup>2</sup>C generates TEND interrupt.

I<sup>2</sup>C can choose one of the following cases according to the RXACK flag in I2CSR.

- 1) Master continues receiving data from slave. To do this, set ACKEN bit in I2CMR to ACKnowledge the next data to be received.
- 2) Master wants to terminate data transfer when it receives next data by not generating ACK signal. This can be done by clearing ACKEN bit in I2CMR.
- 3) Because no ACK signal is detected, master terminates data transfer. In this case, set the



### 11.9.8.3 Slave Transmitter

To operate I<sup>2</sup>C in slave transmitter, follow the recommended steps below.

1. If the main operating clock (SCLK) of the system is slower than that of SCL, load value 0x00 into I2CSDAHR to make SDA change within one system clock period from the falling edge of SCL. Note that the hold time of SDA is calculated by SDAH x period of SCLK where SDAH is multiple of number of SCLK coming from I2CSDAHR. When the hold time of SDA is longer than the period of SCLK, I<sup>2</sup>C (slave) cannot transmit serial data properly.
2. Enable I<sup>2</sup>C by setting IICEN bit and INTEN bit in I2CMR. This provides main clock to the peripheral.
3. When a START condition is detected, I<sup>2</sup>C receives one byte of data and compares it with SLA bits in I2CSAR. If the GCALLEN bit in I2CSAR is enabled, I<sup>2</sup>C compares the received data with value 0x00, the general call address.
4. If the received address does not equal to SLA bits in I2CSAR, I<sup>2</sup>C enters idle state ie, waits for another START condition. Else if the address equals to SLA bits and the ACKEN bit is enabled, I<sup>2</sup>C generates SSEL interrupt and the SCL line is held LOW. Note that even if the address equals to SLA bits, when the ACKEN bit is disabled, I<sup>2</sup>C enters idle state. When SSEL interrupt occurs, load transmit data to I2CDR and write arbitrary value to I2CSR to release SCL line.
5. 1-Byte of data is being transmitted.
6. In this step, I<sup>2</sup>C generates TEND interrupt and holds the SCL line LOW regardless of the reception of ACK signal from master. Slave can select one of the following cases.
  - 1) No ACK signal is detected and I<sup>2</sup>C waits STOP or repeated START condition.
  - 2) ACK signal from master is detected. Load data to transmit into I2CDR.

After doing one of the actions above, write arbitrary value to I2CSR to release SCL line. In case of 1) move to step 7 to terminate communication. In case of 2) move to step 5. In either case, a repeated START condition can be detected. For that case, move step 4.

7. This is the final step for slave transmitter function of I<sup>2</sup>C, handling STOP interrupt. The STOP bit indicates that data transfer between master and slave is over. To clear I2CSR, write arbitrary value to I2CSR. After this, I<sup>2</sup>C enters idle state.



The next figure shows flow chart for handling slave transmitter function of I<sup>2</sup>C.

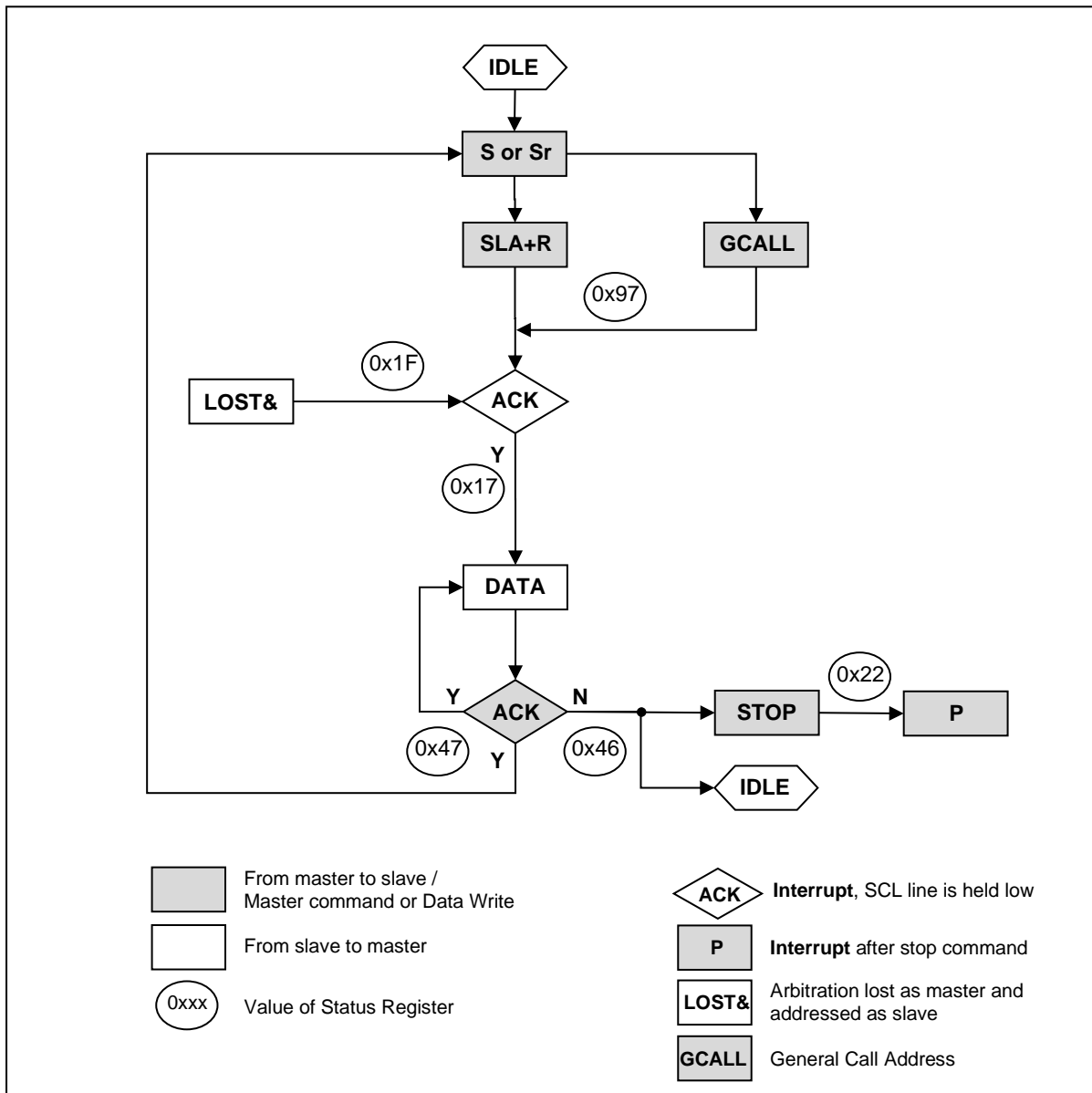

Figure 11.43 Formats and States in the Slave Transmitter Mode

#### 11.9.8.4 Slave Receiver

To operate I<sup>2</sup>C in slave receiver, follow the recommended steps below.

1. If the main operating clock (SCLK) of the system is slower than that of SCL, load value 0x00 into I2CSDAHR to make SDA change within one system clock period from the falling edge of SCL. Note that the hold time of SDA is calculated by SDAH x period of SCLK where SDAH is multiple of number of SCLK coming from I2CSDAHR. When the hold time of SDA is longer than the period of SCLK, I<sup>2</sup>C (slave) cannot transmit serial data properly.
2. Enable I<sup>2</sup>C by setting IICEN bit and INTEN bit in I2CMR. This provides main clock to the peripheral.

3. When a START condition is detected, I<sup>2</sup>C receives one byte of data and compares it with SLA bits in I2CSAR. If the GCALLEN bit in I2CSAR is enabled, I<sup>2</sup>C compares the received data with value 0x00, the general call address.
4. If the received address does not equal to SLA bits in I2CSAR, I<sup>2</sup>C enters idle state ie, waits for another START condition. Else if the address equals to SLA bits and the ACKEN bit is enabled, I<sup>2</sup>C generates SSEL interrupt and the SCL line is held LOW. Note that even if the address equals to SLA bits, when the ACKEN bit is disabled, I<sup>2</sup>C enters idle state. When SSEL interrupt occurs and I<sup>2</sup>C is ready to receive data, write arbitrary value to I2CSR to release SCL line.
5. 1-Byte of data is being received.
6. In this step, I<sup>2</sup>C generates TEND interrupt and holds the SCL line LOW regardless of the reception of ACK signal from master. Slave can select one of the following cases.
  - 1) No ACK signal is detected (ACKEN=0) and I<sup>2</sup>C waits STOP or repeated START condition.
  - 2) ACK signal is detected (ACKEN=1) and I<sup>2</sup>C can continue to receive data from master.

After doing one of the actions above, write arbitrary value to I2CSR to release SCL line. In case of 1) move to step 7 to terminate communication. In case of 2) move to step 5. In either case, a repeated START condition can be detected. For that case, move step 4.
7. This is the final step for slave receiver function of I<sup>2</sup>C, handling STOP interrupt. The STOP bit indicates that data transfer between master and slave is over. To clear I2CSR, write arbitrary value to I2CSR. After this, I<sup>2</sup>C enters idle state.

The process can be depicted as following figure when I<sup>2</sup>C operates in slave receiver mode.

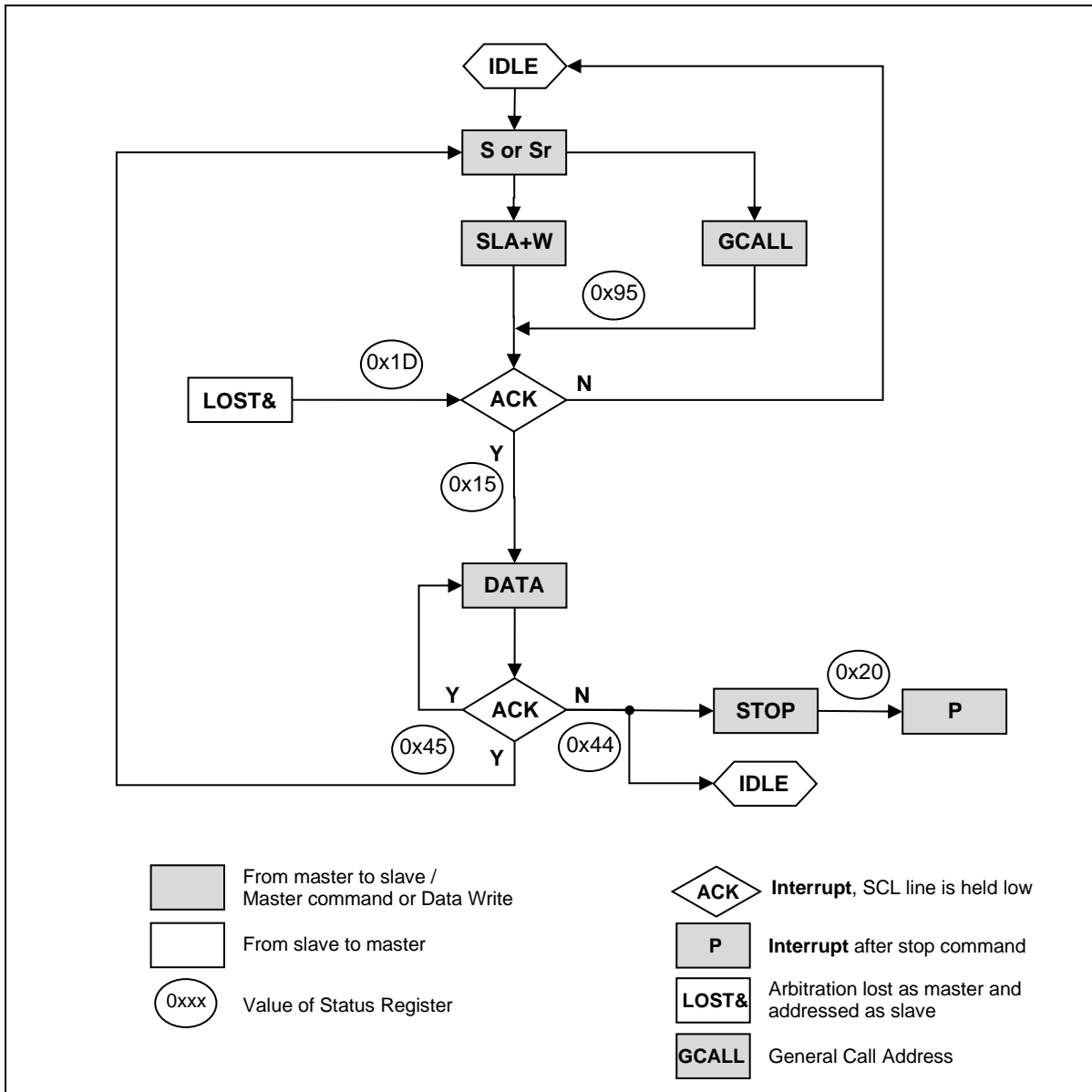

Figure 11.44 Formats and States in the Slave Receiver Mode

11.9.9 Register Map

Name	Address	Dir	Default	Description
I2CMR	DAH	R/W	00H	I <sup>2</sup> C Mode Control Register
I2CSR	DBH	R	00H	I <sup>2</sup> C Status Register
I2CSCLLR	DCH	R/W	3FH	SCL Low Period Register
I2CSCLHR	DDH	R/W	3FH	SCL High Period Register
I2CSDAHR	DEH	R/W	01H	SDA Hold Time Register
I2CDR	DFH	R/W	FFH	I <sup>2</sup> C Data Register
I2CSAR	D7H	R/W	00H	I <sup>2</sup> C Slave Address Register
I2CSAR1	D6H	R/W	00H	I <sup>2</sup> C Slave Address Register 1

### 11.9.10 I<sup>2</sup>C Register description

I<sup>2</sup>C Registers are composed of I<sup>2</sup>C Mode Control Register (I2CMR), I<sup>2</sup>C Status Register (I2CSR), SCL Low Period Register (I2CSCLLR), SCL High Period Register (I2CSCLHR), SDA Hold Time Register (I2CSDAHR), I<sup>2</sup>C Data Register (I2CDR), and I<sup>2</sup>C Slave Address Register (I2CSAR).

### 11.9.11 Register description for I<sup>2</sup>C

#### I2CMR (I<sup>2</sup>C Mode Control Register) : DAH

7	6	5	4	3	2	1	0
IIF	IICEN	RESET	INTEN	ACKEN	MASTER	STOP	START
RW	R/W	RW	RW	RW	R	RW	RW

Initial value : 00H

<b>IIF</b>	This is interrupt flag bit. 0 No interrupt is generated or interrupt is cleared 1 An interrupt is generated
<b>IICEN</b>	Enable I <sup>2</sup> C Function Block (by providing clock) 0 I <sup>2</sup> C is inactive 1 I <sup>2</sup> C is active
<b>RESET</b>	Initialize internal registers of I <sup>2</sup> C. 0 No operation 1 Initialize I <sup>2</sup> C, auto cleared
<b>INTEN</b>	Enable interrupt generation of I <sup>2</sup> C. 0 Disable interrupt, operates in polling mode 1 Enable interrupt
<b>ACKEN</b>	Controls ACK signal generation at ninth SCL period. Note) ACK signal is output (SDA=0) for the following 3 cases. When received address packet equals to SLA bits in I2CSAR When received address packet equals to value 0x00 with GCALL enabled When I <sup>2</sup> C operates as a receiver (master or slave) 0 No ACK signal is generated (SDA=1) 1 ACK signal is generated (SDA=0)
<b>MASTER</b>	Represent operating mode of I <sup>2</sup> C 0 I <sup>2</sup> C is in slave mode 1 I <sup>2</sup> C is in master mode
<b>STOP</b>	When I <sup>2</sup> C is master, generates STOP condition. 0 No operation 1 STOP condition is to be generated
<b>START</b>	When I <sup>2</sup> C is master, generates START condition. 0 No operation 1 START or repeated START condition is to be generated

**I2CSR (I<sup>2</sup>C Status Register) : DBH**

7	6	5	4	3	2	1	0
GCALL	TEND	STOP	SSEL	MLOST	BUSY	TMODE	RXACK
R	R	R	R	R	R	R	R

Initial value : 00H

- GCALL** This bit has different meaning depending on whether I<sup>2</sup>C is master or slave. Note 1)  
 When I<sup>2</sup>C is a master, this bit represents whether it received AACK (Address ACK) from slave.  
 When I<sup>2</sup>C is a slave, this bit is used to indicate general call.  
 0 No AACK is received (Master mode)  
 1 AACK is received (Master mode)  
 0 Received address is not general call address (Slave mode)  
 1 General call address is detected (Slave mode)
- TEND** This bit is set when 1-Byte of data is transferred completely. Note 1)  
 0 1 byte of data is not completely transferred  
 1 1 byte of data is completely transferred
- STOP** This bit is set when STOP condition is detected. Note 1)  
 0 No STOP condition is detected  
 1 STOP condition is detected
- SSEL** This bit is set when I<sup>2</sup>C is addressed by other master. Note 1)  
 0 I<sup>2</sup>C is not selected as slave  
 1 I<sup>2</sup>C is addressed by other master and acts as a slave
- MLOST** This bit represents the result of bus arbitration in master mode. Note 1)  
 0 I<sup>2</sup>C maintains bus mastership  
 1 I<sup>2</sup>C has lost bus mastership during arbitration process
- BUSY** This bit reflects bus status.  
 0 I<sup>2</sup>C bus is idle, so any master can issue a START condition  
 1 I<sup>2</sup>C bus is busy
- TMODE** This bit is used to indicate whether I<sup>2</sup>C is transmitter or receiver.  
 0 I<sup>2</sup>C is a receiver  
 1 I<sup>2</sup>C is a transmitter
- RXACK** This bit shows the state of ACK signal.  
 0 No ACK is received  
 1 ACK is generated at ninth SCL period

Note 1) These bits can be source of interrupt.

When an I<sup>2</sup>C interrupt occurs except for STOP interrupt, the SCL line is hold LOW. To release SCL, write arbitrary value to I2CSR. When I2CSR is written, the TEND, STOP, SSEL, LOST, RXACK bits are cleared.

**I2CSCLR (SCL Low Period Register) : DCH**

7	6	5	4	3	2	1	0
SCLL7	SCLL6	SCLL5	SCLL4	SCLL3	SCLL2	SCLL1	SCLL0
RW	RW	RW	RW	RW	RW	RW	RW

Initial value : 3FH

**SCLL[7:0]** This register defines the LOW period of SCL when I<sup>2</sup>C operates in master mode. The base clock is SCLK, the system clock, and the period is calculated by the formula :  $t_{SCLK} \times (4 \times SCLL + 1)$  where  $t_{SCLK}$  is the period of SCLK.

#### I<sup>2</sup>C SCLHR (SCL High Period Register) : DDH

7	6	5	4	3	2	1	0
SCLH7	SCLH6	SCLH5	SCLH4	SCLH3	SCLH2	SCLH1	SCLH0
RW	RW	RW	RW	RW	RW	RW	RW

Initial value : 3FH

**SCLH[7:0]** This register defines the HIGH period of SCL when I<sup>2</sup>C operates in master mode. The base clock is SCLK, the system clock, and the period is calculated by the formula :  $t_{SCLK} \times (4 \times SCLH + 3)$  where  $t_{SCLK}$  is the period of SCLK.

So, the operating frequency of I<sup>2</sup>C in master mode (fI<sup>2</sup>C) is calculated by the following equation.

$$fI^2C = \frac{1}{t_{SCLK} \times (4 (SCLL + SCLH) + 4)}$$

#### I<sup>2</sup>C SDAH (SDA Hold Time Register) : DEH

7	6	5	4	3	2	1	0
SDAH7	SDAH6	SDAH5	SDAH4	SDAH3	SDAH2	SDAH1	SDAH0
RW	RW	RW	RW	RW	RW	RW	RW

Initial value : 01H

**SDAH[7:0]** This register is used to control SDA output timing from the falling edge of SCL. Note that SDA is changed after  $t_{SCLK} \times SDAH$ . In master mode, load half the value of SCLL to this register to make SDA change in the middle of SCL. In slave mode, configure this register regarding the frequency of SCL from master. The SDA is changed after  $t_{SCLK} \times (SDAH + 1)$ . So, to insure normal operation in slave mode, the value  $t_{SCLK} \times (SDAH + 1)$  must be smaller than the period of SCL.

#### I<sup>2</sup>C CDR (I<sup>2</sup>C Data Register) : DFH

7	6	5	4	3	2	1	0
ICD7	ICD6	ICD5	ICD4	ICD3	ICD2	ICD1	ICD0
RW	RW	RW	RW	RW	RW	RW	RW

Initial value : FFH

**ICD[7:0]** When I<sup>2</sup>C is configured as a transmitter, load this register with data to be transmitted. When I<sup>2</sup>C is a receiver, the received data is stored into this register.

#### I<sup>2</sup>C SAR (I<sup>2</sup>C Slave Address Register) : D7H

7	6	5	4	3	2	1	0
SLA7	SLA6	SLA5	SLA4	SLA3	SLA2	SLA1	GCALLEN
RW	RW	RW	RW	RW	RW	RW	RW

Initial value : 00H

**SLA[7:1]** These bits configure the slave address of this I<sup>2</sup>C module when I<sup>2</sup>C operates in slave mode.

**GCALLEN** This bit decides whether I<sup>2</sup>C allows general call address or not when I<sup>2</sup>C operates in slave mode.

0 Ignore general call address

1 Allow general call address

**I2CSAR1 (I<sup>2</sup>C Slave Address Register 1) : D6H**

7	6	5	4	3	2	1	0
SLA7	SLA6	SLA5	SLA4	SLA3	SLA2	SLA1	GCALLEN
RW	RW	RW	RW	RW	RW	RW	RW

Initial value : 00H

**SLA[7:1]** These bits configure the slave address of this I<sup>2</sup>C module when I<sup>2</sup>C operates in slave mode.

**GCALLEN** This bit decides whether I<sup>2</sup>C allows general call address or not when I<sup>2</sup>C operates in slave mode.

0 Ignore general call address

1 Allow general call address

## 11.10 12-Bit A/D Converter

### 11.10.1 Overview

The analog-to-digital converter (A/D) allows conversion of an analog input signal to a corresponding 12-bit digital value. The A/D module has tenth analog inputs. The output of the multiplex is the input into the converter, which generates the result via successive approximation. The A/D module has four registers which are the control register ADCM (A/D Converter Mode Register), ADCM2 (A/D Converter Mode Register 2) and A/D result register ADCHR (A/D Converter Result High Register) and ADCLR (A/D Converter Result Low Register). It is selected for the corresponding channel to be converted by setting ADSEL[3:0]. To executing A/D conversion, ADST bit sets to '1'. The register ADCHR and ADCLR contains the results of the A/D conversion. When the conversion is completed, the result is loaded into the ADCHR and ADCLR, the A/D conversion status bit AFLAG is set to '1', and the A/D interrupt is set. For processing A/D conversion, AFLAG bit is read as '0'. If using STBY (power down) bit, the ADC is disabled. Also internal timer, external generating event, comparator, the trigger of timer1pwm and etc. can start ADC regardless of interrupt occurrence.

$$\text{ADC Conversion Time} = \text{ADCLK} * 60 \text{ cycles}$$

After STBY bit is reset (ADC power enable) and it is restarted, during some cycle, ADC conversion value may have an inaccurate value.

### 11.10.2 Block Diagram

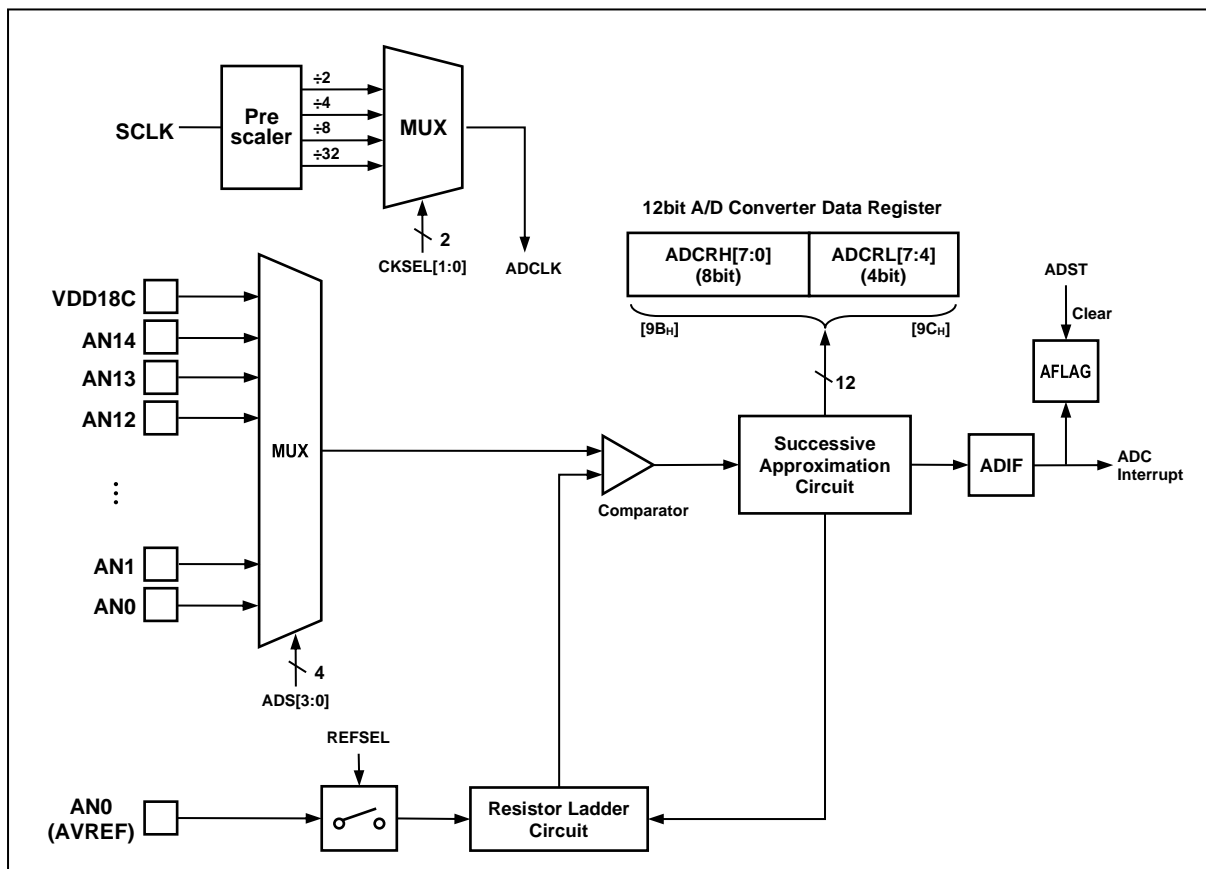

Figure 11.45 ADC Block Diagram



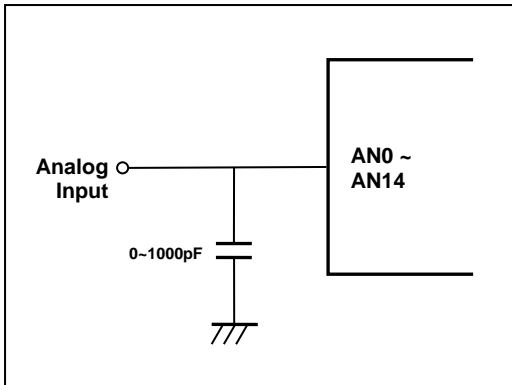

Figure 11.46 A/D Analog Input Pin Connecting Capacitor

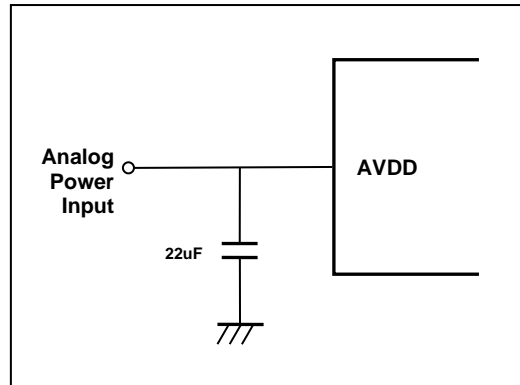

Figure 11.47 A/D Power(AVDD) Pin Connecting Capacitor

### 11.10.3 ADC Operation

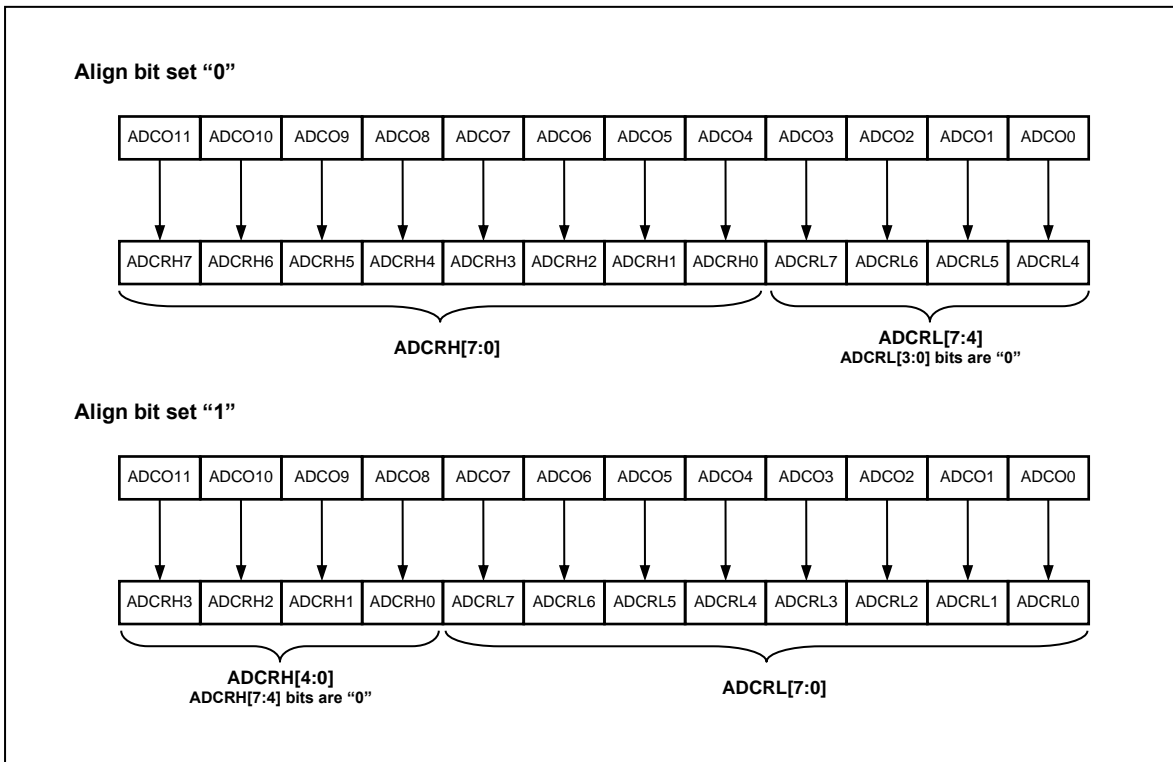

Figure 11.48 ADC Operation for Align bit

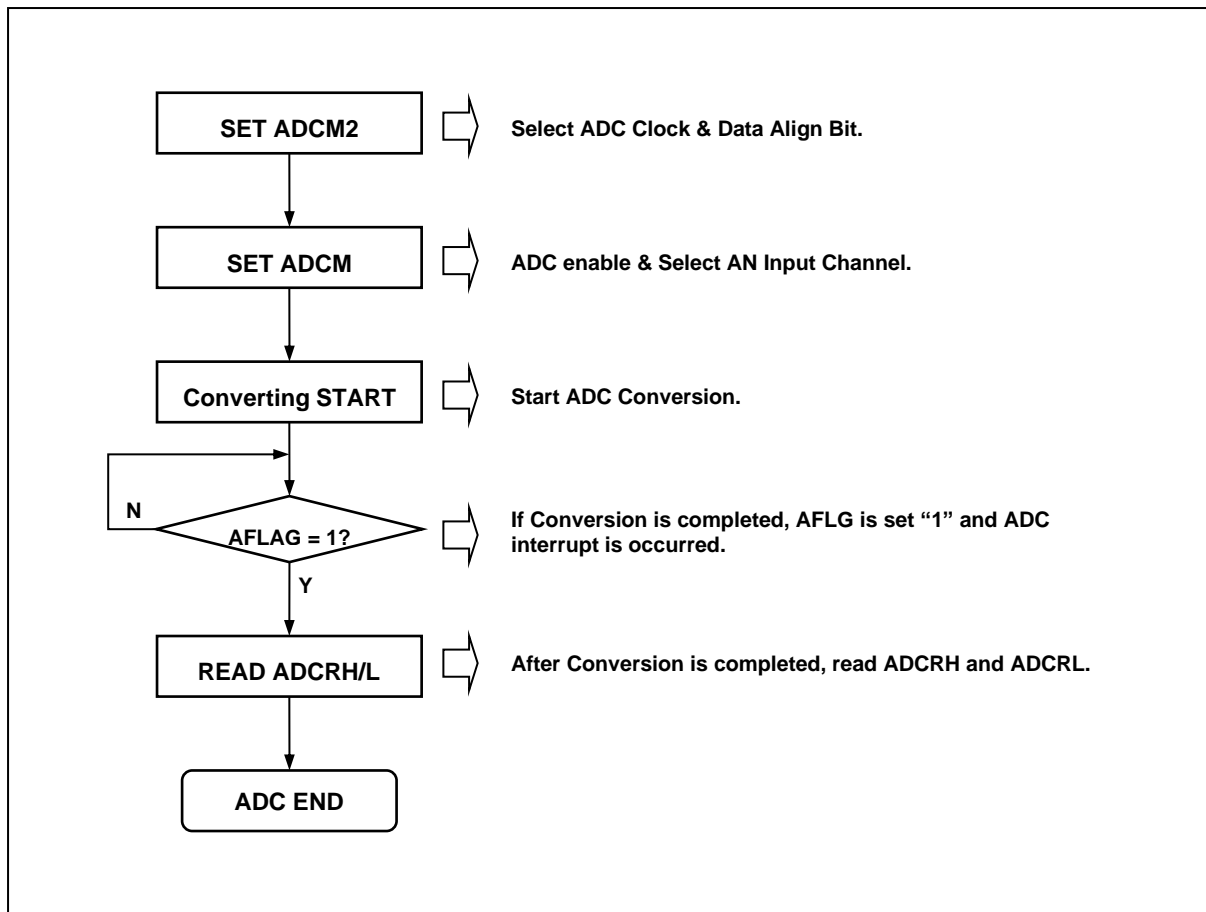

Figure 11.49 Converter Operation Flow

### 11.10.4 Register Map

Name	Address	Dir	Default	Description
ADCM	9AH	R/W	8FH	A/D Converter Mode Register
ADCRH	9BH	R	-	A/D Converter Result High Register
ADCRL	9CH	R	-	A/D Converter Result Low Register
ADCM2	9BH	R/W	8FH	A/D Converter Mode 2 Register

### 11.10.5 ADC Register description

The ADC Register consists of A/D Converter Mode Register (ADCM), A/D Converter Result High Register (ADCRH), A/D Converter Result Low Register (ADCRL), A/D Converter Mode 2 Register (ADCM2).

Note) when STBY bit is set to '1', ADCM2 can be read. If ADC enables, it is possible only to write ADCM2. When reading, ADCRH is read.

### 11.10.6 Register description for ADC

#### ADCM (A/D Converter Mode Register) : 9AH

7	6	5	4	3	2	1	0
STBY	ADST	REFSEL	AFLAG	ADSEL3	ADSEL2	ADSEL1	ADSEL0
RW	RW	RW	R	RW	RW	RW	RW

Initial value : 8FH

<b>STBY</b>	Control operation of A/D standby (power down)				
0	ADC module enable				
1	ADC module disable (power down)				
<b>ADST</b>	Control A/D Conversion stop/start.				
0	ADC Conversion Stop				
1	ADC Conversion Start				
<b>REFSEL</b>	A/D Converter reference selection				
0	Internal Reference (VDD)				
1	External Reference(AVREF, AN0 disable)				
<b>AFLAG</b>	A/D Converter operation state				
0	During A/D Conversion				
1	A/D Conversion finished				
<b>ADSEL[3:0]</b>	A/D Converter input selection				
	ADSEL3	ADSEL2	ADSEL1	ADSEL0	Description
	0	0	0	0	Channel0(AN0)
	0	0	0	1	Channel1(AN1)
	0	0	1	0	Channel2(AN2)
	0	0	1	1	Channel3(AN3)
	0	1	0	0	Channel4(AN4)
	0	1	0	1	Channel5(AN5)
	0	1	1	0	Channel6(AN6)
	0	1	1	1	Channel7(AN7)
	1	0	0	0	Channel8(AN8)
	1	0	0	1	Channel9(AN9)
	1	0	1	0	Channel10(AN10)
	1	0	1	1	Channel11(AN11)
	1	1	0	0	Channel12(AN12)
	1	1	0	1	Channel13(AN13)
	1	1	1	0	Channel14(AN14)
	1	1	1	1	Channel15(VDD18)

#### ADCRH (A/D Converter Result High Register) : 9BH

7	6	5	4	3	2	1	0
ADDM11	ADDM10	ADDM9	ADDM8	ADDM7 ADDL11	ADDM6 ADDL10	ADDM5 ADDL9	ADDM4 ADDL8
R	R	R	R	R	R	R	R

Initial value : xxH

**ADDM[11:4]** MSB align, A/D Converter High result (8-bit)

**ADDL[11:8]** LSB align, A/D Converter High result (4-bit)

### ADCRL (A/D Converter Result Low Register) : 9CH

7	6	5	4	3	2	1	0
ADDM3 ADDL7	ADDM2 ADDL6	ADDM1 ADDL5	ADDM0 ADDL4	ADDL3	ADDL2	ADDL1	ADDL0
R	R	R	R	R	R	R	R

Initial value : xxH

**ADDM[3:0]** MSB align, A/D Converter Low result (4-bit)

**ADDL[7:0]** LSB align, A/D Converter Low result (8-bit)

### ADCM2 (A/D Converter Mode Register) : 9BH

7	6	5	4	3	2	1	0
EXTRG	TSEL2	TSEL1	TSEL0	ADCCK2	ALIGN	CKSEL1	CKSEL0
RW	RW	RW	RW	RW	RW	RW	RW

Initial value : 8FH

**EXTRG** A/D external Trigger

0 External Trigger disable

1 External Trigger enable

**TSEL[2:0]** A/D Trigger Source selection

TSEL2	TSEL1	TSEL0	Description
0	0	0	Ext. Interrupt 0
0	0	1	Ext. Interrupt 1
0	1	0	Pin Change Interrupt 7
0	1	1	Timer0 interrupt event
1	0	0	Timer1 interrupt event
1	0	1	Timer2 interrupt event
1	1	0	Timer3 interrupt event
1	1	1	Timer4 interrupt event

**ADCCK2** A/D Converter Clock selection 2

0 use SCLK(fx) as source of ADC clock selection

1 use (1/2 fx) as source of ADC clock selection with CKSEL

This bit would be needed for higher SCLK frequency than 10MHz

**ALIGN** A/D Converter data align selection.

0 MSB align (ADCRH[7:0], ADCRL[7:4])

1 LSB align (ADCRH[3:0], ADCRL[7:0])

**CKSEL[1:0]** A/D Converter Clock selection

CKSEL1	CKSEL0	ADC Clock	ADC VDD
0	0	fx/2	Test Only
0	1	fx/4	3V~5V
1	0	fx/8	2.7V~3V
1	1	fx/32	2.4V~2.7V

Note) 1. fx : system clock

2. ADC clock have to be used 3MHz under

## 11.11 CALCULATOR\_AI

### 11.11.1 Introduction

The CALCULATOR\_AI block is an integrated version of multiplier and divider data path block. All operation is performed with signed extension (signed multiplication, signed division). The multiplication needs only one clock cycle, but the division is performed during 32 clock cycles. You can use the EOD (End of Division) flag bit to control the division calculation flow. If divisor equals to 0, the DIV\_BY\_0 flag is 1 and the division result is filled with maximum value and the remainder is replaced with the dividend value.

The registers for CALCULATOR\_AI can be indirectly accessed via CAL\_CNTR, CAL\_ADDR, CAL\_DATA to save the SFR area and to increase the code performance. The access address will be automatically incremented when you access to CAL\_DATA (Read/Write).

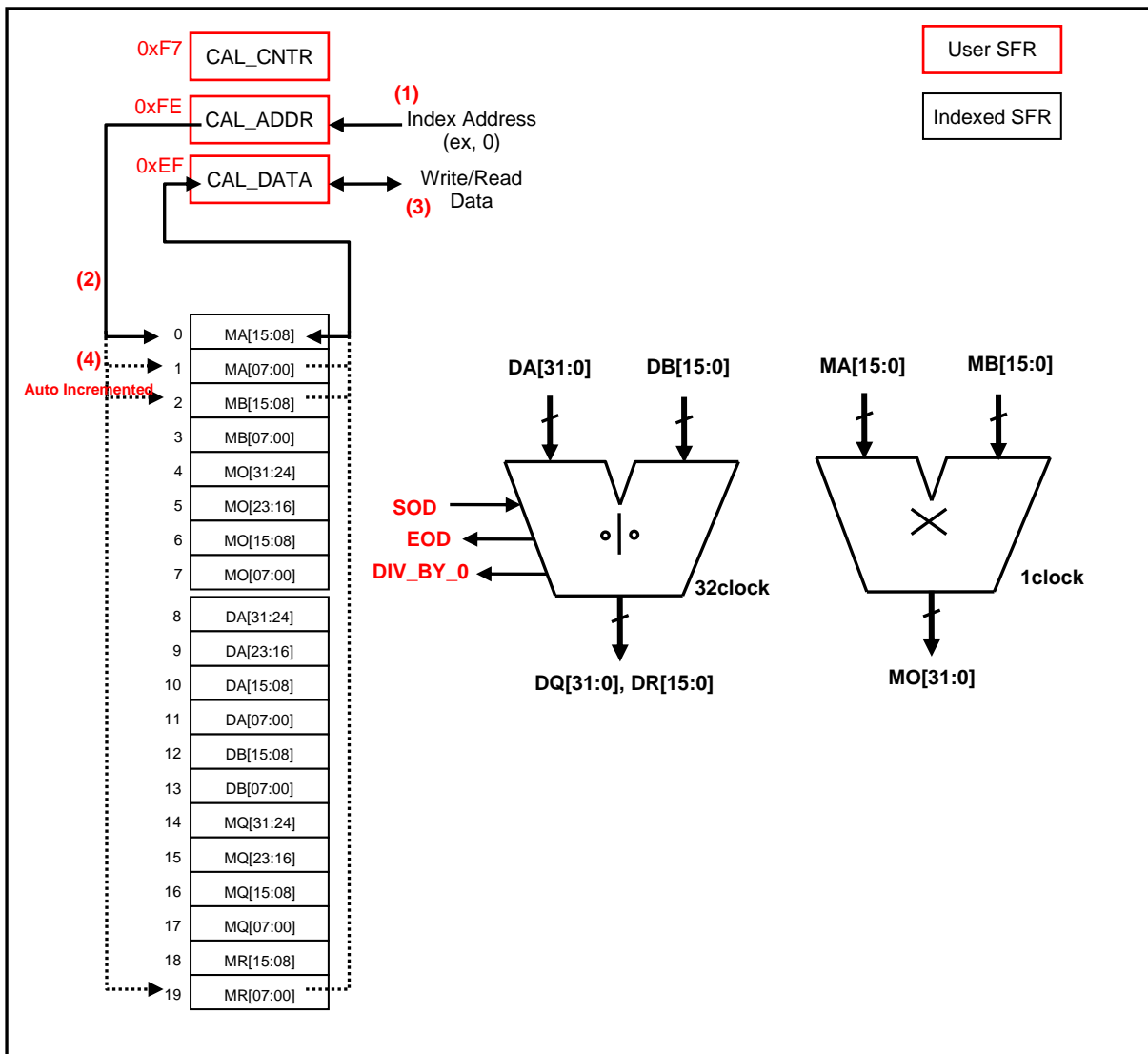

Figure 11.50 Calculator Block Diagram

### 11.11.2 Calculator Registers

#### CAL\_CNTR (Calculator Control Register) : F7H

7	6	5	4	3	2	1	0
-	-	-	-	-	DIV_BY_0	EOD	SOD
-	-	-	-	-	R	R	RW

Initial value : 02H

**DIV\_BY\_0** Indicate if Divisor equals 0

0 Divisor is not 0

1 Divisor is 0

**EOD** End of Division

Note) Multiplication needs only one clock cycle.

Note) Division needs 32 clock cycles

0 During Calculation

1 Idle or End of Calculation

**SOD** Start of Division

Note) SOD bit will be automatically cleared after one clock cycle.

0 Idle

1 Start of Division (auto cleared)

#### CAL\_ADDR (Calculator Control Register) : EH

7	6	5	4	3	2	1	0
CAL_ADDR7	CAL_ADDR6	CAL_ADDR5	CAL_ADDR4	CAL_ADDR3	CAL_ADDR2	CAL_ADDR1	CAL_ADDR0
RW	RW	RW	RW	RW	RW	RW	RW

Initial value : 00H

**CAL\_ADDR[7:0]** Calculator Internal Register Current Address Index Value for Indirect Auto-Incremented Addressing Mode

#### CAL\_DATA (Calculator Control Register) : EFH

7	6	5	4	3	2	1	0
CAL_DATA7	CAL_DATA6	CAL_DATA5	CAL_DATA4	CAL_DATA3	CAL_DATA2	CAL_DATA1	CAL_DATA0
RW	RW	RW	RW	RW	RW	RW	RW

Initial value : 00H

**CAL\_DATA[7:0]** Calculator Internal Register Current Value indexed by CAL\_ADDR address index value

### 11.11.3 Calculator Library

#### 11.11.3.1 Signed Multiplication

```

__sfr __at (0xF7) CAL_CNTR;
__sfr __at (0xEE) CAL_ADDR;
__sfr __at (0xEF) CAL_DATA;

#define CAL_DIV_START 0x01
#define CAL_DIV_DONE 0x02
#define CAL_DIV_BY_0 0x04

long L_mul( short a, short b ) {
    long mul_o;
    mul_o = 0;

    CAL_ADDR = 0;          // currently point to MA[15:8]
    CAL_DATA = a >> 8;    // MA[15:08]<-a[15:08], ADDR<-ADDR+1
    CAL_DATA = a;         // MA[07:00]<-a[07:00], ADDR<-ADDR+1
    CAL_DATA = b >> 8;    // MB[15:08]<-b[15:08], ADDR<-ADDR+1
    CAL_DATA = b;        // MB[07:00]<-b[07:00], ADDR<-ADDR+1

    // now ADDR points to MO[31:24],
    // so just read it
    mul_o = (unsigned long)CAL_DATA<<24; // MO[31:24], ADDR<-ADDR+1
    mul_o |= (unsigned long)CAL_DATA<<16; // MO[23:16], ADDR<-ADDR+1
    mul_o |= (unsigned long)CAL_DATA<<8;  // MO[15:08], ADDR<-ADDR+1
    mul_o |= (unsigned long)CAL_DATA;    // MO[07:00], ADDR<-ADDR+1

    return mul_o;
}
    
```

#### 11.11.3.2 Signed Division

```

__sfr __at (0xF7) CAL_CNTR;
__sfr __at (0xEE) CAL_ADDR;
__sfr __at (0xEF) CAL_DATA;

#define CAL_DIV_START 0x01
#define CAL_DIV_DONE 0x02
    
```

```
#define CAL_DIV_BY_0 0x04

void L_div( long a, short b, long* q, short* r) {
    long div_q;
    short div_r;
    div_q = 0;
    div_r = 0;

    CAL_ADDR = 8;           // currently point to DA[31:24]
    CAL_DATA = a >> 24; // DA[31:24]<-a[31:24], ADDR<-ADDR+1
    CAL_DATA = a >> 16; // DA[23:16]<-a[23:16], ADDR<-ADDR+1
    CAL_DATA = a >> 8;  // DA[15:08]<-a[15:08], ADDR<-ADDR+1
    CAL_DATA = a;       // DA[07:00]<-a[07:00], ADDR<-ADDR+1

    CAL_DATA = b >> 8;  // DB[15:08]<-b[15:08], ADDR<-ADDR+1
    CAL_DATA = b;       // DB[07:00]<-b[07:00], ADDR<-ADDR+1

    while( (CAL_CNTR & CAL_DIV_DONE) == 0);
    // wait until division is done (need 32clock cycles)

    // now ADDR points to DQ[31:24],
    // so just read it
    div_q = (unsigned long)CAL_DATA<<24; // DQ[31:24], ADDR<-ADDR+1
    div_q |= (unsigned long)CAL_DATA<<16; // DQ[23:16], ADDR<-ADDR+1
    div_q |= (unsigned long)CAL_DATA<<8;  // DQ[15:08], ADDR<-ADDR+1
    div_q |= (unsigned long)CAL_DATA;     // DQ[07:00], ADDR<-ADDR+1

    div_r = (unsigned long)CAL_DATA<<8; // DR[15:08], ADDR<-ADDR+1
    div_r |= (unsigned long)CAL_DATA;   // DR[07:00], ADDR<-ADDR+1

    *q = div_q;
    *r = div_r;
}
```



## 12. Power Down Operation

### 12.1 Overview

The MC95FG0128A has three power-down modes to minimize the power consumption of the device. In power down mode, power consumption is reduced considerably. The device provides three kinds of power saving functions, IDLE, STOP1 and STOP2 mode. In three modes, program is stopped.

### 12.2 Peripheral Operation in IDLE/STOP Mode

**Table 12-1 Peripheral Operation during Power Down Mode.**

Peripheral	IDLE Mode	STOP1 Mode	STOP2 Mode
CPU	ALL CPU Operation are Disable	ALL CPU Operation are Disable	ALL CPU Operation are Disable
RAM	Retain	Retain	Retain
Basic Interval Timer	Operates Continuously	Operates Continuously	Stop
Watch Dog Timer	Operates Continuously	Operates Continuously	Stop
Watch Timer	Operates Continuously	Stop (Only operate in sub clock mode)	Stop (Only operate in sub clock mode)
Timer	Operates Continuously	Halted (Only when the Event Counter Mode is Enable, Timer operates Normally)	Halted (Only when the Event Counter Mode is Enable, Timer operates Normally)
ADC	Operates Continuously	Stop	Stop
BUZ	Operates Continuously	Stop	Stop
SPI/SCI	Operates Continuously	Only operate with external clock	Only operate with external clock
I <sup>2</sup> C	Operates Continuously	Stop	Stop
Internal OSC (8MHz)	Oscillation	Stop	Stop
Main OSC (1~10MHz)	Oscillation	Stop	Stop
Sub OSC (32.768kHz)	Oscillation	Oscillation	Oscillation
Internal RCOSC (125kHz)	Oscillation	Oscillation	Stop
I/O Port	Retain	Retain	Retain
Control Register	Retain	Retain	Retain
Address Data Bus	Retain	Retain	Retain
Release Method	By RESET, all Interrupts	By RESET, Timer Interrupt(EC0,2,3,4,5), SIO (External clock), External Interrupt, UART by ACK PCI, I <sup>2</sup> C (slave mode), WT (sub clock),WDT, BIT	By RESET, Timer Interrupt(EC0,2,3,4,5), SIO (External clock), External Interrupt, UART by ACK PCI, I <sup>2</sup> C (slave mode), WT (sub clock)

### 12.3 IDLE mode

The power control register is set to '01h' to enter the IDLE Mode. In this mode, the internal oscillation circuits remain active. Oscillation continues and peripherals are operated normally but CPU stops. It is released by reset or interrupt. To be released by interrupt, interrupt should be enabled before IDLE mode. If using reset, because the device becomes initialized state, the registers have reset value.

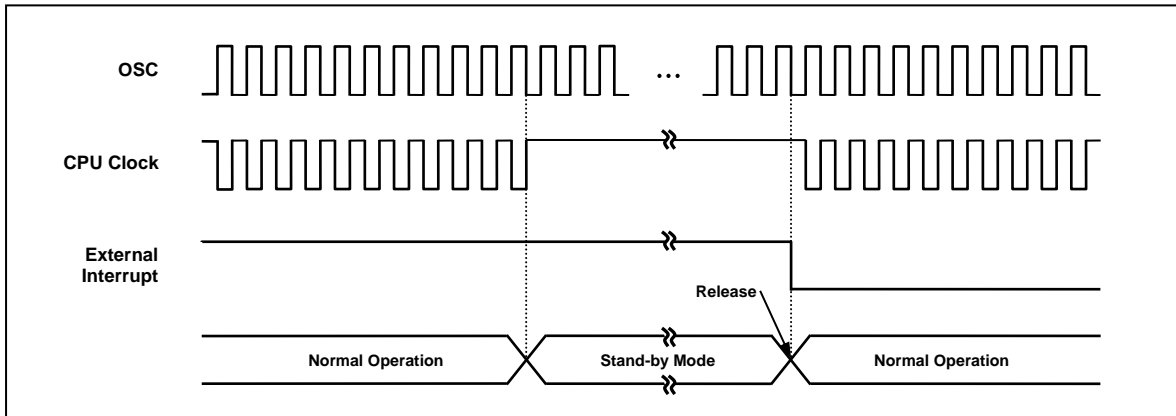

Figure 12.1 IDLE Mode Release Timing by External Interrupt

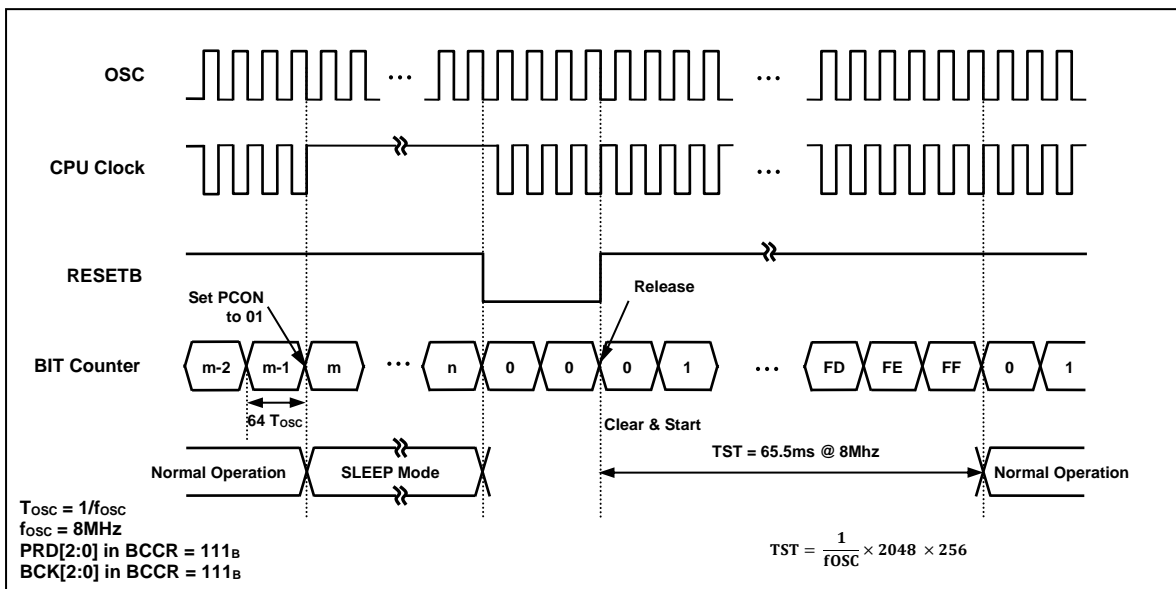

Figure 12.2 IDLE Mode Release Timing by /RESET

(Ex) MOV PCON, #0000\_0001b ; setting of IDLE mode : set the bit of STOP and IDLE Control register (PCON)

### 12.4 STOP mode

The power control register is set to '03h' to enter the STOP Mode. In the stop mode, the main oscillator, system clock and peripheral clock is stopped, but watch timer continue to operate. With the clock frozen, all functions are stooped, but the on-chip RAM and control registers are held.

The source for exit from STOP mode is hardware reset and interrupts. The reset re-defines all the control registers.

When exit from STOP mode, enough oscillation stabilization time is required to normal operation. Figure 12.3 shows the timing diagram. When released from STOP mode, the Basic interval timer is activated on wake-up. Therefore, before STOP instruction, user must be set its relevant prescaler divide ratio to have long enough time (more than 20msec). this guarantees that oscillator has started and stabilized.

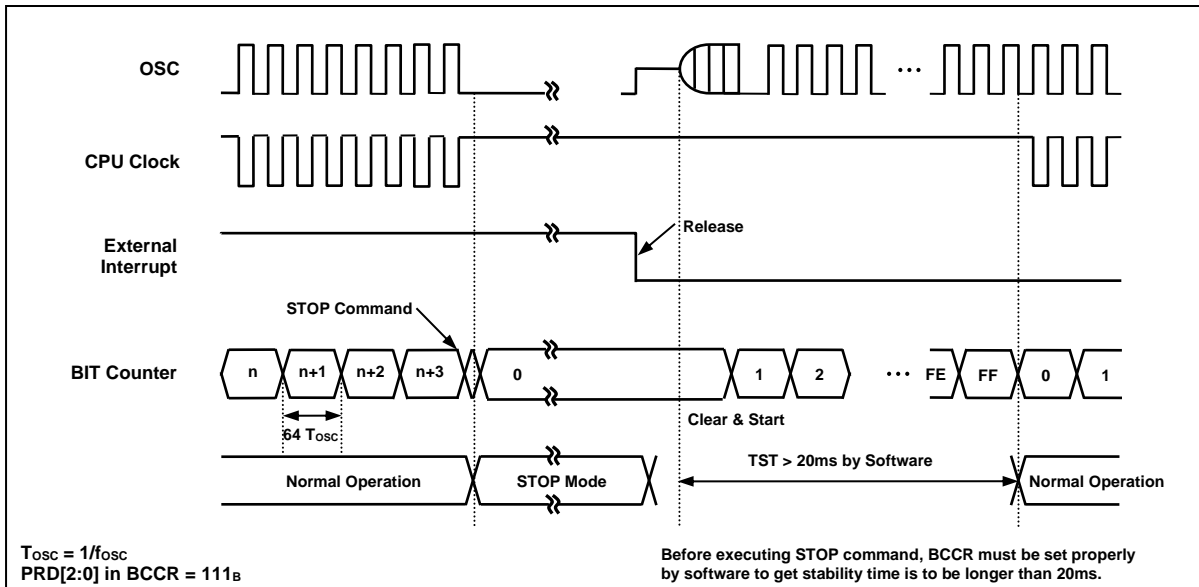

Figure 12.3 STOP Mode Release Timing by External Interrupt

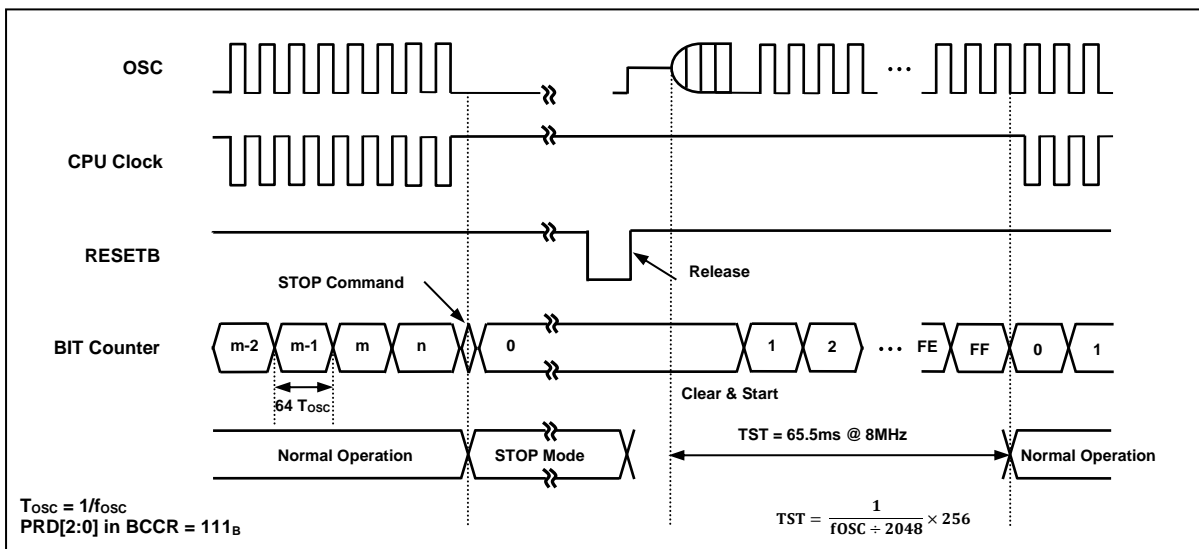

Figure 12.4 STOP Mode Release Timing by /RESET

## 12.5 Release Operation of STOP1, 2 Mode

After STOP1, 2 mode is released, the operation begins according to content of related interrupt register just before STOP1, 2 mode start (Figure 12.5). Interrupt Enable Flag of All (EA) of IE should be set to `1`. Released by only interrupt which each interrupt enable flag = `1`, and jump to the relevant interrupt service routine.

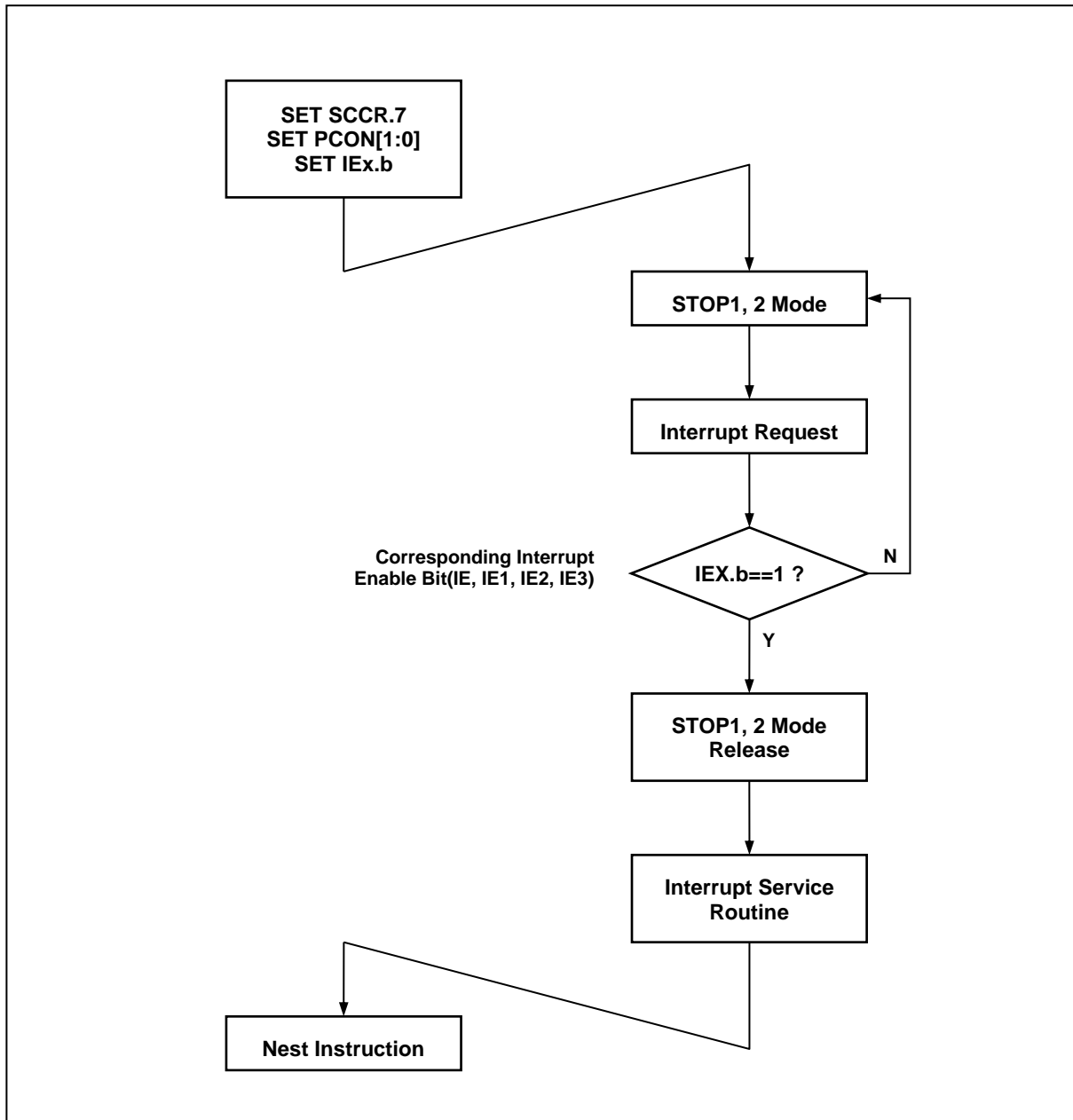

Figure 12.5 STOP1, 2 Mode Release Flow

### 12.5.1 Register Map

**Table 12-2 Register Map**

Name	Address	Dir	Default	Description
PCON	87H	R/W	00H	Power Control Register

### 12.5.2 Power Down Operation Register description

The Power Down Operation Register consists of the Power Control Register (PCON).

### 12.5.3 Register description for Power Down Operation

**PCON (Power Control Register) : 87H**

7	6	5	4	3	2	1	0
bit7	bit6	bit5	bit4	bit3	bit2	bit1	bit0
R/W	R/W	R/W	R/W	R/W	R/W	R/W	R/W

Initial value : 00H

IDLE Mode

01H IDLE mode enable

STOP1, 2 Mode

03H STOP1, 2 mode enable

Note)

- To enter IDLE mode, PCON must be set to '01H'.
- To STOP1,2 mode, PCON must be set to '03H'.  
(In STOP1,2 mode, PCON register is cleared automatically by interrupt or reset)
- When PCON is set to '03H', if SCCR[7] is set to '1', it enters the STOP1 mode. if SCCR[7] is cleared to '0', it enters the STOP2 mode
- The different thing in STOP 1,2 is only clock operation of internal 125kHz-OSC during STOP mode operating.

## 13. RESET

### 13.1 Overview

The MC95FG0128A has reset by external RESETB pin. The following is the hardware setting value.

**Table 13-1 Reset state**

On Chip Hardware	Initial Value
Program Counter (PC)	0000h
Accumulator	00h
Stack Pointer (SP)	07h
Peripheral Clock	On
Control Register	Peripheral Registers refer
Brown-Out Detector	Enable

### 13.2 Reset source

The MC95FG0128A has five types of reset generation procedures. The following is the reset sources.

- External RESETB
- Power ON RESET (POR)
- WDT Overflow Reset (In the case of WDTEN = `1`)
- BOD Reset (In the case of BODEN = `1`)
- OCD Reset

### 13.3 Block Diagram

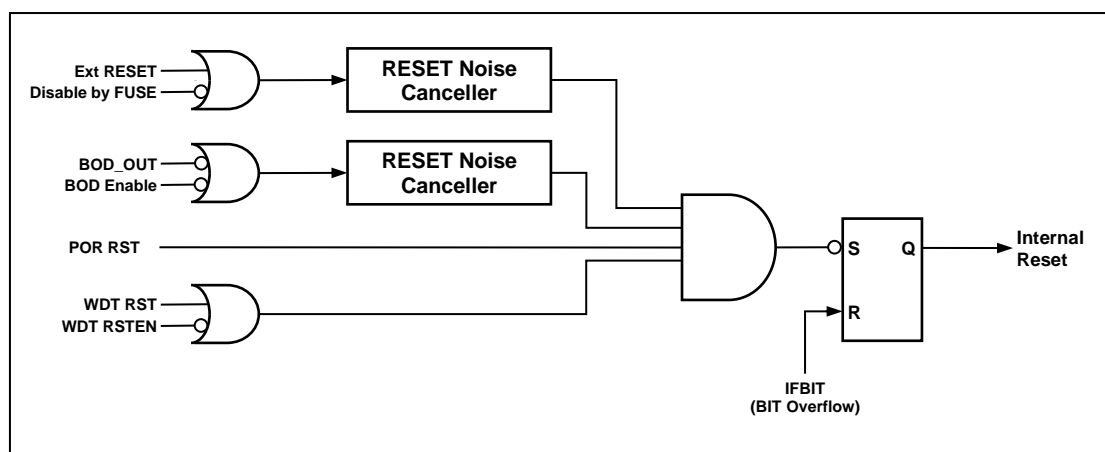

**Figure 13.1 RESET Block Diagram**

### 13.4 RESET Noise Canceller

The Figure 13.2 is the Noise canceller diagram for Noise cancel of RESET. It has the Noise cancel value of about 7us (@V<sub>DD</sub>=5V) to the low input of System Reset.

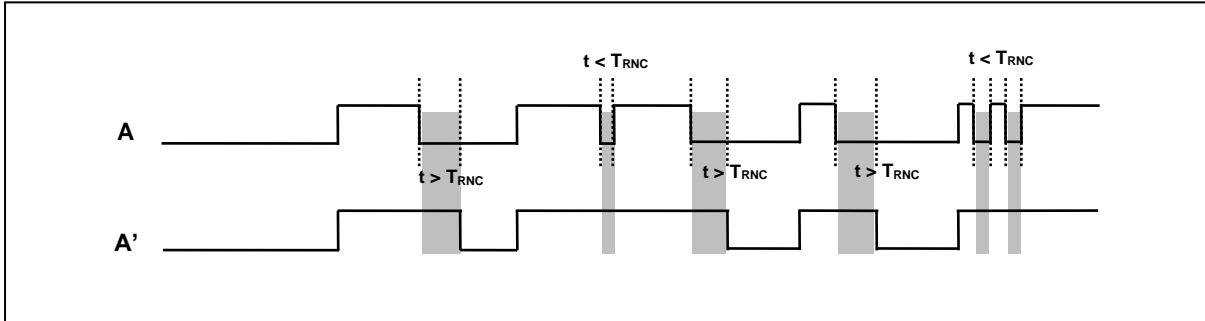

Figure 13.2 Reset noise canceller time diagram

### 13.5 Power ON RESET

When rising device power, the POR (Power ON Reset) have a function to reset the device. If using POR, it executes the device RESET function instead of the RESET IC or the RESET circuits.

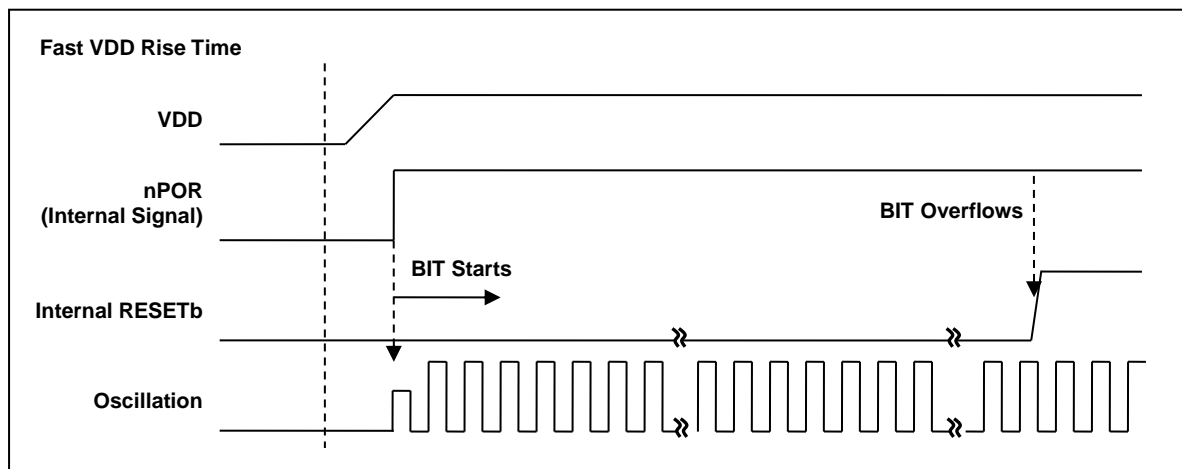

Figure 13.3 Fast VDD rising time

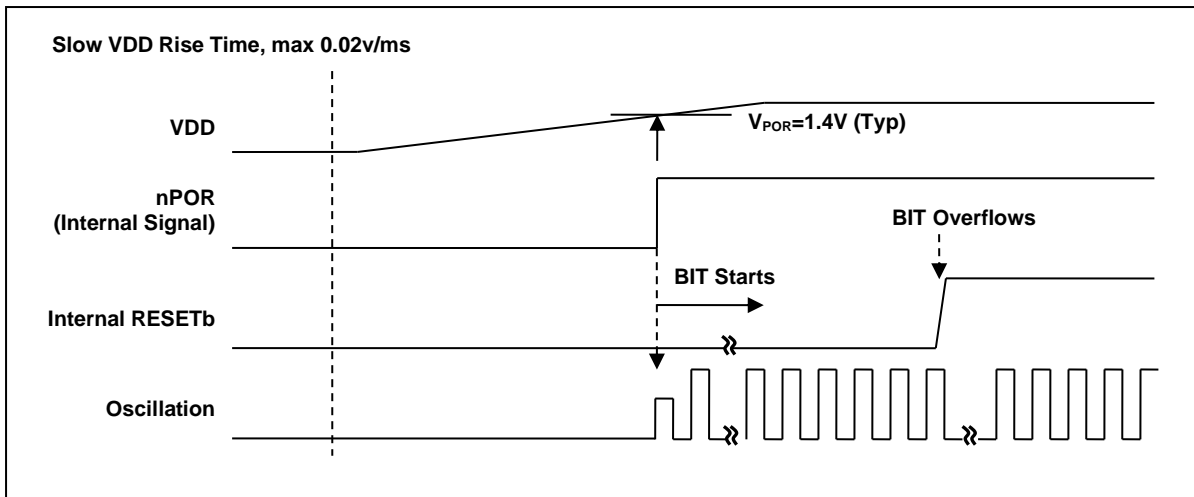

Figure 13.4 Internal RESET Release Timing On Power-Up

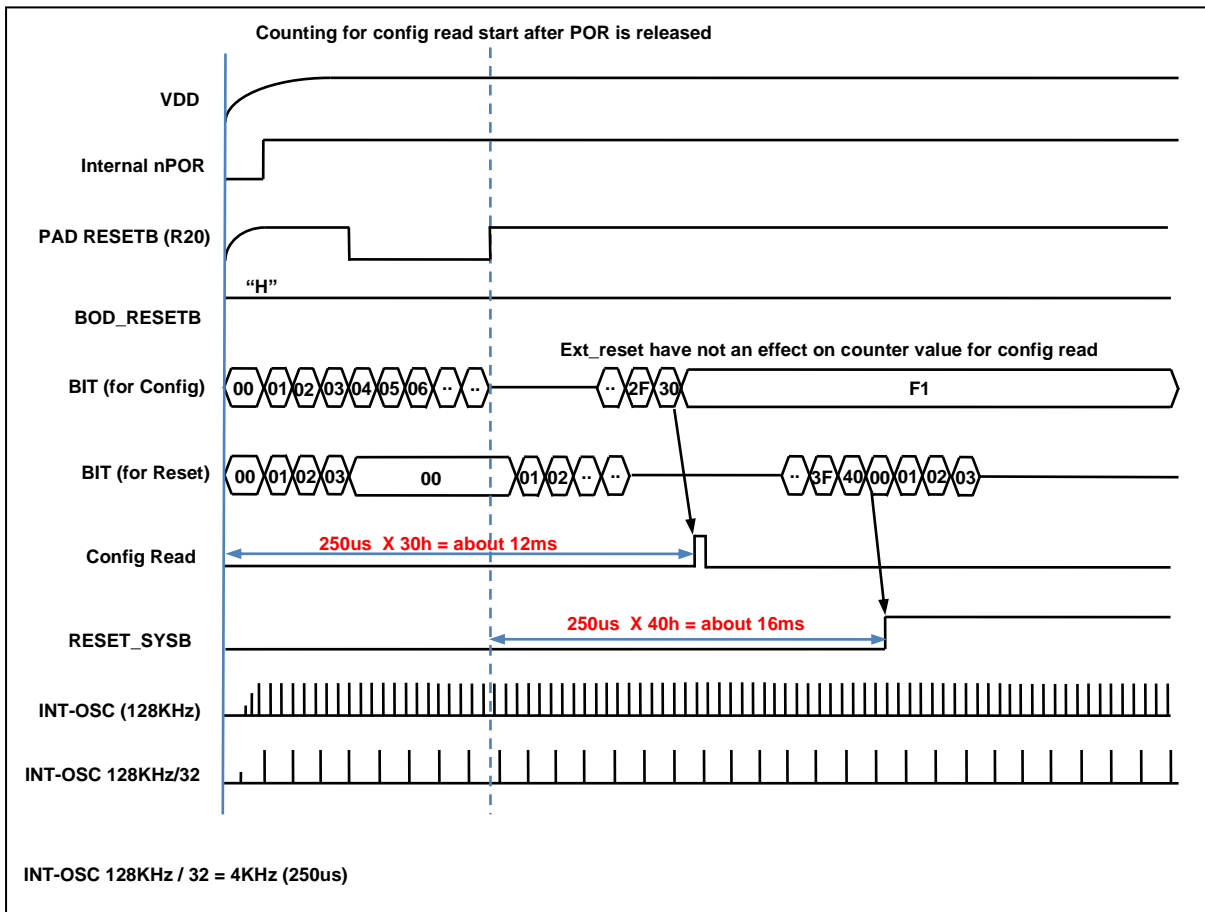

Figure 13.5 Configuration timing when Power-on



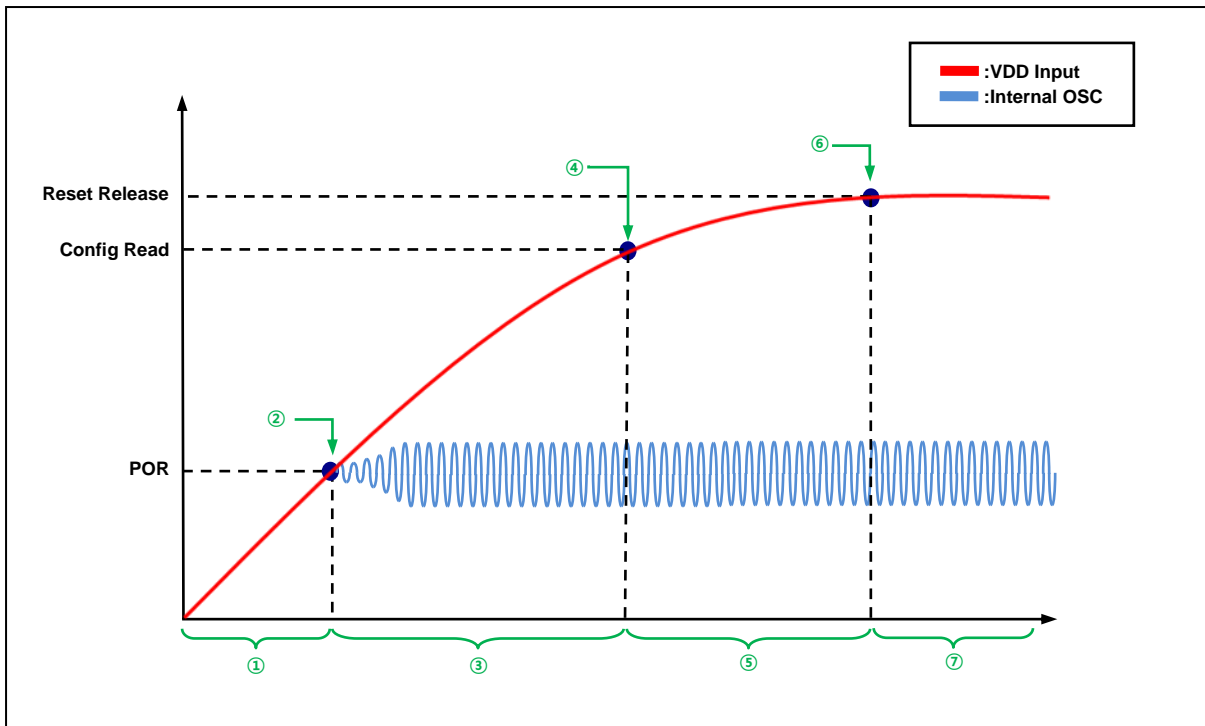

Figure 13.6 Boot Process Wave Form

Table 13-2 Boot Process Description

Process	Description	Remarks
①	-No Operation	
②	-1st POR level Detection -Internal OSC (125KHz) ON	-about 1.4V ~ 1.5V
③	- (INT-OSC125KHz/32)×30h Delay section (=12ms) -VDD input voltage must rise over than flash operating voltage for Config read	-Slew Rate $\geq 0.025V/ms$
④	- Config read point	-about 1.5V ~ 1.6V -Config Value is determined by Writing Option
⑤	- Rising section to Reset Release Level	-16ms point after POR or Ext_reset release
⑥	- Reset Release section (BIT overflow) i) after16ms, after External Reset Release (External reset) ii) 16ms point after POR (POR only)	- BIT is used for Peripheral stability
⑦	-Normal operation	

### 13.6 External RESETB Input

The External RESETB is the input to a Schmitt trigger. A reset is accomplished by holding the reset pin low for at least 7us over, within the operating voltage range and oscillation stable, it is applied, and the internal state is initialized. After reset state becomes '1', it needs the stabilization time with 16ms and after the stable state, the internal RESET becomes '1'. The Reset process step needs 5 oscillator clocks. And the program execution starts at the vector address stored at address 0000H.

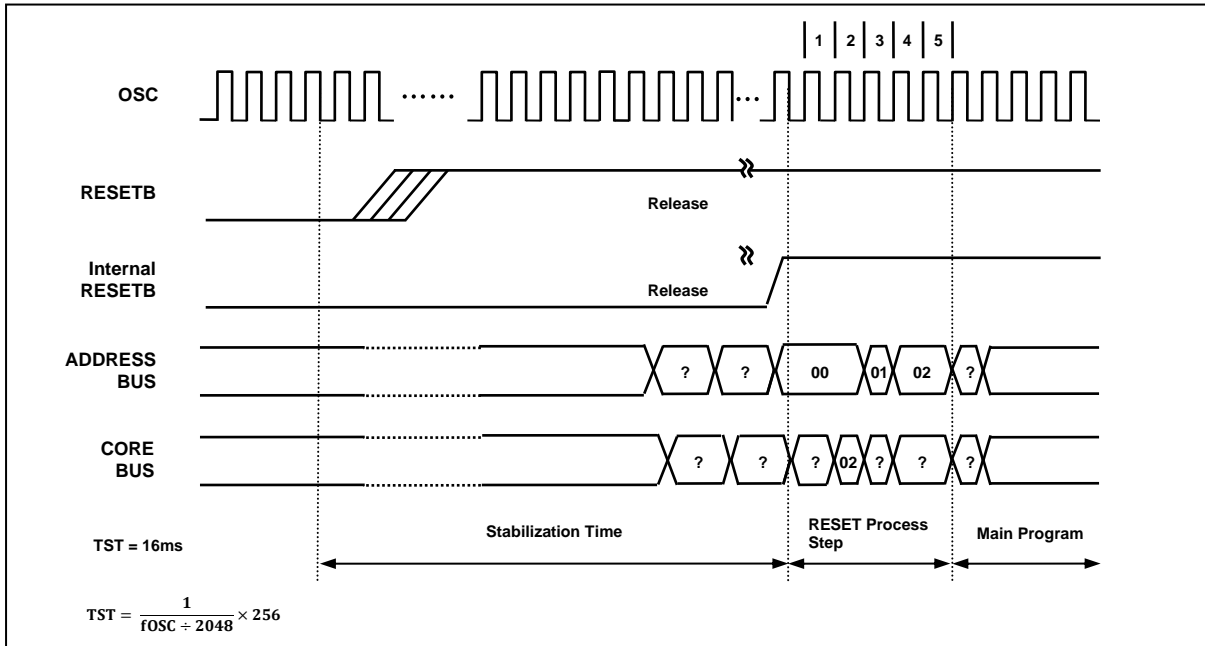

Figure 13.7 Timing Diagram after RESET

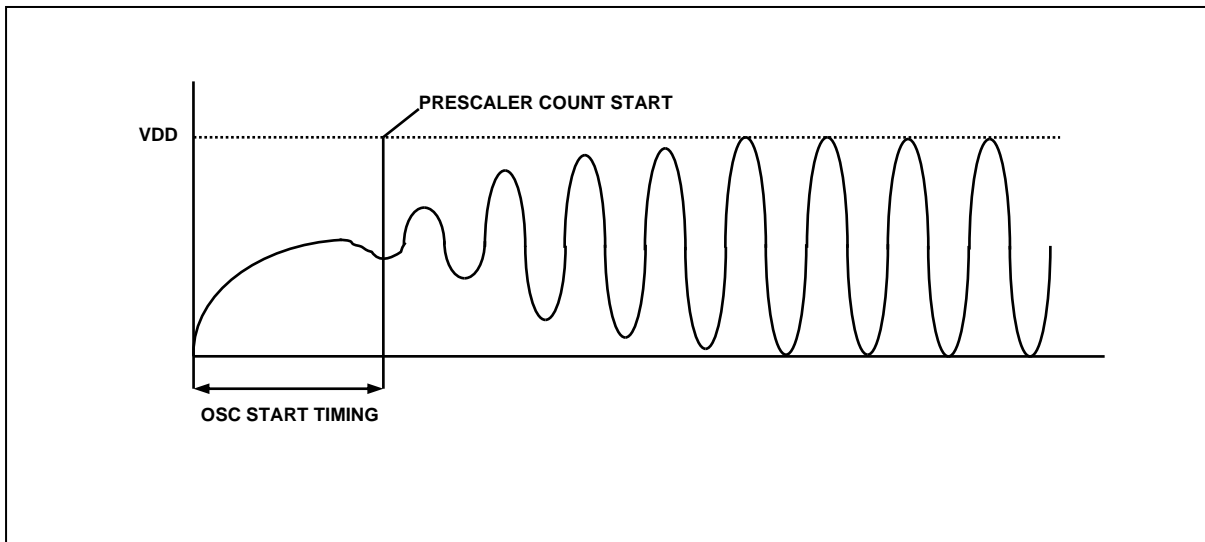

Figure 13.8 Oscillator generating waveform example

Note) as shown Figure 13.8, the stable generating time is not included in the start-up time.

### 13.7 Brown Out Detector Processor

The MC95FG0128A has an On-chip Brown-out detection circuit for monitoring the VDD level during operation by comparing it to a fixed trigger level. The trigger level for the BOD can be selected by BODLS[1:0] bit to be 1.6V, 2.5V, 3.6V or 4.2V. In the STOP mode, this will contribute significantly to the total current consumption. So to minimize the current consumption, the BODEN bit is set to off by software.

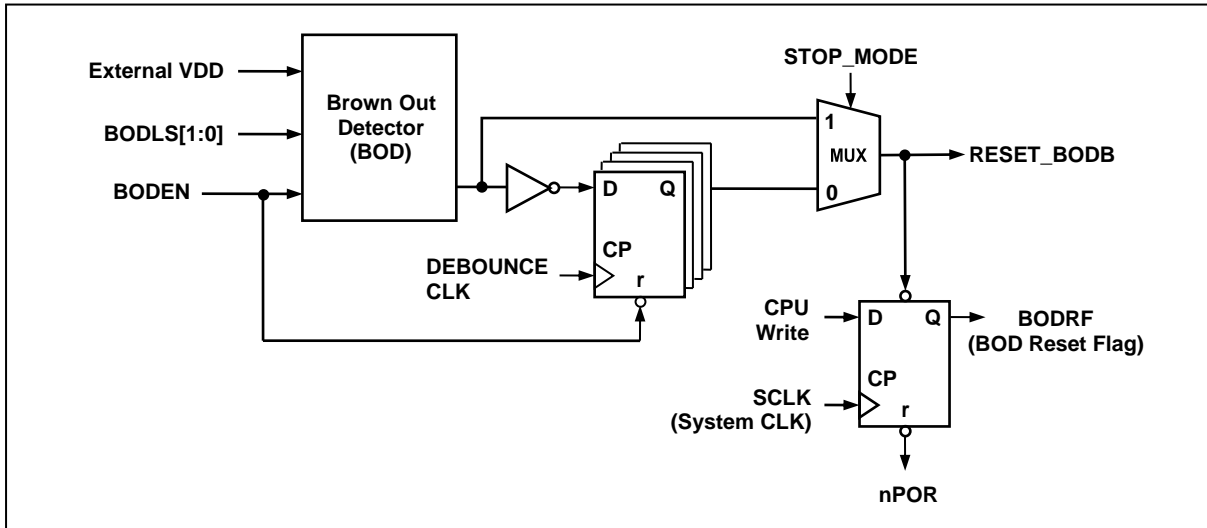

Figure 13.9 Block Diagram of BOD

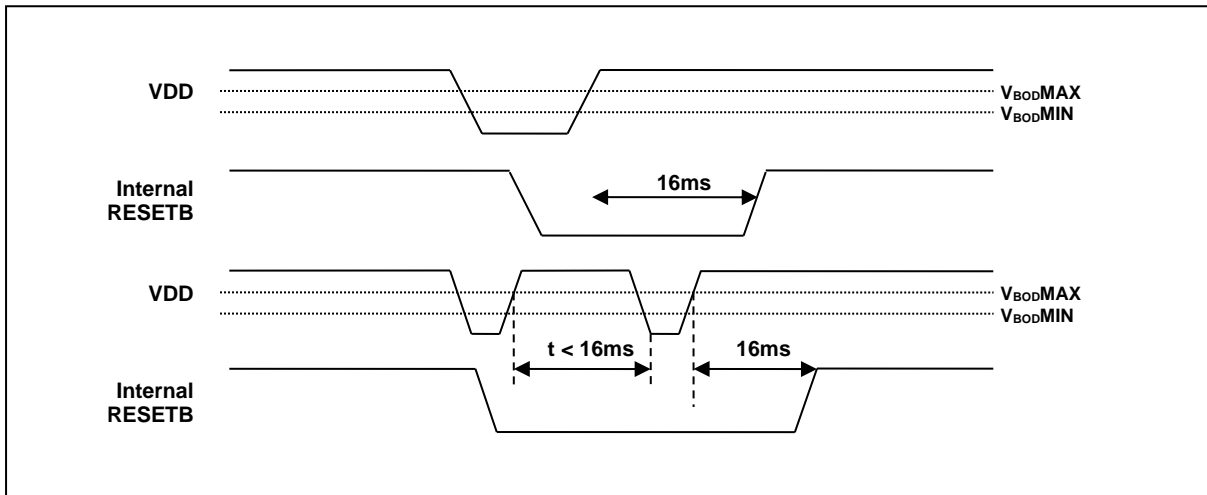

Figure 13.10 Internal Reset at the power fail situation

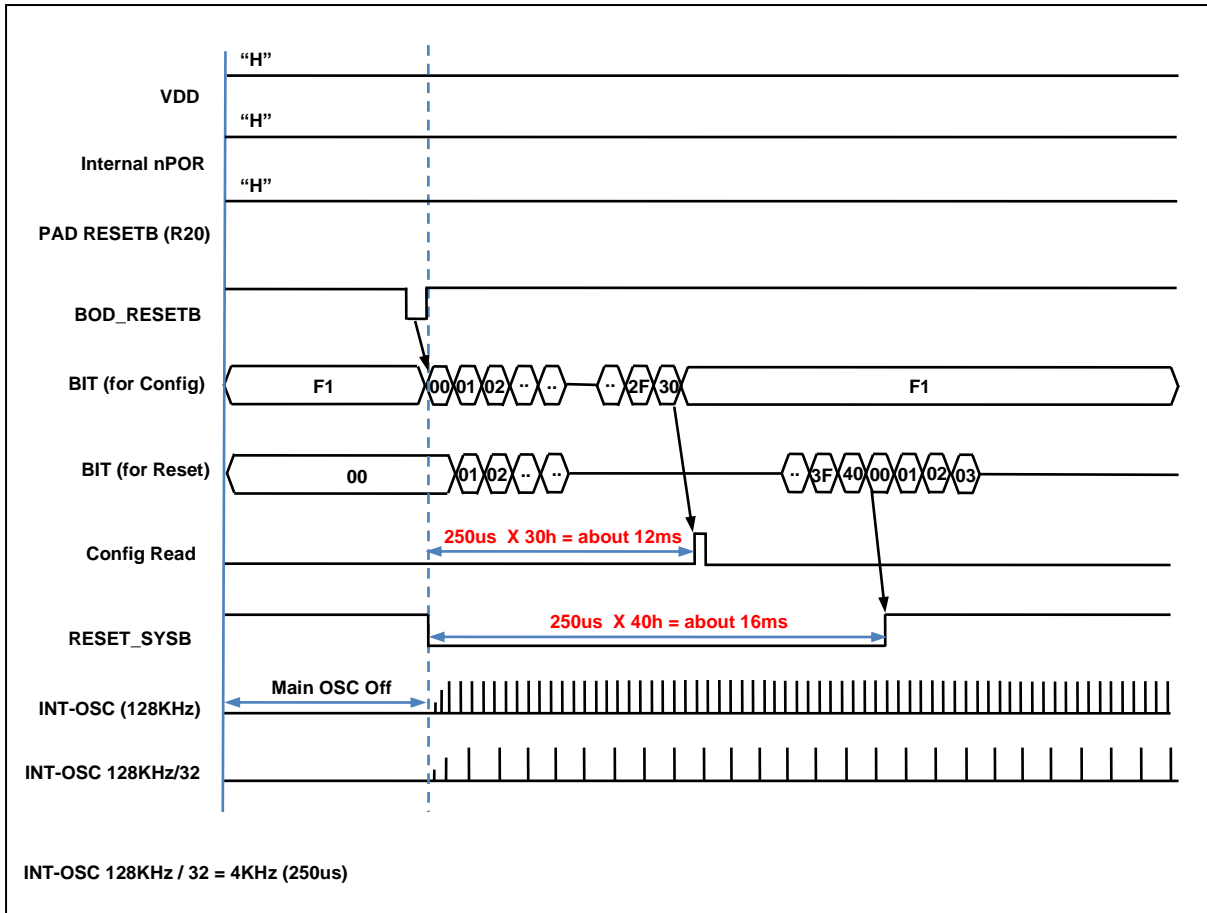

Figure 13.11 Configuration timing when BOD RESET

### 13.7.1 Register Map

Table 13-3 Register Map

Name	Address	Dir	Default	Description
BODR	86H	R/W	81H	BOD Control Register

### 13.7.2 Reset Operation Register description

Reset control Register consists of the BOD Control Register (BODR).

### 13.7.3 Register description for Reset Operation

#### BODR (BOD Control Register) : 86H

7	6	5	4	3	2	1	0
PORF	EXTRF	WDTRF	OCDRF	BODRF	BODLS[1]	BODLS[0]	BODEN
RW	RW	RW	RW	RW	RW	RW	RW

Initial value : 81H

<b>PORF</b>	Power-On Reset flag bit. The bit is reset by writing '0' to this bit.		
	0	No detection	
	1	Detection	
<b>EXTRF</b>	External Reset flag bit. The bit is reset by writing '0' to this bit or by Power ON reset.		
	0	No detection	
	1	Detection	
<b>WDTRF</b>	Watch Dog Reset flag bit. The bit is reset by writing '0' to this bit or by Power ON reset.		
	0	No detection	
	1	Detection	
<b>OCDRF</b>	On-Chip Debug Reset flag bit. The bit is reset by writing '0' to this bit or by Power ON reset.		
	0	No detection	
	1	Detection	
<b>BODRF</b>	Brown-Out Reset flag bit. The bit is reset by writing '0' to this bit or by Power ON reset.		
	0	No detection	
	1	Detection	
<b>BODLS[1:0]</b>	BOD level Voltage		
	BODLS1	BODLS0	Description
	0	0	1.6V
	0	1	2.5V
	1	0	3.6V
	1	1	4.2V
<b>BODEN</b>	BOD operation		
	0	BOD disable	
	1	BOD enable	

## 14. On-chip Debug System

### 14.1 Overview

#### 14.1.1 Description

On-chip debug System (OCD) of MC95FG0128A can be used for programming the non-volatile memories and on-chip debugging. Detailed descriptions for programming via the OCD interface can be found in the following chapter.

Figure 14.1 shows a block diagram of the OCD interface and the On-chip Debug system.

#### 14.1.2 Feature

- Two-wire external interface: 1-wire serial clock input, 1-wire bi-directional serial data bus
- Debugger Access to:
  - All Internal Peripheral Units
  - Internal data RAM
  - Program Counter
  - Flash and Data EEPROM Memories
- Extensive On-chip Debug Support for Break Conditions, Including
  - Break Instruction
  - Single Step Break
  - Program Memory Break Points on Single Address
  - Programming of Flash, EEPROM, Fuses, and Lock Bits through the two-wire Interface
  - On-chip Debugging Supported by Dr.Choice®
- Operating frequency
  - Supports the maximum frequency of the target MCU

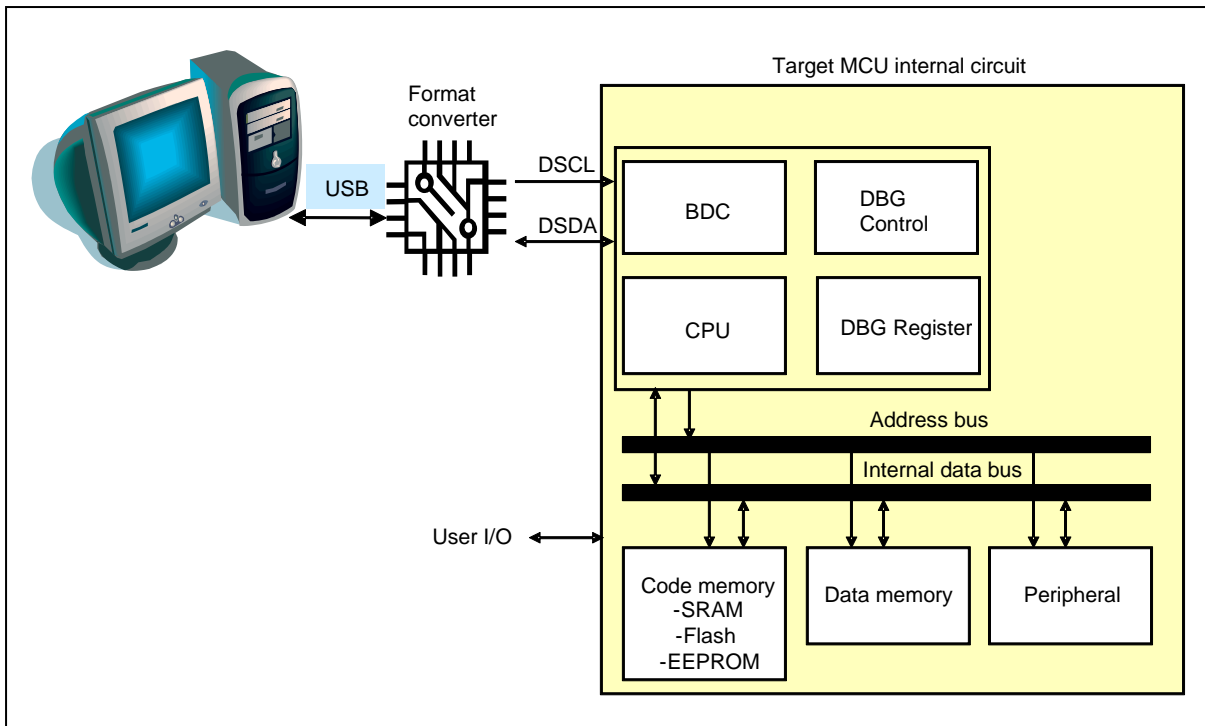

Figure 14.1 Block Diagram of On-chip Debug System

## 14.2 Two-pin external interface

### 14.2.1 Basic transmission packet

- 10-bit packet transmission using two-pin interface.
- 1-packet consists of 8-bit data, 1-bit parity and 1-bit acknowledge.
- Parity is even of '1' for 8-bit data in transmitter.
- Receiver generates acknowledge bit as '0' when transmission for 8-bit data and its parity has no error.
- When transmitter has no acknowledge (Acknowledge bit is '1' at tenth clock), error process is executed in transmitter.
- When acknowledge error is generated, host PC makes stop condition and transmits command which has error again.
- Background debugger command is composed of a bundle of packet.
- Star condition and stop condition notify the start and the stop of background debugger command respectively.

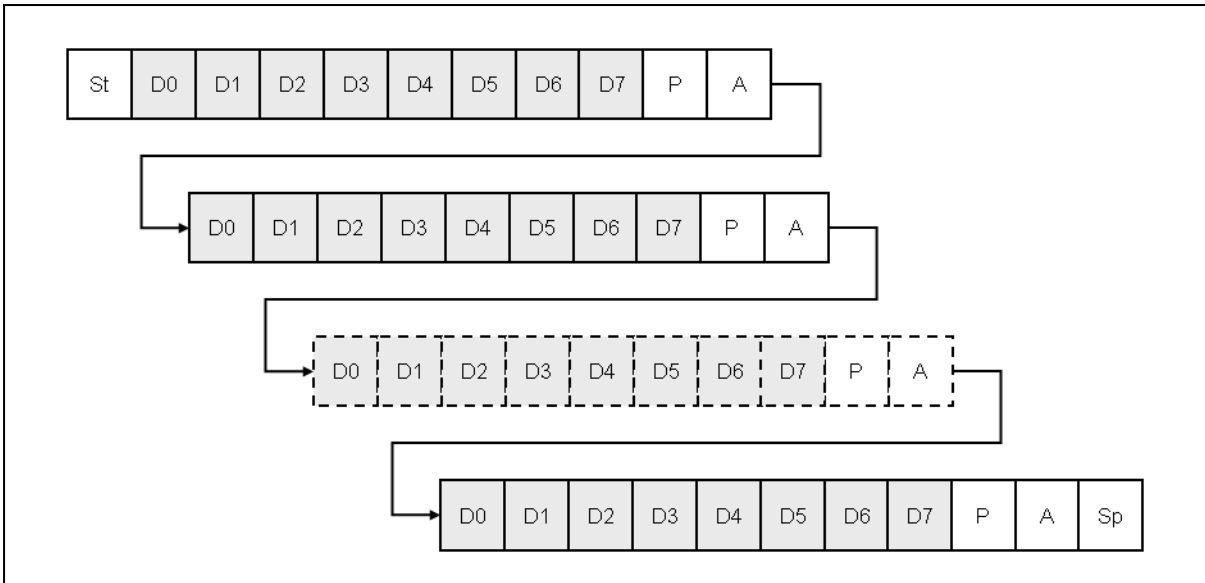

Figure 14.2 10-bit transmission packet

### 14.2.2 Packet transmission timing

#### 14.2.2.1 Data transfer

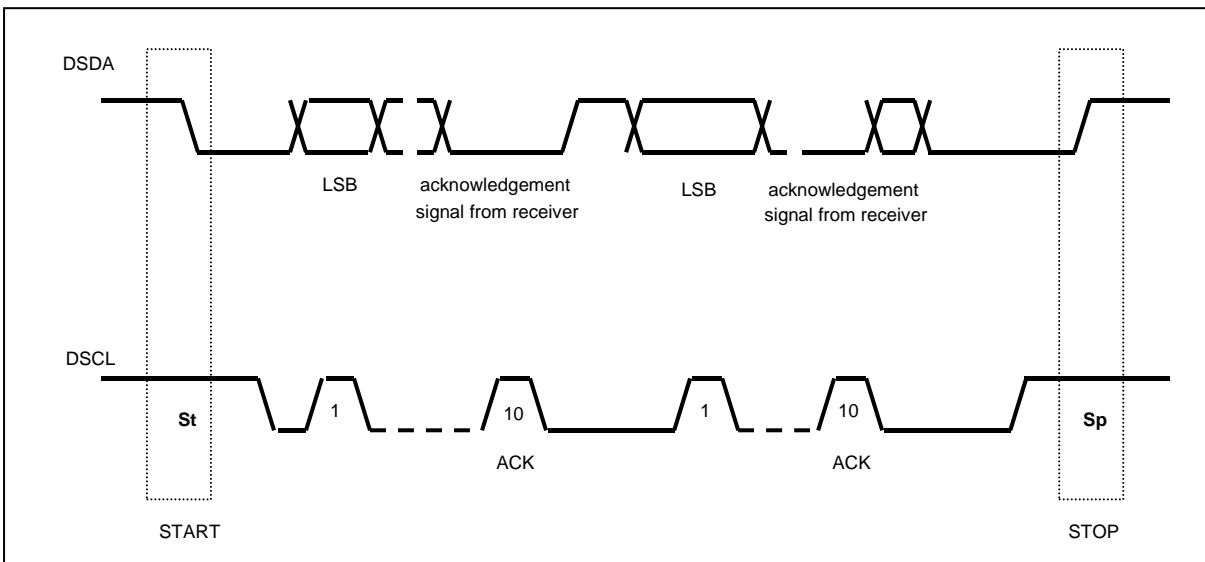

Figure 14.3 Data transfer on the twin bus



14.2.2.2 Bit transfer

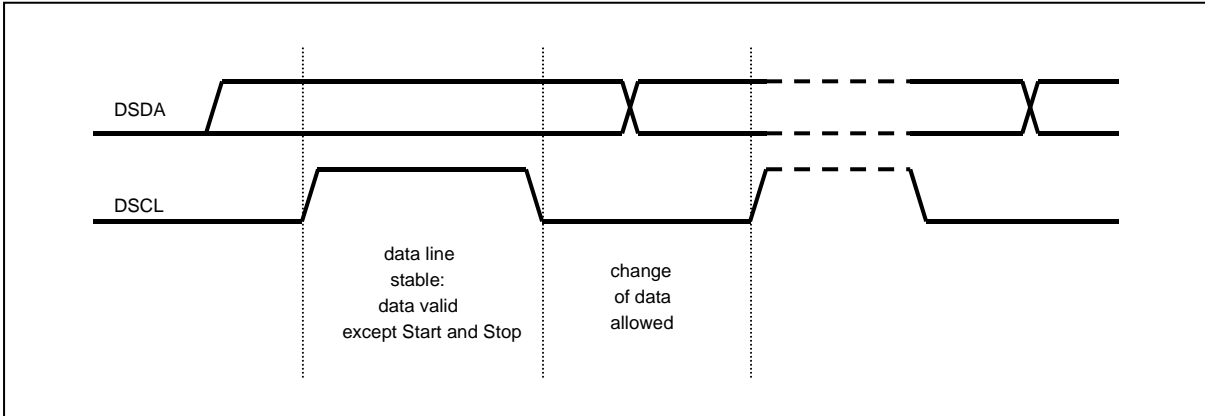

Figure 14.4 Bit transfer on the serial bus

14.2.2.3 Start and stop condition

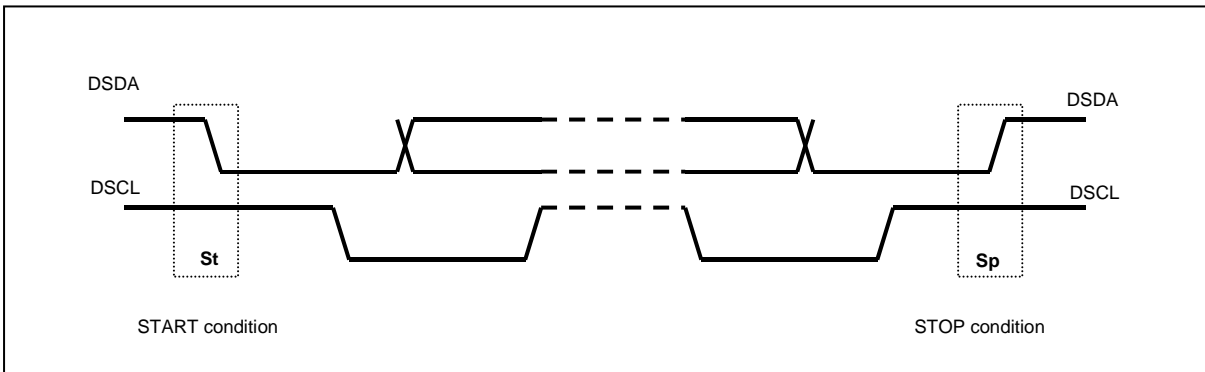

Figure 14.5 Start and stop condition

14.2.2.4 Acknowledge bit

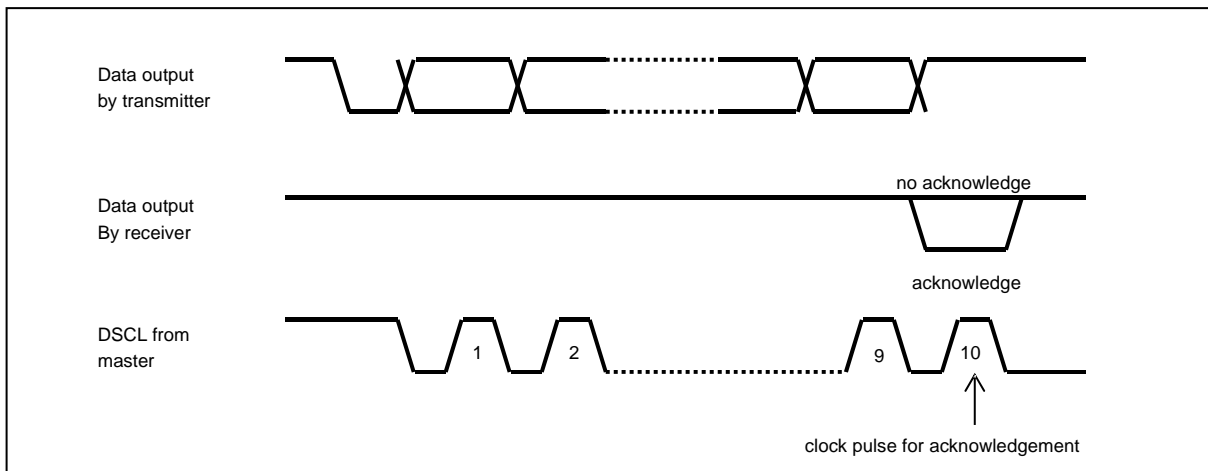

Figure 14.6 Acknowledge on the serial bus

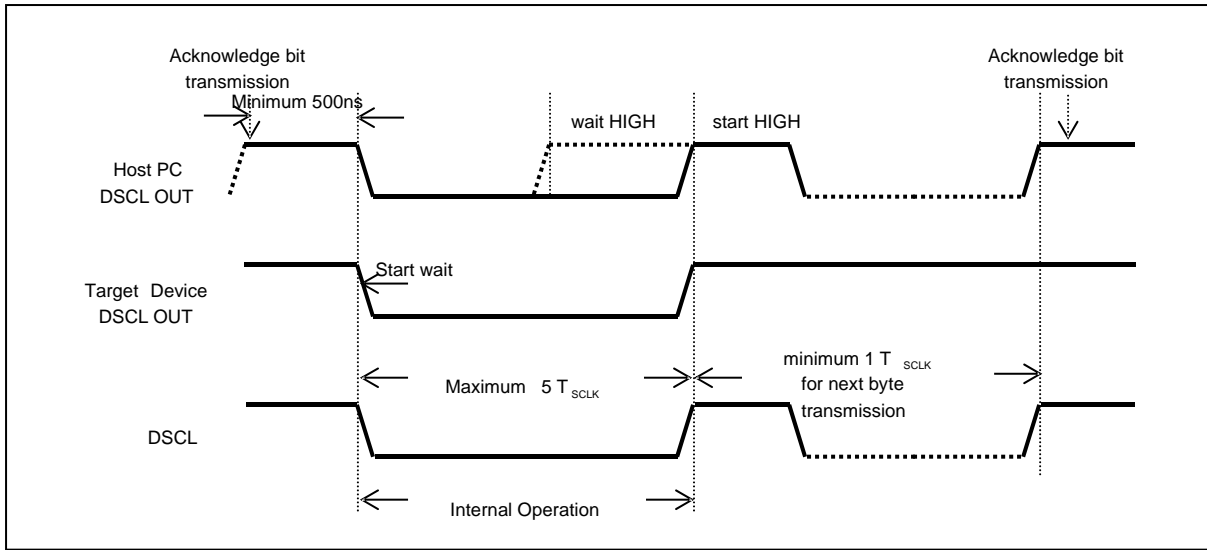

Figure 14.7 Clock synchronization during wait procedure

### 14.2.3 Connection of transmission

Two-pin interface connection uses open-drain (wire-AND bidirectional I/O).

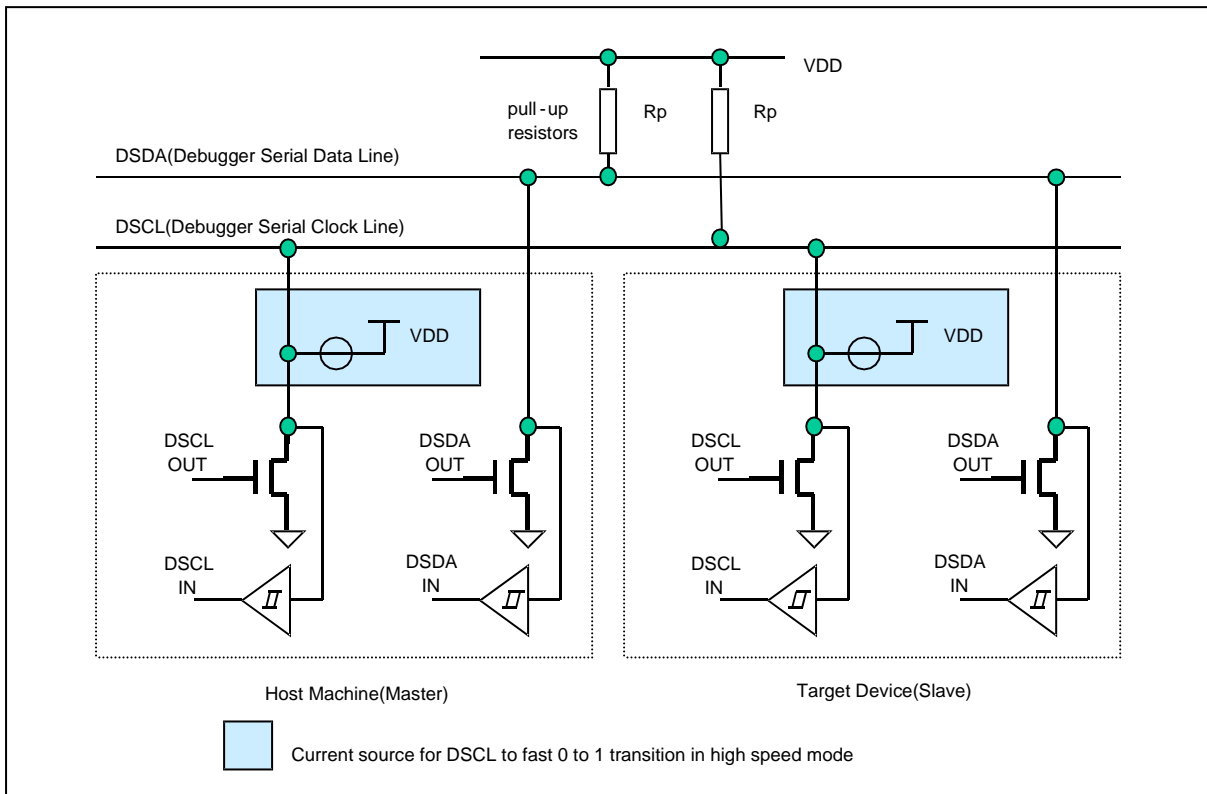

Figure 14.8 Connection of transmission

## 15. Memory Programming

### 15.1 Overview

#### 15.1.1 Description

MC95FG0128A incorporates flash and data EEPROM memory to which a program can be written, erased, and overwritten while mounted on the board. Also, data EEPROM can be programmed or erased in user program.

Serial ISP modes and byte-parallel ROM writer mode are supported.

#### 15.1.2 Features

- Flash Size : 128Kbytes
- Single power supply program and erase
- Command interface for fast program and erase operation
- Up to 10,000 program/erase cycles at typical voltage and temperature for flash memory
- Up to 100,000 program/erase cycles at typical voltage and temperature for data EEPROM memory
- Security feature

### 15.2 Flash and EEPROM Control and status register

Registers to control Flash and Data EEPROM are Mode Register (FEMR), Control Register (FECR), Status Register (FESR), Time Control Register (FETCR), Address Low Register (FEARL), Address Middle Register (FEARM), address High Register (FEARH) and Data Register (FEDR). They are mapped to SFR area and can be accessed only in programming mode.

#### 15.2.1 Register Map

Table 15-1 Register Map

Name	Address	Dir	Default	Description
FEMR	EAH	R/W	00H	Flash and EEPROM Mode Register
FECR	EBH	R/W	03H	Flash and EEPROM Control Register
FESR	ECH	R/W	80H	Flash and EEPROM Status Register
FETCR	EDH	R/W	00H	Flash and EEPROM Time Control Register
FEARL	F2H	R/W	00H	Flash and EEPROM Address Low Register
FEARM	F3H	R/W	00H	Flash and EEPROM Address Middle Register
FEARH	F4H	R/W	00H	Flash and EEPROM Address High Register
FEDR	F5H	R/W	00H	Flash and EEPROM Data Register

## 15.2.2 Register description for Flash and EEPROM

### FEMR (Flash and EEPROM Mode Register) : EAH

7	6	5	4	3	2	1	0
FSEL	ESEL	PGM	ERASE	PBUFF	OTPE	VFY	FEEN
RW	RW	RW	RW	RW	RW	RW	RW

Initial value : 00H

<b>FSEL</b>	Select flash memory. 0 Deselect flash memory 1 Select flash memory
<b>ESEL</b>	Select data EEPROM 0 Deselect data EEPROM 1 Select data EEPROM
<b>PGM</b>	Enable program or program verify mode with VFY 0 Disable program or program verify mode 1 Enable program or program verify mode
<b>ERASE</b>	Enable erase or erase verify mode with VFY 0 Disable erase or erase verify mode 1 Enable erase or erase verify mode
<b>PBUFF</b>	Select page buffer 0 Deselect page buffer 1 Select page buffer
<b>OTPE</b>	Select OTP area instead of program memory 0 Deselect OTP area 1 Select OTP area
<b>VFY</b>	Set program or erase verify mode with PGM or ERASE Program Verify: PGM=1, VFY=1 Erase Verify: ERASE=1, VFY=1
<b>FEEN</b>	Enable program and erase of Flash and data EEPROM. When inactive, it is possible to read as normal mode 0 Disable program and erase 1 Enable program and erase

### FECR (Flash and EEPROM Control Register) : EBH

7	6	5	4	3	2	1	0
AEF	AEE	EXIT1	EXIT0	WRITE	READ	nFERST	nPBRST
RW	RW	RW	RW	RW	RW	RW	RW

Initial value : 03H

<b>AEF</b>	Enable flash bulk erase mode 0 Disable bulk erase mode of Flash memory 1 Enable bulk erase mode of Flash memory
<b>AEE</b>	Enable data EEPROM bulk erase mode 0 Disable bulk erase mode of data EEPROM 1 Enable bulk erase mode of data EEPROM
<b>EXIT[1:0]</b>	Exit from program mode. It is cleared automatically after 1 clock EXIT1      EXIT0      Description

	0	0	Don't exit from program mode
	0	1	Don't exit from program mode
	1	0	Don't exit from program mode
	1	1	Exit from program mode
<b>WRITE</b>	Start to program or erase of Flash and data EEPROM. It is cleared automatically after 1 clock		
	0	No operation	
	1	Start to program or erase of Flash and data EEPROM	
<b>READ</b>	Start auto-verify of Flash or data EEPROM. It is cleared automatically after 1 clock		
	0	No operation	
	1	Start auto-verify of Flash or data EEPROM	
<b>nFERST</b>	Reset Flash or data EEPROM control logic. It is cleared automatically after 1 clock		
	0	No operation	
	1	Reset Flash or data EEPROM control logic.	
<b>nPBRST</b>	Reset page buffer with PBUFF. It is cleared automatically after 1 clock		
	PBUFF	nPBRST	Description
	0	0	Page buffer reset
	1	0	Write checksum reset

WRITE and READ bits can be used in program, erase and verify mode with FEAR registers. Read or writes for memory cell or page buffer uses read and write enable signals from memory controller. Indirect address mode with FEAR is only allowed to program, erase and verify

**FESR (Flash and EEPROM Status Register) : ECH**

<b>7</b>	<b>6</b>	<b>5</b>	<b>4</b>	<b>3</b>	<b>2</b>	<b>1</b>	<b>0</b>
PEVBSY	VFYGOOD	-	-	ROMINT	WMODE	EMODE	VMODE
R	R/W	R	R	R/W	R	R	R

Initial value : 80H

<b>PEVBSY</b>	Operation status flag. It is cleared automatically when operation starts. Operations are program, erase or verification
	0 Busy (Operation processing)
	1 Complete Operation
<b>VFYGOOD</b>	Auto-verification result flag.
	0 Auto-verification fails
	1 Auto-verification successes
<b>ROMINT</b>	Flash and Data EEPROM interrupt request flag. Auto-cleared when program/erase/verify starts. Active in program/erase/verify completion
	0 No interrupt request.
	1 Interrupt request.
<b>WMODE</b>	Write mode flag
<b>EMODE</b>	Erase mode flag
<b>VMODE</b>	Verify mode flag

**FEARL (Flash and EEPROM address low Register) : F2H**

7	6	5	4	3	2	1	0
ARL7	ARL6	ARL5	ARL4	ARL3	ARL2	ARL1	ARL0
W	W	W	W	W	W	W	W

Initial value : 00H

**ARL[7:0]** Flash and EEPROM address low**FEARM (Flash and EEPROM address middle Register) : F3H**

7	6	5	4	3	2	1	0
ARM7	ARM6	ARM5	ARM4	ARM3	ARM2	ARM1	ARM0
W	W	W	W	W	W	W	W

Initial value : 00H

**ARM[7:0]** Flash and EEPROM address middle**FEARH (Flash and EEPROM address high Register) : F4H**

7	6	5	4	3	2	1	0
ARH7	ARH6	ARH5	ARH4	ARH3	ARH2	ARH1	ARH0
W	W	W	W	W	W	W	W

Initial value : 00H

**ARH[7:0]** Flash and EEPROM address high

FEAR registers are used for program, erase and auto-verify. In program and erase mode, it is page address and ignored the same least significant bits as the number of bits of page address. In auto-verify mode, address increases automatically by one.

FEARs are write-only register. Reading these registers returns 24-bit checksum result

**FEDR (Flash and EEPROM data control Register) : F5H**

7	6	5	4	3	2	1	0
FEDR7	FEDR6	FEDR5	FEDR4	FEDR3	FEDR2	FEDR1	FEDR0
W	W	W	W	W	W	W	W

Initial value : 00H

**FEDR[7:0]** Flash and EEPROM data

Data register. In no program/erase/verify mode, READ/WRITE of FECE read or write data from EEPROM or FLASH to this register or from this register to Flash or EEPROM.

The sequence of writing data to this register is used for EEPROM program entry. The mode entrance sequence is to write 0xA5 and 0x5A to it in order.

**FETCR (Flash and EEPROM Time control Register) : EDH**

7	6	5	4	3	2	1	0
TCR7	TCR6	TCR5	TCR4	TCR3	TCR2	TCR1	TCR0
RW	RW	RW	RW	RW	RW	RW	RW

Initial value : 00H

**TCR[7:0]** Flash and EEPROM Time control

Program and erase time is controlled by setting FETCR register. Program and erase timer uses 10-bit counter. It increases by one at each divided system clock frequency(=SCLK/128). It is cleared when program or erase starts. Timer stops when 10-bit counter is same to FETCR. PEVBSY is cleared when program, erase or verify starts and set when program, erase or verify stops.

Max program/erase time at 20Mhz system clock :  $(255+1) * 2 * (0.05\mu s * 128) = 3.2768ms$

In the case of 10% of error rate of counter source clock, program or erase time is 3.0~3.5ms

\* Program/erase time calculation

for page write or erase,  $T_{pe} = (TCON+1) * 2 * (SCLK * 128)$

for bulk erase,  $T_{be} = (TCON+1) * 4 * (SCLK * 128)$

**Table 15-2 Program/erase Time**

※ Recommended program/erase time at 20Mhz (FETCR = C3h)

	Min	Typ	Max	Unit
program/erase Time	2.4	2.5	2.6	ms

### 15.3 Memory map

#### 15.3.1 Flash Memory Map

Program memory uses 128K byte of Flash memory. It is read by byte and written by byte or page. One page is 128-byte

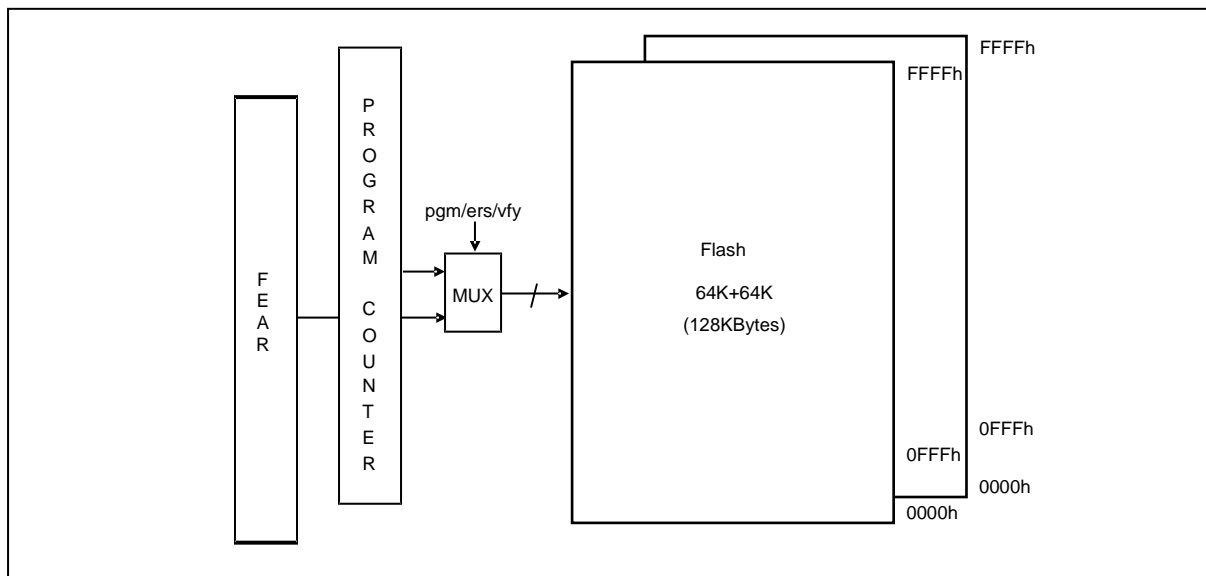

**Figure 15.1 Flash Memory Map**

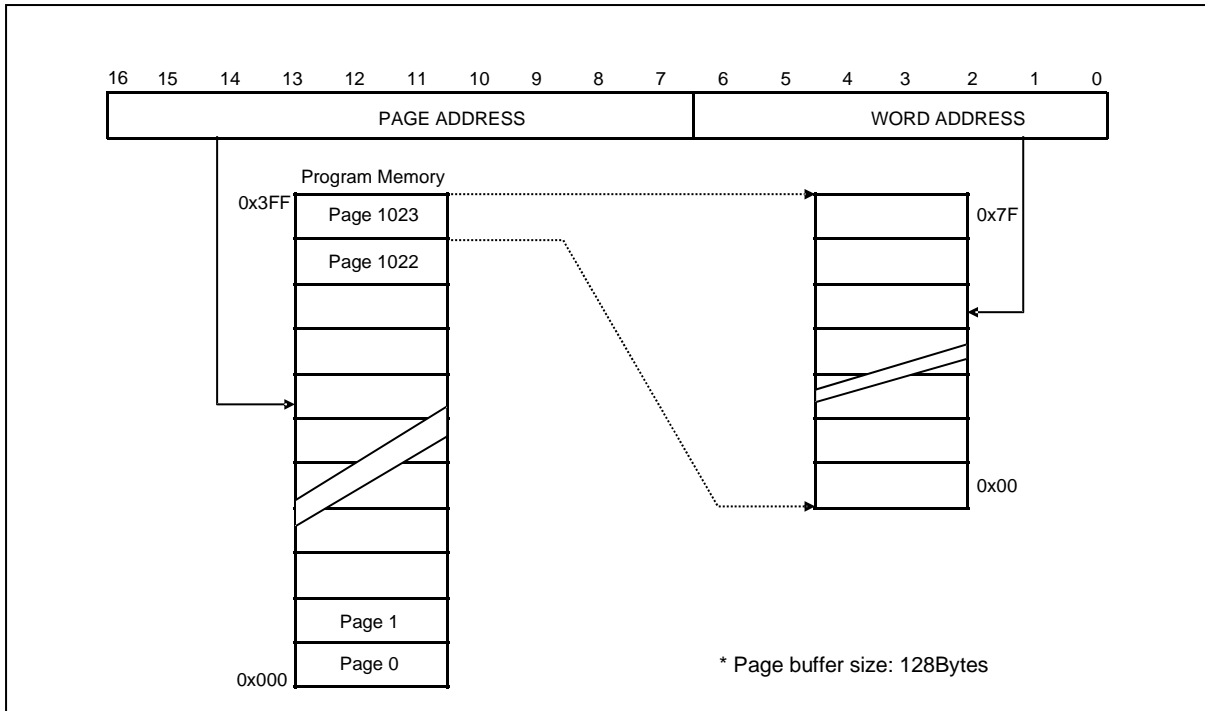

Figure 15.2 Address configuration of Flash memory

15.3.2 Data EEPROM Memory Map

Data EEPROM memory uses 4K byte of EEPROM. It is read by byte and written by byte or page. One page is 16-byte. It is mapped to external data memory of 8051

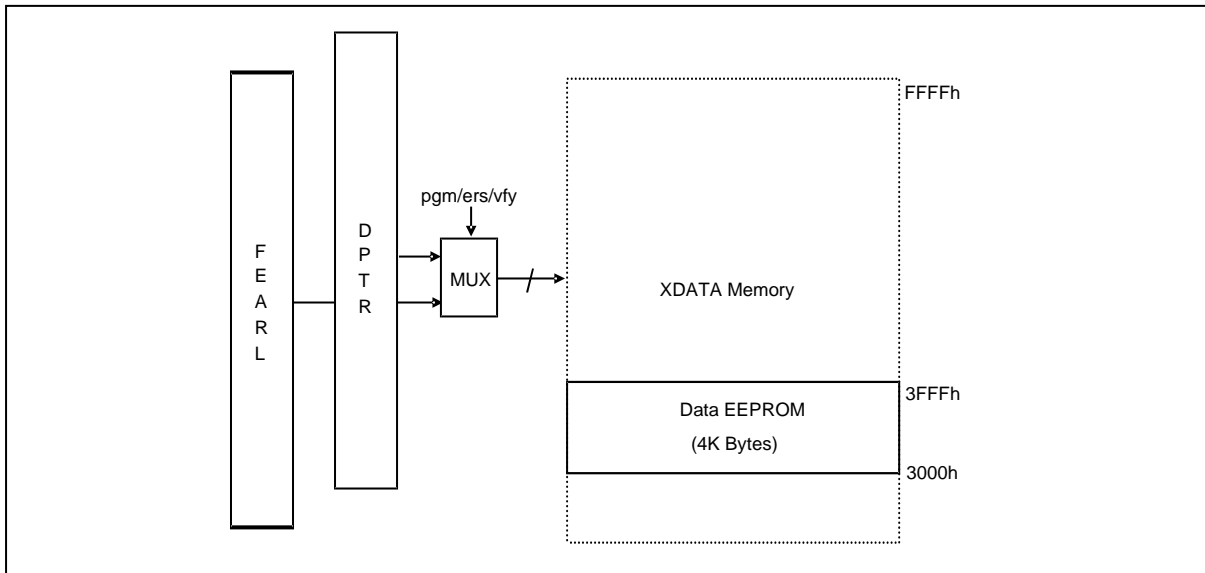

Figure 15.3 Data EEPROM memory map



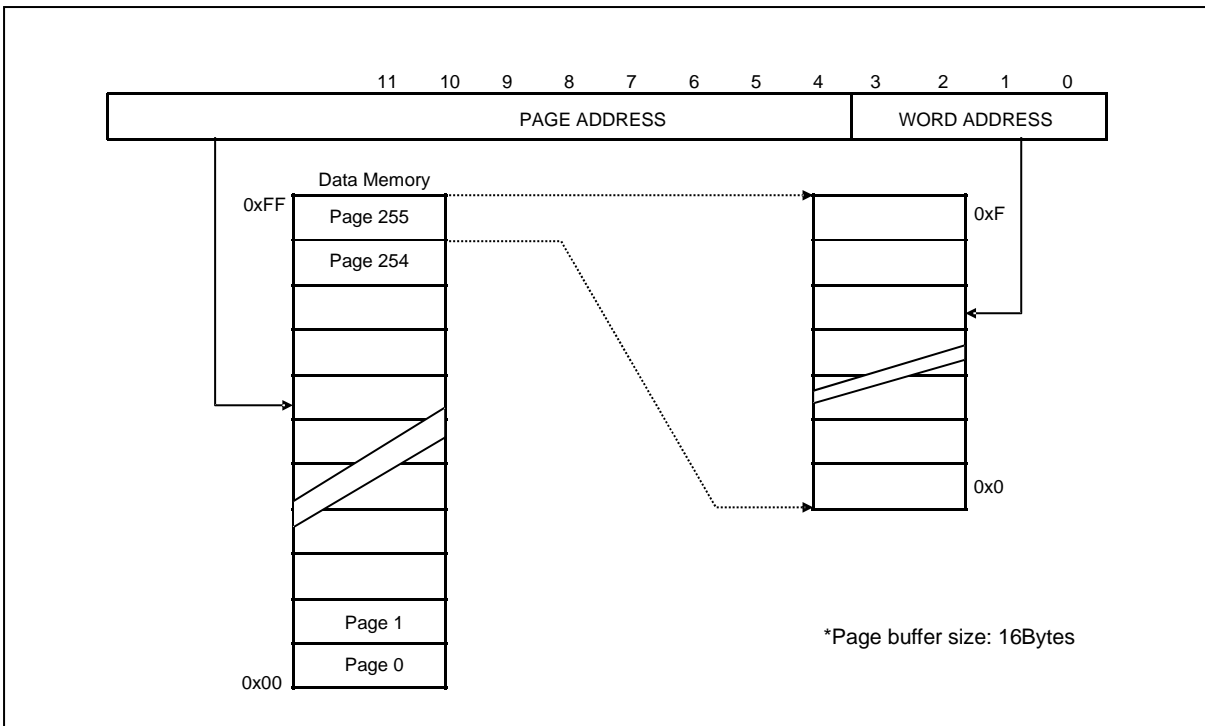

Figure 15.4 Address configuration of data EEPROM

### 15.4 Serial In-System Program Mode

Serial in-system program uses the interface of debugger which uses two wires. Refer to chapter 14 in details about debugger

#### 15.4.1 Flash operation

**Configuration**(This Configuration is just used for follow description)

7	6	5	4	3	2	1	0
-	FEMR[4]&[1]	FEMR[5]&[1]	-	-	FEMR[2]	FECR[6]	FECR[7]
-	ERASE&VFY	PGM&VFY	-	-	OTPE	AEE	AEF

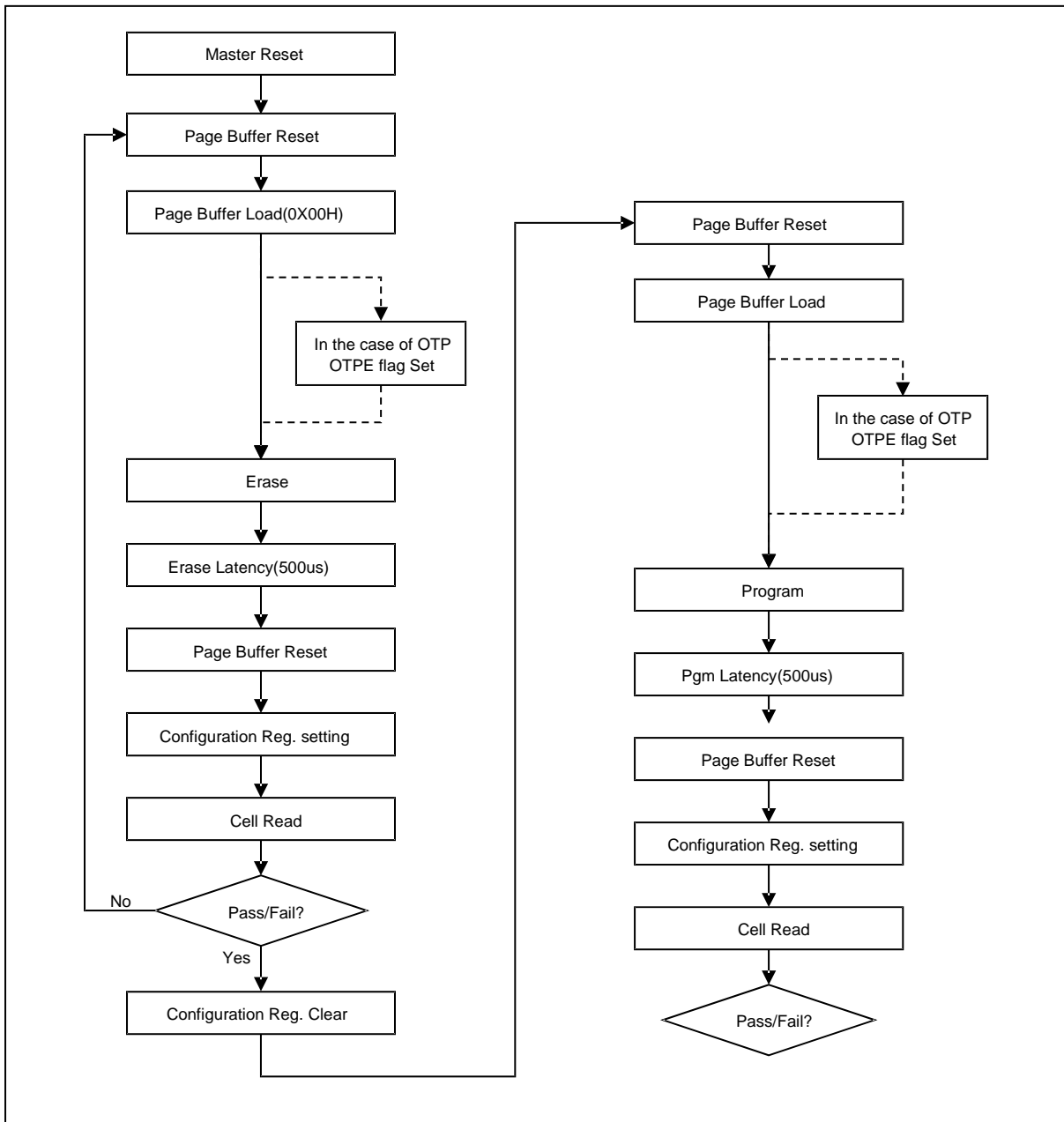

**Figure 15.5 The sequence of page program and erase of Flash memory**

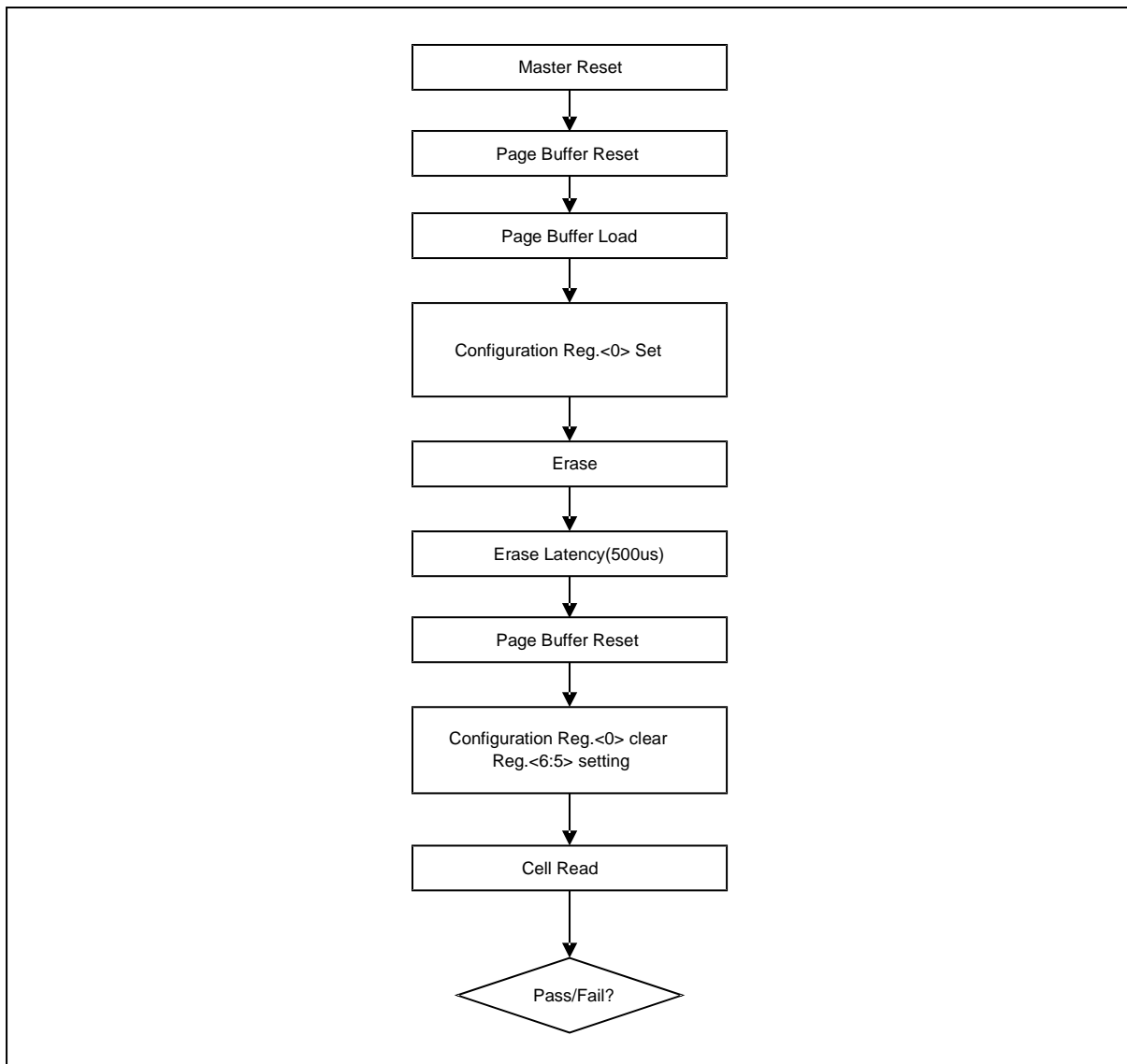

Figure 15.6 The sequence of bulk erase of Flash memory

#### 15.4.1.1 Flash Read

- Step 1. Enter OCD(=ISP) mode.
- Step 2. Set ENBDM bit of BCR.
- Step 3. Enable debug and Request debug mode.
- Step 4. Read data from Flash.

#### 15.4.1.2 Enable program mode

- Step 1. Enter OCD(=ISP) mode.<sup>1</sup>
- Step 2. Set ENBDM bit of BCR.
- Step 3. Enable debug and Request debug mode.
- Step 4. Enter program/erase mode sequence.<sup>2</sup>

- (1) Write 0xAA to 0xF555.
- (2) Write 0x55 to 0xFAAA.
- (3) Write 0xA5 to 0xF555.

<sup>1</sup> Refer to how to enter ISP mode..

<sup>2</sup> Command sequence to activate Flash write/erase mode. It is composed of sequentially writing data of Flash memory.

#### 15.4.1.3 Flash write mode

- Step 1. Enable program mode.
- Step 2. Reset page buffer. FEMR: 1000\_0001 FECR:0000\_0010
- Step 3. Select page buffer. FEMR:1000\_1001
- Step 4. Write data to page buffer.(Address automatically increases by twin.)
- Step 5. Set write mode. FEMR:1010\_0001
- Step 6. Set page address. FEARH:FEARM:FEARL=20'hx\_xxxx
- Step 7. Set FETCR.
- Step 8. Start program. FECR:0000\_1011
- Step 9. Insert one NOP operation
- Step 10. Read FESR until PEVBSY is 1.
- Step 11. Repeat step2 to step 8 until all pages are written.

#### 15.4.1.4 Flash page erase mode

- Step 1. Enable program mode.
- Step 2. Reset page buffer. FEMR: 1000\_0001 FECR:0000\_0010
- Step 3. Select page buffer. FEMR:1000\_1001
- Step 4. Write 'h00 to page buffer. (Data value is not important.)
- Step 5. Set erase mode. FEMR:1001\_0001
- Step 6. Set page address. FEARH:FEARM:FEARL=20'hx\_xxxx
- Step 7. Set FETCR.
- Step 8. Start erase. FECR:0000\_1011
- Step 9. Insert one NOP operation
- Step 10. Read FESR until PEVBSY is 1.
- Step 11. Repeat step2 to step 8 until all pages are erased.

#### 15.4.1.5 Flash bulk erase mode

- Step 1. Enable program mode.
- Step 2. Reset page buffer. FEMR: 1000\_0001 FECR:0000\_0010
- Step 3. Select page buffer. FEMR:1000\_1001
- Step 4. Write 'h00 to page buffer. (Data value is not important.)
- Step 5. Set erase mode. FEMR:1001\_0001.

(Only main cell area is erased. For bulk erase including OTP area, select OTP area.(set FEMR to 1000\_1101.)

- Step 6. Set FETCR
- Step 7. Start bulk erase. FECR:1000\_1011
- Step 8. Insert one NOP operation
- Step 9. Read FESR until PEVBSY is 1.

#### 15.4.1.6 Flash OTP area read mode

- Step 1. Enter OCD(=ISP) mode.
- Step 2. Set ENBDM bit of BCR.
- Step 3. Enable debug and Request debug mode.
- Step 4. Select OTP area. FEMR:1000\_0101
- Step 5. Read data from Flash.

#### 15.4.1.7 Flash OTP area write mode

- Step 1. Enable program mode.
- Step 2. Reset page buffer. FEMR: 1000\_0001 FECR:0000\_0010
- Step 3. Select page buffer. FEMR:1000\_1001
- Step 4. Write data to page buffer.(Address automatically increases by twin.)
- Step 5. Set write mode and select OTP area. FEMR:1010\_0101
- Step 6. Set page address. FEARH:FEARM:FEARL=20'hx\_xxxx
- Step 7. Set FETCR.
- Step 8. Start program. FECR:0000\_1011
- Step 9. Insert one NOP operation
- Step 10. Read FESR until PEVBSY is 1.

#### 15.4.1.8 Flash OTP area erase mode

- Step 1. Enable program mode.
- Step 2. Reset page buffer. FEMR: 1000\_0001 FECR:0000\_0010
- Step 3. Select page buffer. FEMR:1000\_1001
- Step 4. Write 'h00 to page buffer. (Data value is not important.)
- Step 5. Set erase mode and select OTP area. FEMR:1001\_0101
- Step 6. Set page address. FEARH:FEARM:FEARL=20'hx\_xxxx
- Step 7. Set FETCR.
- Step 8. Start erase. FECR:0000\_1011
- Step 9. Insert one NOP operation
- Step 10. Read FESR until PEVBSY is 1.

#### 15.4.1.9 Flash program verify mode

- Step 1. Enable program mode.
- Step 2. Set program verify mode. FEMR:1010\_0011
- Step 3. Read data from Flash.

#### 15.4.1.10 OTP program verify mode

- Step 1. Enable program mode.
- Step 2. Set program verify mode. FEMR:1010\_0111
- Step 3. Read data from Flash.

#### 15.4.1.11 Flash erase verify mode

- Step 1. Enable program mode.
- Step 2. Set erase verify mode. FEMR:1001\_0011
- Step 3. Read data from Flash.

#### 15.4.1.12 Flash page buffer read

- Step 1. Enable program mode.
- Step 2. Select page buffer. FEMR:1000\_1001
- Step 3. Read data from Flash.

### 15.4.2 Data EEPROM operation

Program and erase operation of Data EEPROM are executed by direct and indirect address mode. Direct address mode uses external data area of 8051. Indirect address mode uses address register of SFR area..

#### 15.4.2.1 Data EEPROM Read

- Step 1. Enter OCD(=ISP) mode.
- Step 2. Set ENBDM bit of BCR.
- Step 3. Enable debug and Request debug mode.
- Step 4. Read data from Data EEPROM.

#### 15.4.2.2 Enable program mode

- Step 1. Enter OCD(=ISP) mode.<sup>1</sup>
- Step 2. Set ENBDM bit of BCR.
- Step 3. Enable debug and Request debug mode.
- Step 4. Enter program/erase mode sequence.<sup>2</sup>

- (1) Write 0xA5 to FEDR.
- (2) Write 0x5A to FEDR.

<sup>1</sup> Refer to how to enter ISP mode..

<sup>2</sup> Command sequence to activate data EEPROM write/erase mode. It is composed of sequentially writing to data register(FEDR)

#### 15.4.2.3 EEPROM write mode

- Step 1. Enable program mode.
- Step 2. Reset page buffer. FEMR: 0100\_0001 FECR:0000\_0010
- Step 3. Select page buffer. FEMR:0100\_1001
- Step 4. Write data to page buffer.(Address automatically increases by twin.)
- Step 5. Set write mode. FEMR:0110\_0001
- Step 6. Set page address. FEARH:FEARM:FEARL=20'hx\_xxxx
- Step 7. Set FETCR.
- Step 8. Start program. FECR:0000\_1011
- Step 9. Insert one NOP operation
- Step 10. Read FESR until PEVBSY is 1.
- Step 11. Repeat step2 to step 8 until all pages are written.

#### 15.4.2.4 EEPROM page erase mode

- Step 1. Enable program mode.
- Step 2. Reset page buffer. FEMR: 0100\_0001 FECR:0000\_0010
- Step 3. Select page buffer. FEMR:0100\_1001
- Step 4. Write 'h00 to page buffer. (Data value is not important.)
- Step 5. Set erase mode. FEMR:0101\_0001
- Step 6. Set page address. FEARH:FEARM:FEARL=20'hx\_xxxx
- Step 7. Set FETCR.
- Step 8. Start erase. FECR:0000\_1011
- Step 9. Insert one NOP operation
- Step 10. Read FESR until PEVBSY is 1.
- Step 11. Repeat step2 to step 8 until all pages are erased.

#### 15.4.2.5 EEPROM bulk erase mode

- Step 1. Enable program mode.
- Step 2. Reset page buffer. FEMR: 0100\_0001 FECR:0000\_0010
- Step 3. Select page buffer. FEMR:0100\_1001
- Step 4. Write 'h00 to page buffer. (Data value is not important.)
- Step 5. Set erase mode. FEMR:0101\_0001.
- Step 6. Set FETCR

Step 7. Start bulk erase. FECR:0100\_1011

Step 8. Insert one NOP operation

Step 9. Read FESR until PEVBSY is 1.

#### 15.4.2.6 Data EEPROM program verify mode

Step 1. Enable program mode.

Step 2. Set program verify mode. FEMR:0110\_0011

Step 3. Read data from Flash.

#### 15.4.2.7 Data EEPROM erase verify mode

Step 1. Enable program mode.

Step 2. Set erase verify mode. FEMR:0101\_0011

Step 3. Read data from Flash.

#### 15.4.2.8 Data EEPROM page buffer read

Step 1. Enable program mode.

Step 2. Select page buffer. FEMR:0100\_1001

Step 3. Read data from Flash.

### 15.4.3 Summary of Flash and Data EEPROM Program/Erase Mode

Table 15-3 Operation Mode

Operation mode		Description
F L A S H	Flash read	Read cell by byte.
	Flash write	Write cell by bytes or page.
	Flash page erase	Erase cell by page.
	Flash bulk erase	Erase the whole cells.
	Flash program verify	Read cell in verify mode after programming.
	Flash erase verify	Read cell in verify mode after erase.
	Flash page buffer load	Load data to page buffer.
E E P R O M	Data EEPROM read	Read cell by byte.
	Data EEPROM write	Write cell by bytes or page.
	Data EEPROM page erase	Erase cell by page.
	Data EEPROM bulk erase	Erase the whole cells.
	Data EEPROM program verify	Read cell in verify mode after programming.
	Data EEPROM erase verify	Read cell in verify mode after erase.
	Data EEPROM page buffer load	Load data to page buffer.



## 15.5 Parallel Mode

### 15.5.1 Overview

Parallel program mode transfers address and data by byte. 3-byte address can be entered by one from the least significant byte of address. If only LSB is changed, only one byte can be transferred. And if the second byte is changed, the first and second byte can be transferred. Upper 4-bit of the most significant byte selects memory to be accessed. Table 15-3 shows memory type. Address auto-increment is supported when read or write data without address

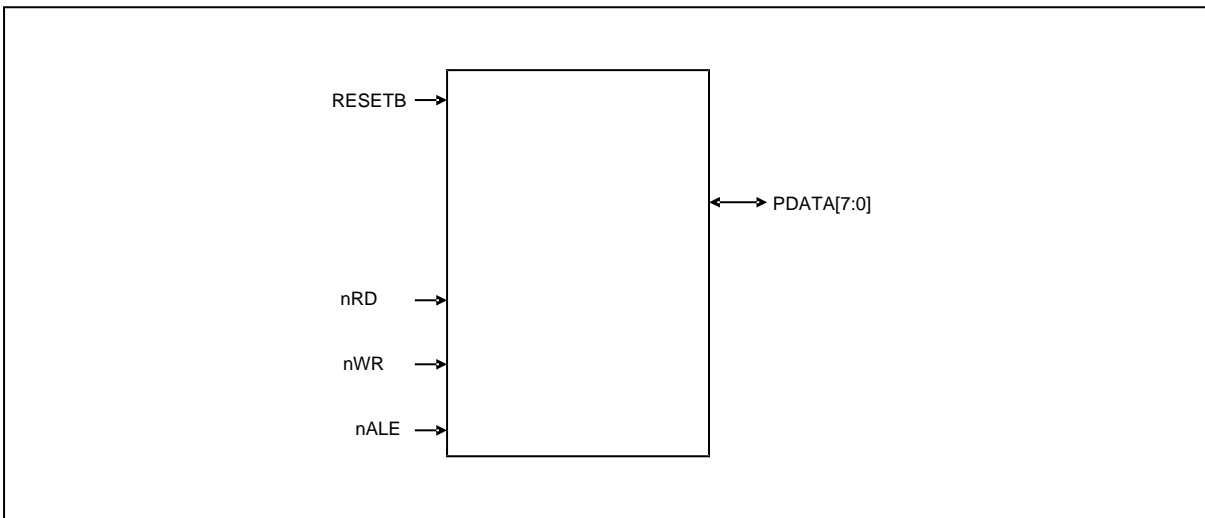

Figure 15.7 Pin diagram for parallel programming

Table 15-4 The selection of memory type by ADDRH[7:4]

ADDRH[7:4]				Memory Type
0	0	0	0	Program Memory
0	0	0	1	External Memory
0	0	1	0	SFR

### 15.5.2 Parallel Mode instruction format

Instruction	Signal	Instruction Sequence											
n-byte data read with 3-byte address	nALE	L	L	L	L	L	L	L	L	L	L	L	L
	nWR	L	H	L	H	L	H	H	H	H	H	H	H
	nRD	H	H	H	H	H	H	L	H	L	H	L	H
	PDATA	ADDRL		ADDRM		ADDRH		DATA0		DATA1		--- DATA <sub>n</sub>	
n-byte data write with 3-byte address	nALE	L	L	L	L	L	L	L	L	L	L	L	L
	nWR	L	H	L	H	L	H	L	H	L	H	L	H

	nRD	H	H	H	H	H	H	H	H	H	H	H	H	H	H
	PDATA	ADDRL		ADDRM		ADDRH		DATA0		DATA1		---		DATAn	
n-byte data read with 2-byte address	nALE	L		L		H		H		H		H		H	
	nWR	L	H	L	H	H	H	H	H	H	H	H	H	H	H
	nRD	H	H	H	H	L	H	L	H	L	H	L	H	L	H
	PDATA	ADDRL		ADDRM		DATA0		DATA1		DATA2		---		DATAn	
n-byte data write with 2-byte address	nALE	L		L		H		H		H		H		H	
	nWR	L	H	L	H	L	H	L	H	L	H	L	H	L	H
	nRD	H	H	H	H	H	H	H	H	H	H	H	H	H	H
	PDATA	ADDRL		ADDRM		DATA0		DATA1		DATA2		---		DATAn	
n-byte data read with 1-byte address	nALE	L		H		H		H		H		H		H	
	nWR	L	H	H	H	L	H	L	H	L	H	L	H	L	H
	nRD	H	H	L	H	H	H	H	H	H	H	H	H	H	H
	PDATA	ADDRL		DATA0		DATA1		DATA2		DATA3		---		DATAn	
n-byte data write with 1-byte address	nALE	L		H		H		H		H		H		H	
	nWR	L	H	L	H	L	H	L	H	L	H	L	H	L	H
	nRD	H	H	H	H	H	H	H	H	H	H	H	H	H	H
	PDATA	ADDRL		DATA0		DATA1		DATA2		DATA3		---		DATAn	

15.5.3 Parallel Mode timing diagram

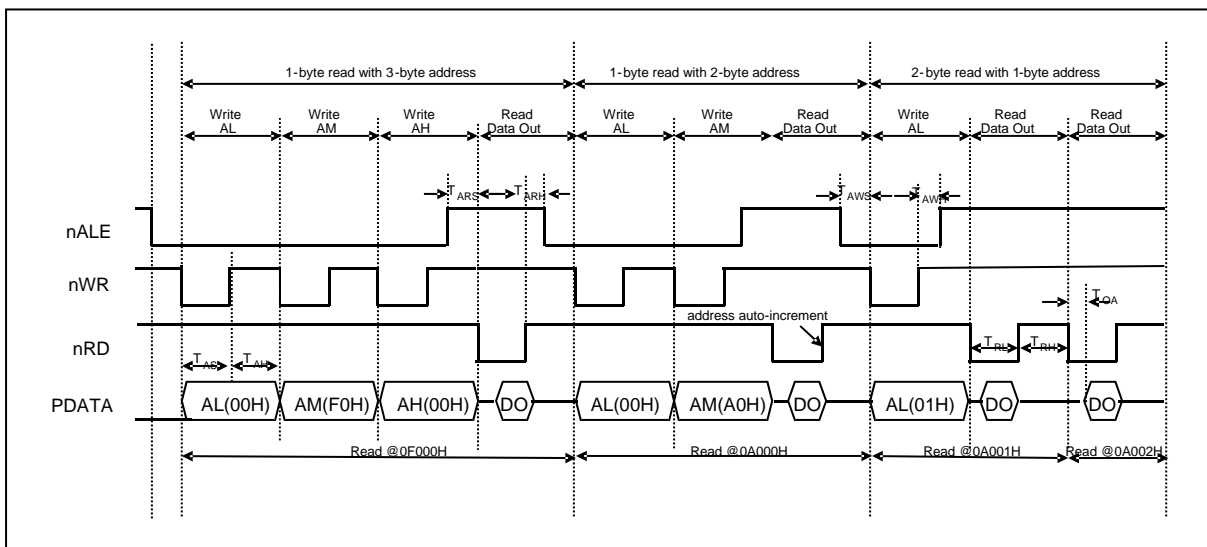

Figure 15.8 Parallel Byte Read Timing of Program Memory

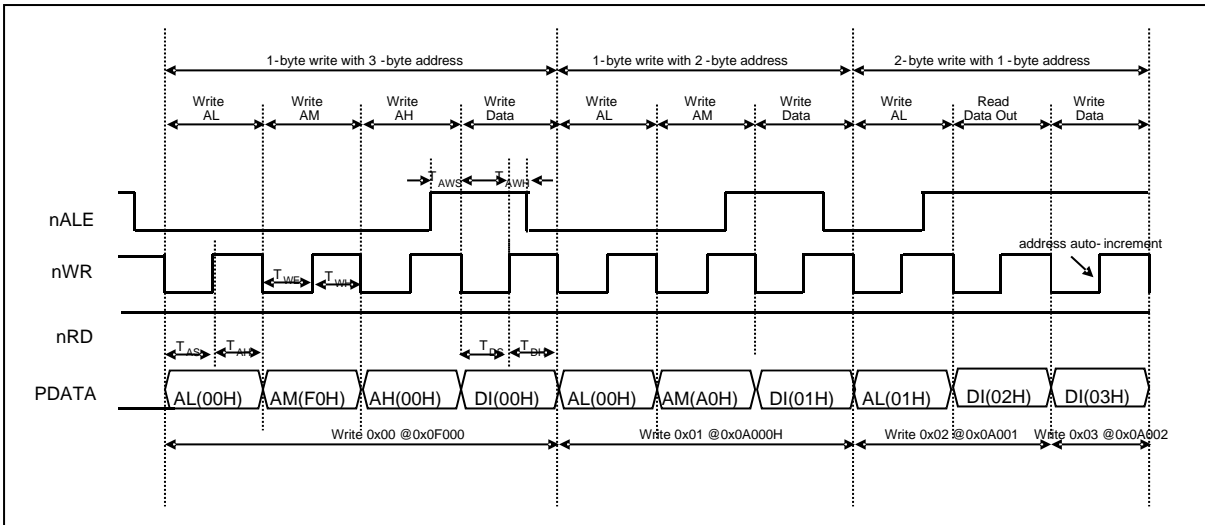

Figure 15.9 Parallel Byte Write Timing of Program Memory

### 15.6 Mode entrance method of ISP and byte-parallel mode

#### 15.6.1 Mode entrance method for ISP

TARGET MODE	DSDA	DSCL	DSDA
OCD(ISP)	'hC	'hC	'hC

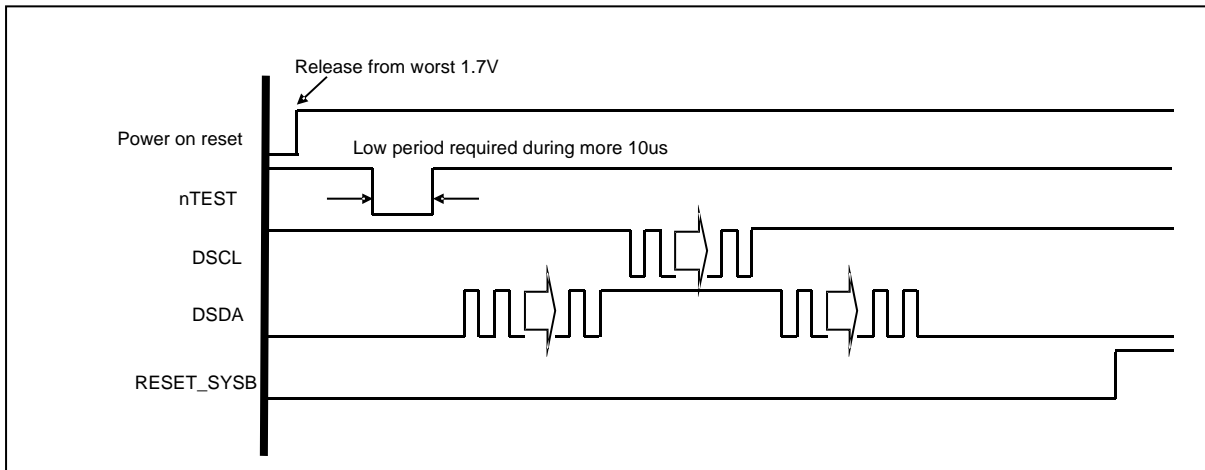

Figure 15.10 ISP mode

#### 15.6.2 Mode entrance of Byte-parallel

TARGET MODE	P0[3:0]	P0[3:0]	P0[3:0]
Byte-Parallel Mode	4'h5	4'hA	4'h5

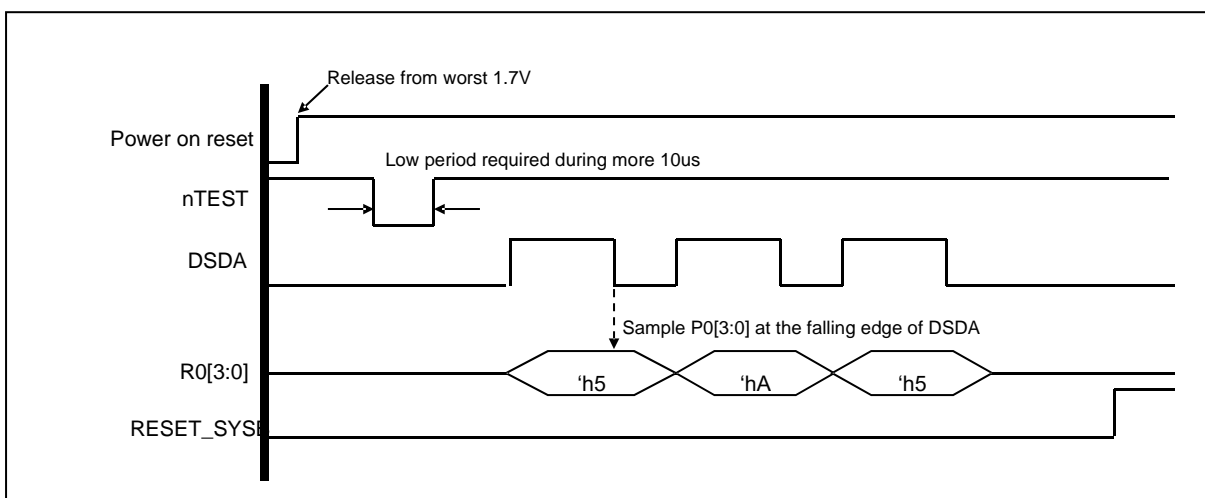

Figure 15.11 Byte-parallel mode

## 15.7 Security

MC95FG0128A provides two Lock bits which can be left un-programmed (“0”) or can be programmed (“1”) to obtain the additional features listed in Table 15-5. The Lock bit can only be erased to “0” with the bulk erase command and a value of more than 0x80 at FETCR.

**Table 15-5 Security policy using lock-bits**

LOCK MODE		USER MODE												ISP/PMODE															
		FLASH				DATA EEPROM				OTP				FLASH				DATA EEPROM				OTP							
LOC KE	LOC KF	R	W	PE	BE	R	W	PE	BE	R	W	PE	BE	R	W	PE	BE	R	W	PE	BE	R	W	PE	BE				
0	0	O	X	X	X	O	O	O	O	X	X	X	X	O	O	O	O	O	O	O	O	O	O	O	O	O	O	O	O
0	1	O	X	X	X	O	O	O	O	X	X	X	X	X	X	X	O	O	O	O	O	O	O	O	O	O	X	X	O
1	0	O	X	X	X	O	O	O	O	X	X	X	X	O	◇	◇	◇	X	X	X	O	O	◇	◇	◇	◇	◇	◇	◇
1	1	O	X	X	X	O	O	O	O	X	X	X	X	X	X	X	◇	X	X	X	O	O	X	X	◇	◇	◇	◇	◇

- LOCKF: Lock bit of Flash memory
- LOCKE: Lock bit of data EEPROM
- R: Read
- W: Write
- PE: Page erase
- BE: Bulk Erase
- O: Operation is possible.
- X: Operation is impossible.
- ◇: When LOCKE is programmed, each operation can be done after data EEPROM is erased with the bulk erase command.

## 16. Configure option

### 16.1 Configure option Control Register

FUSE\_CONF (Pseudo-Configure Data) : 2F5DH

7	6	5	4	3	2	1	0
-	-	SXINEN	XINENA	-	OCDSEL	LOCKE	LOCKF
R	R	R	R	R	R	R	R

Initial value : 00H

<b>SXINEN</b>	Enable External Sub Oscillator
0	Sub OSC disable (default)
1	Sub OSC enable
<b>XINENA</b>	Enable External Main Oscillator
0	Main OSC disable (default)
1	Main OSC enable
<b>OCDSEL</b>	Selects noise cancelling scheme of OCD pins.
0	OCD lines are outputs of 10ns noise canceller
1	OCD lines synchronized by INTRC clock
<b>LOCKE</b>	Data Read Protection
0	LOCK Disable
1	LOCK Enable
<b>LOCKF</b>	Code Read Protection
0	LOCK Disable
1	LOCK Enable

## 17. APPENDIX

### A. Instruction Table

Instructions are either 1, 2 or 3 bytes long as listed in the 'Bytes' column below.

Each instruction takes either 1, 2 or 4 machine cycles to execute as listed in the following table. 1 machine cycle comprises 2 system clock cycles.

ARITHMETIC				
Mnemonic	Description	Bytes	Cycles	Hex code
ADD A,Rn	Add register to A	1	1	28-2F
ADD A,dir	Add direct byte to A	2	1	25
ADD A,@Ri	Add indirect memory to A	1	1	26-27
ADD A,#data	Add immediate to A	2	1	24
ADDC A,Rn	Add register to A with carry	1	1	38-3F
ADDC A,dir	Add direct byte to A with carry	2	1	35
ADDC A,@Ri	Add indirect memory to A with carry	1	1	36-37
ADDC A,#data	Add immediate to A with carry	2	1	34
SUBB A,Rn	Subtract register from A with borrow	1	1	98-9F
SUBB A,dir	Subtract direct byte from A with borrow	2	1	95
SUBB A,@Ri	Subtract indirect memory from A with borrow	1	1	96-97
SUBB A,#data	Subtract immediate from A with borrow	2	1	94
INC A	Increment A	1	1	04
INC Rn	Increment register	1	1	08-0F
INC dir	Increment direct byte	2	1	05
INC @Ri	Increment indirect memory	1	1	06-07
DEC A	Decrement A	1	1	14
DEC Rn	Decrement register	1	1	18-1F
DEC dir	Decrement direct byte	2	1	15
DEC @Ri	Decrement indirect memory	1	1	16-17
INC DPTR	Increment data pointer	1	2	A3
MUL AB	Multiply A by B	1	4	A4
DIV AB	Divide A by B	1	4	84
DA A	Decimal Adjust A	1	1	D4

LOGICAL				
Mnemonic	Description	Bytes	Cycles	Hex code
ANL A,Rn	AND register to A	1	1	58-5F
ANL A,dir	AND direct byte to A	2	1	55
ANL A,@Ri	AND indirect memory to A	1	1	56-57
ANL A,#data	AND immediate to A	2	1	54
ANL dir,A	AND A to direct byte	2	1	52
ANL dir,#data	AND immediate to direct byte	3	2	53
ORL A,Rn	OR register to A	1	1	48-4F
ORL A,dir	OR direct byte to A	2	1	45
ORL A,@Ri	OR indirect memory to A	1	1	46-47
ORL A,#data	OR immediate to A	2	1	44
ORL dir,A	OR A to direct byte	2	1	42
ORL dir,#data	OR immediate to direct byte	3	2	43
XRL A,Rn	Exclusive-OR register to A	1	1	68-6F

XRL A,dir	Exclusive-OR direct byte to A	2	1	65
XRL A, @Ri	Exclusive-OR indirect memory to A	1	1	66-67
XRL A,#data	Exclusive-OR immediate to A	2	1	64
XRL dir,A	Exclusive-OR A to direct byte	2	1	62
XRL dir,#data	Exclusive-OR immediate to direct byte	3	2	63
CLR A	Clear A	1	1	E4
CPL A	Complement A	1	1	F4
SWAP A	Swap Nibbles of A	1	1	C4
RL A	Rotate A left	1	1	23
RLC A	Rotate A left through carry	1	1	33
RR A	Rotate A right	1	1	03
RRC A	Rotate A right through carry	1	1	13

DATA TRANSFER				
Mnemonic	Description	Bytes	Cycles	Hex code
MOV A,Rn	Move register to A	1	1	E8-EF
MOV A,dir	Move direct byte to A	2	1	E5
MOV A,@Ri	Move indirect memory to A	1	1	E6-E7
MOV A,#data	Move immediate to A	2	1	74
MOV Rn,A	Move A to register	1	1	F8-FF
MOV Rn,dir	Move direct byte to register	2	2	A8-AF
MOV Rn,#data	Move immediate to register	2	1	78-7F
MOV dir,A	Move A to direct byte	2	1	F5
MOV dir,Rn	Move register to direct byte	2	2	88-8F
MOV dir,dir	Move direct byte to direct byte	3	2	85
MOV dir,@Ri	Move indirect memory to direct byte	2	2	86-87
MOV dir,#data	Move immediate to direct byte	3	2	75
MOV @Ri,A	Move A to indirect memory	1	1	F6-F7
MOV @Ri,dir	Move direct byte to indirect memory	2	2	A6-A7
MOV @Ri,#data	Move immediate to indirect memory	2	1	76-77
MOV DPTR,#data	Move immediate to data pointer	3	2	90
MOVC A,@A+DPTR	Move code byte relative DPTR to A	1	2	93
MOVC A,@A+PC	Move code byte relative PC to A	1	2	83
MOVX A,@Ri	Move external data(A8) to A	1	2	E2-E3
MOVX A,@DPTR	Move external data(A16) to A	1	2	E0
MOVX @Ri,A	Move A to external data(A8)	1	2	F2-F3
MOVX @DPTR,A	Move A to external data(A16)	1	2	F0
PUSH dir	Push direct byte onto stack	2	2	C0
POP dir	Pop direct byte from stack	2	2	D0
XCH A,Rn	Exchange A and register	1	1	C8-CF
XCH A,dir	Exchange A and direct byte	2	1	C5
XCH A,@Ri	Exchange A and indirect memory	1	1	C6-C7
XCHD A,@Ri	Exchange A and indirect memory nibble	1	1	D6-D7

BOOLEAN				
Mnemonic	Description	Bytes	Cycles	Hex code
CLR C	Clear carry	1	1	C3
CLR bit	Clear direct bit	2	1	C2
SETB C	Set carry	1	1	D3
SETB bit	Set direct bit	2	1	D2



CPL C	Complement carry	1	1	B3
CPL bit	Complement direct bit	2	1	B2
ANL C,bit	AND direct bit to carry	2	2	82
ANL C,/bit	AND direct bit inverse to carry	2	2	B0
ORL C,bit	OR direct bit to carry	2	2	72
ORL C,/bit	OR direct bit inverse to carry	2	2	A0
MOV C,bit	Move direct bit to carry	2	1	A2
MOV bit,C	Move carry to direct bit	2	2	92

BRANCHING				
Mnemonic	Description	Bytes	Cycles	Hex code
ACALL addr 11	Absolute jump to subroutine	2	2	11→F1
LCALL addr 16	Long jump to subroutine	3	2	12
RET	Return from subroutine	1	2	22
RETI	Return from interrupt	1	2	32
AJMP addr 11	Absolute jump unconditional	2	2	01→E1
LJMP addr 16	Long jump unconditional	3	2	02
SJMP rel	Short jump (relative address)	2	2	80
JC rel	Jump on carry = 1	2	2	40
JNC rel	Jump on carry = 0	2	2	50
JB bit,rel	Jump on direct bit = 1	3	2	20
JNB bit,rel	Jump on direct bit = 0	3	2	30
JBC bit,rel	Jump on direct bit = 1 and clear	3	2	10
JMP @A+DPTR	Jump indirect relative DPTR	1	2	73
JZ rel	Jump on accumulator = 0	2	2	60
JNZ rel	Jump on accumulator ≠ 0	2	2	70
CJNE A,dir,rel	Compare A,direct jne relative	3	2	B5
CJNE A,#d,rel	Compare A,immediate jne relative	3	2	B4
CJNE Rn,#d,rel	Compare register, immediate jne relative	3	2	B8-BF
CJNE @Ri,#d,rel	Compare indirect, immediate jne relative	3	2	B6-B7
DJNZ Rn,rel	Decrement register, jnz relative	2	2	D8-DF
DJNZ dir,rel	Decrement direct byte, jnz relative	3	2	D5

MISCELLANEOUS				
Mnemonic	Description	Bytes	Cycles	Hex code
NOP	No operation	1	1	00

ADDITIONAL INSTRUCTIONS (selected through EO[7:4])				
Mnemonic	Description	Bytes	Cycles	Hex code
MOVC @(DPTR++),A	M8051W/M8051EW-specific instruction supporting software download into program memory	1	2	A5
TRAP	Software break command	1	1	A5

In the above table, an entry such as E8-EF indicates a continuous block of hex op-codes used for 8 different registers, the register numbers of which are defined by the lowest three bits of the corresponding code. Non-continuous blocks of codes, shown as 11→F1 (for example), are used for absolute jumps and calls, with the top 3 bits of the code being used to store the top three bits of the destination address.

The CJNE instructions use the abbreviation #d for immediate data; other instructions use #data.

## B. Package relation

	MC95FG0128A	MC95FG8128A	MC95FG6128A
Pin count	100	80	64
Max I/O	86	66	52
Difference (removed functions on standard MC95FG0128A)	-	←	P6[4:7] (EC4,5)*
	-	←	P7[0:7] (PCI7)
	-	P8[2:7]	P8[0:7]
	-	P9[0:7] (usart3)	P9[0:7] (usart3)
	-	PA[0:5]	PA[0:5]

Notice \*) Timer4,5 can not only use External clock input source mode.

## C. LFP example circuit

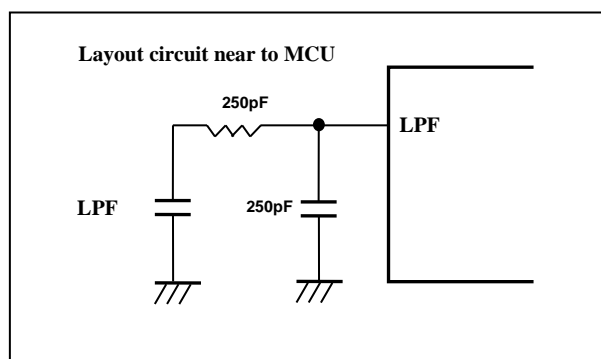

## D. Instructions on how to use the input port.

- Error occur status
  - Using compare jump instructions with input port, it could cause error due to the timing conflict inside the MCU.
  - Compare jump Instructions which cause potential error used with input port condition:
    - JB bit, rel ; jump on direct bit=1
    - JNB bit, rel ; jump on direct bit=0
    - JBC bit, rel ; jump on direct bit=1 and clear
    - CJNE A, dir, rel ; compare A, direct jne relative
    - DJNZ dir, rel ; decrement direct byte, jnz relative
- It is only related with Input port. Internal parameters, SFRs and output bit ports don't cause any error by using compare jump instructions.
- If input signal is fixed, there is no error in using compare jump instructions.
- Error status example

```
while(1){
  if (P00==1){ P10=1; }
  else { P10=0; }
  P11^=1;
}
```

```
zzz: JNB 080.0, xxx ; it possible to be error
      SETB 088.0
      SJMP yyy
xxx: CLR 088.0
yyy: MOV C,088.1
      CPL C
      MOV 088.1,C
      SJMP zzz
```

```
unsigned char ret_bit_err(void)
{
  return !P00;
}
```

```
MOV R7, #000
JB 080.0, xxx ; it possible to be error
MOV R7, #001
xxx: RET
```

- Preventative measures (2 cases)
  - Do not use input bit port for bit operation but for byte operation. Using byte operation instead of bit operation will not cause any error in using compare jump instructions for input port.

```
while(1){
  if ((P0&0x01)==0x01){ P10=1; }
  else { P10=0; }
  P11^=1;
}
```

```
zzz: MOV A, 080 ; read as byte
      JNB 0E0.0, xxx ; compare
      SETB 088.0
      SJMP yyy
xxx: CLR 088.0
yyy: MOV C,088.1
      CPL C
      MOV 088.1,C
      SJMP zzz
```

```
bit tt;
while(1){
  tt=P00;
  if (tt==0){ P10=1;}
  else { P10=0;}
  P11^=1;
}
```

```
zzz: MOV C,080.0 ; input port use internal parameter
      MOV 020.0, C ; move
      JB 020.0, xxx ; compare
      SETB 088.0
      SJMP yyy
xxx: CLR 088.0
yyy: MOV C,088.1
      CPL C
      MOV 088.1,C
      SJMP zzz
```

- If you use input bit port for compare jump instruction, you have to copy the input port as internal parameter or carry bit and then use compare jump instruction.